



RSF Elektronik

RELIABLE. SOPHISTICATED. FLEXIBLE.

Incremental Linear Encoders

Enclosed Models





RSF Elektronik Ges.m.b.H.



RSF Elektronik was founded 1973 in St. Georgen near Salzburg, Austria.

From the beginning, the objective was to develop and produce Linear and Rotary Encoders and Digital Readouts. Our products were well accepted in the market, and after some years, the company employed more than 100 people.

Due to growth, it was then necessary for RSF Elektronik to move into larger facilities. The company moved in 1978 to our current location. Today, the largest percentage of our shipments are Incremental Linear Encoders.

To guarantee the best possible support, we have built Distribution contacts in the most important markets.

One of the main internal elements of opto-electronic measuring systems are high precision divisions on glass and/or steel carriers. Under the trade name "SENTOP", RSF Elektronik manufactures Precision Graduations in thin layer technology.

Our quality, performance and environment management comply with DIN EN ISO 9001 and DIN EN ISO 14001 standards.

Table of contents

	Page
General description	Design and operation4/5
	Output signals.....6
	Subdividing Electronics, connecting cables.....7
	Shield connections8
	Environmental sealing8
Overview	Nomenclature9
	Selection guide 10 - 13
Technical data, Dimensions, Mounting tolerances Mounting possibilities	MSA 17014/15
	MSA 670, MSA 69016/17
	MSA 671, MSA 69118/19
	MSA 67220/21
	MSA 68022/23
	MSA 370, MSA 39024/25
	MSA 371, MSA 39126/27
	MSA 37228/29
	MSA 373, MSA 374, MSA 37530/31
	Positioning of the switching magnets at MSA 690, MSA 691, MSA 390, MSA 391, MSA 373, MSA 374, MSA 37532
	Pin-outs, Switch signals at MSA 690, MSA 691, MSA 390, MSA 391, MSA 373, MSA 374, MSA 37533
	MSA 65034/35
	MSA 65136/37
	MSA 35038/39
	MSA 35240/41
Accessories	Subdividing Electronics ZE42
	InterFaceCard IFC 430R43
	Male and female connectors, pin-outs.....44
	Air Pressure Unit DA30045
Other RSF-Products	Open Linear Encoder46
	Digital Readouts47
Branch Offices	Addresses.....48

Design and operation

RSF manufactures Linear Encoders in enclosed and open versions. The enclosed models are easy to install with large mounting tolerances. They are also best suited for harsh environments. The sealing lips on the extrusion keep out coolants and contamination.

The non-contact open measuring systems are for high displacement velocities and high accuracies, commonly used in clean environments.

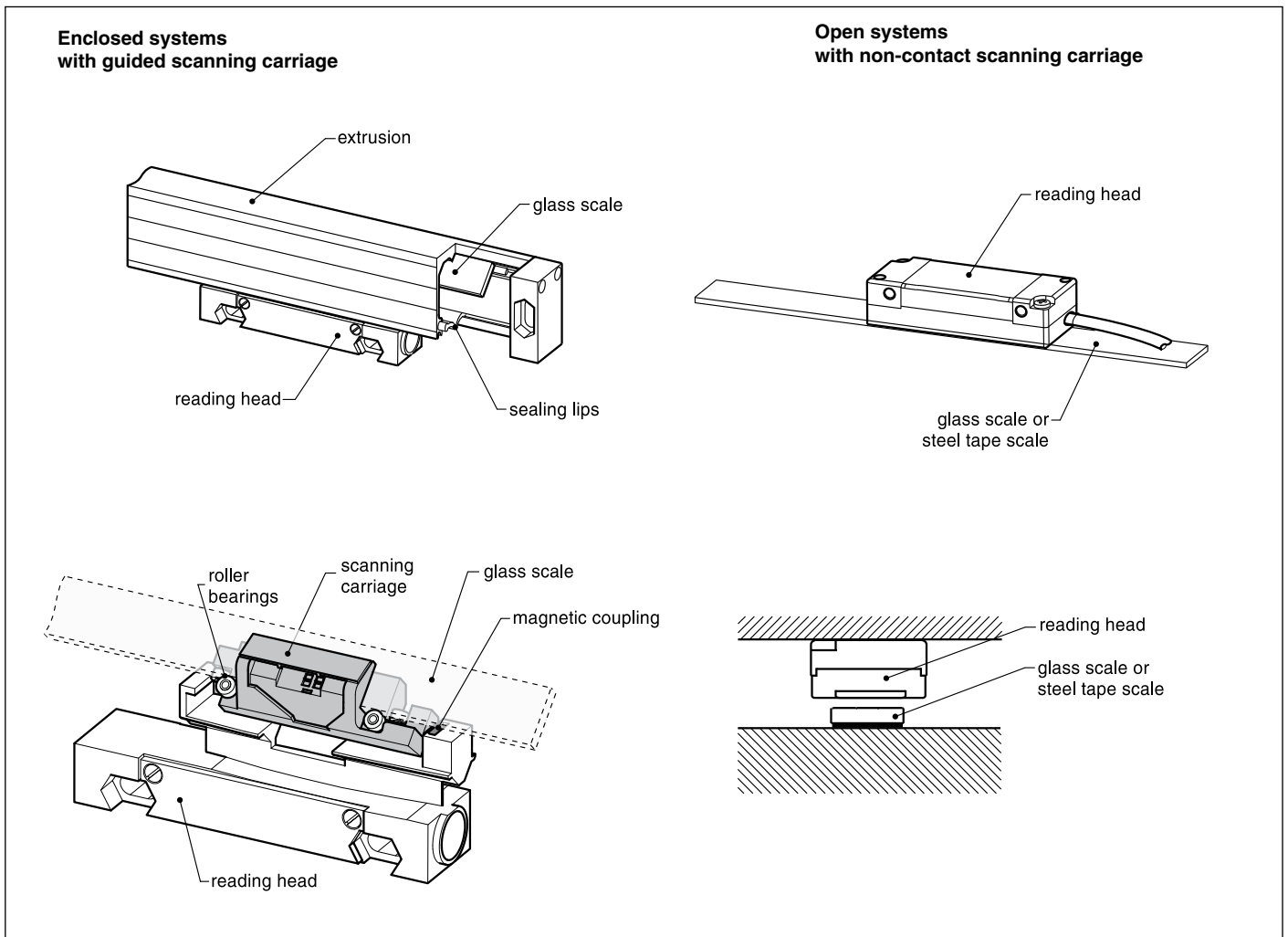

Enclosed Linear Encoders have a roller bearing, self-guided scanning carriage. The scanning carriage is spring loaded to track properly within the encoder head mounting tolerance range. A set of rare earth magnets couple the scanning carriage to the mounting base of the encoder head.

This magnetic coupling compensates allowable mounting tolerances and machine guide non-parallelism. Non-contact open encoders rely on the air gap between the encoder head and scale to be uniform over the measuring range. The flatness of the mounting surface and the parallelism of the machine guideway is important.

The scale graduation pattern has a high accuracy grating.
 Scales can be produced on metal tape or spars, or glass substrates.
 One cycle (period) of grating pitch, is defined as one chrome line and one corresponding line space, each with the same width.
 The total width of one chrome line and one line space is called grating pitch.
 A second track adjacent to the graduation pattern, contains the Reference Mark(s).
 There are standard Reference Mark locations, or they can be specified upon request.
 Multiple Reference Marks must be separated by $n \times 50$ mm distances.

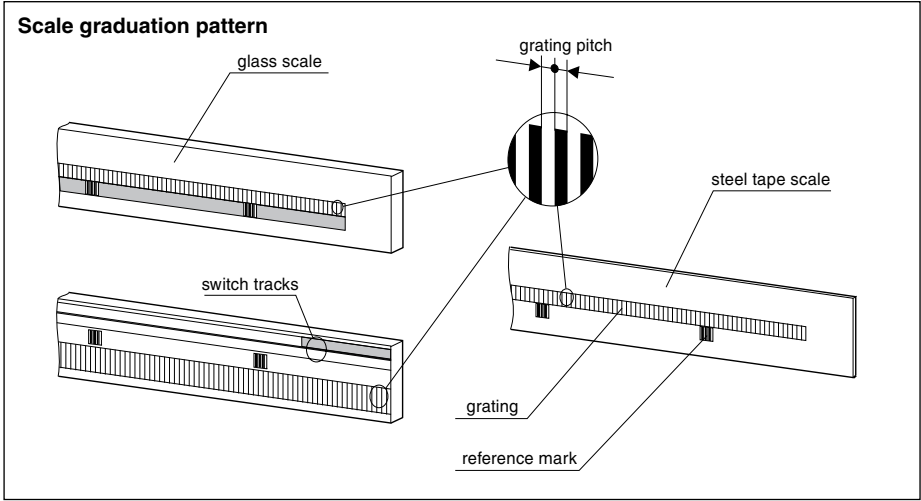

Linear Encoders with the suffix "K" in the model type have distance coded Reference Marks. The absolute position is available after a measured move of a maximum of 20 mm .

Cause of the optical scanning version a accurate Reference Mark is warranted.

When there is relative movement between the encoder head and the linear scale, LED light is modulated by the scale grating pitch and converted into electrical signals by the photo-elements. Solid state LEDs and silicon photo-elements are used for high reliability and durability.

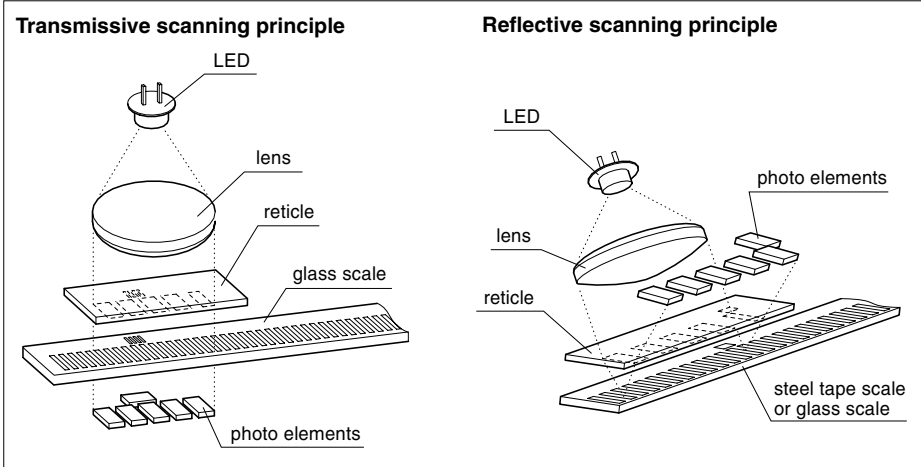

The scale consists of a glass carrier and reflection-type phase grating. The scanning reticle acts as transmission phase grating.

The light beam, produced by an LED and collimated by a lens, is deflected by prisms and the phase grating of the reticle in different directions. After reflection and diffraction at the scale grating, the different beams, depending on the change of position phase shifted, interfere after passing the reticle again, thus producing 2 by 90° shifted, sinusoidal measuring signals. Using this interferential measuring principle, one signal period equals half of the scale grating pitch.

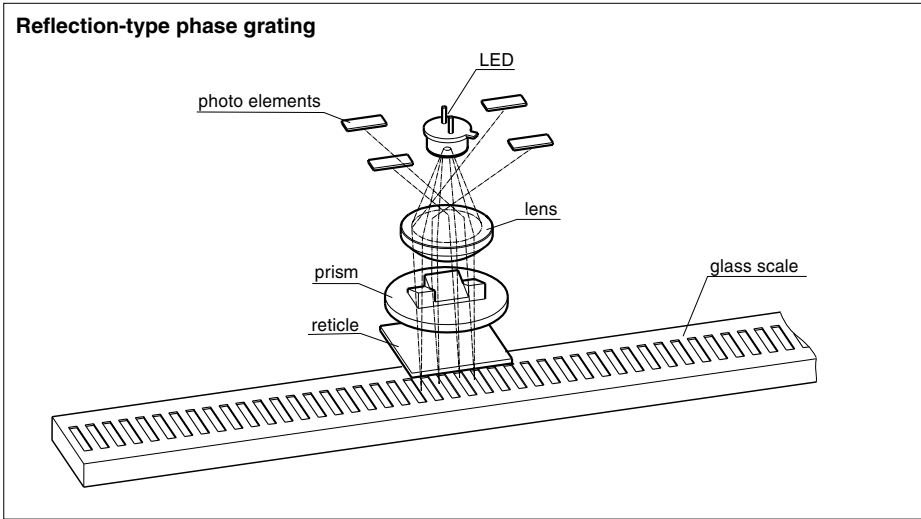

Output signals

Sinusoidal voltage signals

There are two sinusoidal voltage signals (A1 and A2) and one Reference Index (with inverted signals).

Reference voltage of the output signals:

$V+ / 2$ (approx. 2.5 V)

Track signals (differential voltage

A1 to A1 resp. A2 to A2):

Phaseshift $90^\circ \pm 10^\circ$ el.

electrical offset $\pm 10\%$ of the signal amplitude

Signal amplitude 0.6 Vpp to 1.2 Vpp

typ. 1 Vpp with terminating impedance

$Z_0 = 120 \Omega$

Reference Mark

(differential voltage RI to RI):

El. position typically 135°

(referenced to A1)

El. width typically 270°

Useable component 0.2 up to 0.85 V,

typical 0.5 V with terminating

impedance $Z_0 = 120 \Omega$

Advantage: High traversing speed with long cable lengths possible.

These signals are suitable for the connection to appropriate CNC and/or Feedback Systems.

Sinusoidal micro-current signals

There are two sinusoidal micro-current signals (0° and 90°) and one Reference Index (with inverted signals).

Output signals 0° and 90° :

Phaseshift $90^\circ \pm 10^\circ$ el.

electrical offset $\pm 10\%$ of the signal amplitude

Signal amplitude with a load of $1 \text{ k}\Omega$:

7 to $16 \mu\text{App}$ ($11.5 \mu\text{App}$ typical)

Output signal Reference Mark (RI):

El. Position typical 135° (referenced to 0°)

El. width typical 270°

2 to $8 \mu\text{A}$, (typical $5 \mu\text{A}$)

These signals can be input to External Subdividing Electronics or NC Controls with built-in Subdividing Electronics.

Square wave signals

With a Schmitt-Trigger (for times 1) or interpolation electronics (for times 5, -10, -20, -25, -50 or -100) the photoelement output signals are converted into two square wave signals that have a phase shift of 90° . Output signals either can be single ended or Line Driver differential (RS 422).

For measuring systems with single ended output signals the max. cable length is 10 m, including extension cable.

One measuring step reflects the measuring distance between two edges of the square wave signals. The controls/DRO's must be able to detect each edge of the square wave signals.

The minimum edge separation a_{min} is listed in the technical data and refers to a measurement at the output of the interpolator (inside the scanning head).

Propagation-time differences in the Line Driver, the cable and the Line Receiver reduce the edge separation.

Propagation-time differences:

Line Driver: max. 10 ns

Cable: 0.2 ns per meter

Line Receiver: max. 10 ns referred to the recommended Line Receiver circuit

To prevent counting errors, the controls/DRO's must be able to process the resulting edge separation.

Example:

$a_{\text{min}} = 100 \text{ ns}$, 10 m cable

The control/DRO must be able to detect $100 \text{ ns} - 10 \text{ ns} - 10 \times 0.2 \text{ ns} - 10 \text{ ns} = 78 \text{ ns}$

Advantage:

- Noise immune signals
- No further subdividing electronics necessary

Drawing in "positive counting direction"

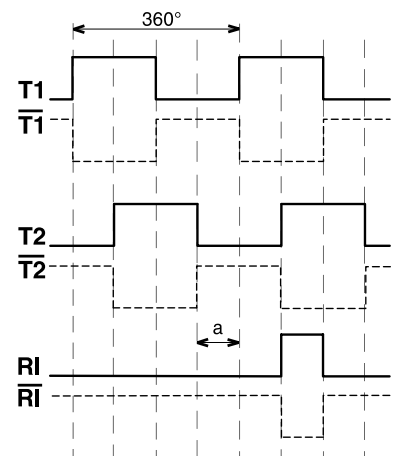
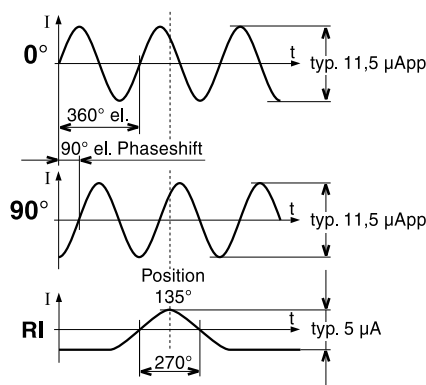
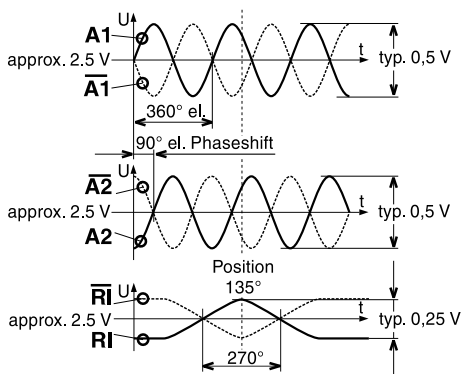

Recommended Line Receiver circuit

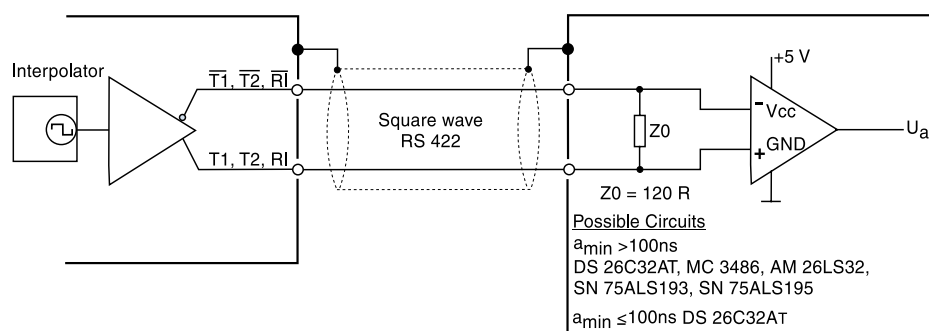

Positive counting direction orientation

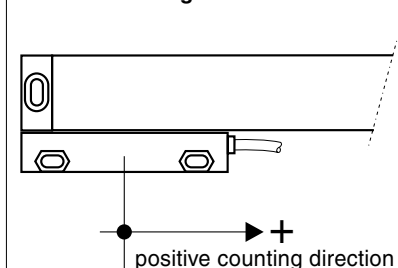

Subdividing Electronics Connecting cables

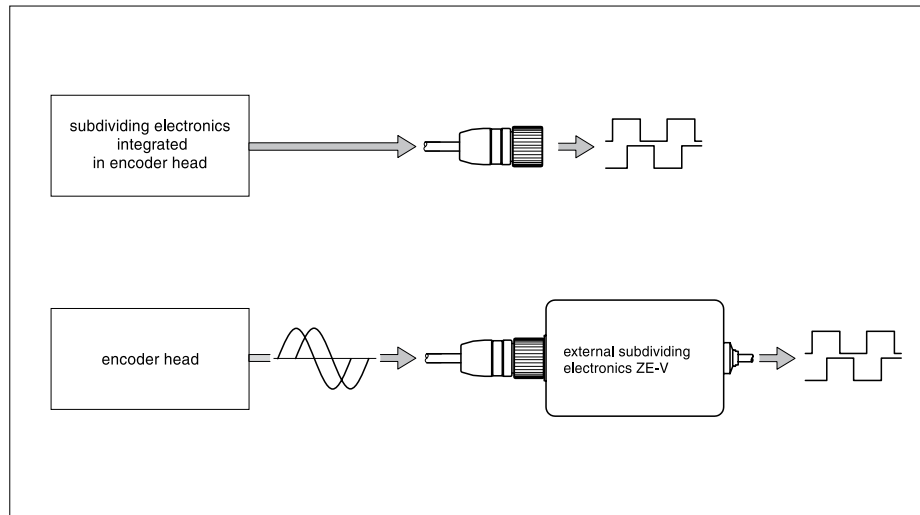

Signal interpolation is available in two versions.

- Subdividing Electronics integrated in the encoder head offer the advantage of reduced parts and labor, lower hardware cost, and it eliminates the need for space to mount an external subdividing electronic unit.
- External Subdividing Electronics require sinusoidal micro-current input signals (ZE-Vx) or sinusoidal voltage signal (ZE-Sx)

Both versions can output differential Line Driver RS 422 square wave signals.

Output signals resp. constructional features	Cable Ø mm	Shield	Minimum Bend radius	
			Fixed mount	Continuous bending *
Sinusoidal micro-current signals and sinusoidal voltage signals	5.7	double	45 mm	85 mm
	4.4	double, high flex	35 mm	70 mm
	3.9	double, ultra high flex	30 mm	60 mm
Square wave signals	5.7	single	45 mm	85 mm
MSA 65x and MSA 35x	4.8	single, with metal braiding	25 mm	50 mm
	4.3		25 mm	45 mm

Encoder heads have cables designed for the specific signal outputs. Standard cable length is 3 m. The cable jacket is a special thermoplastic, resistant to commercial coolants and lubricants. Cables should be protected with a metallic armor if exposed to a harsh environment like "hot metal chips". The cables can be used in the following temperature ranges:
Fixed cable mounting: -20°C to +70°C
Continuous flexing: -5°C to +70°C

* Cycle of bending typical 50 million

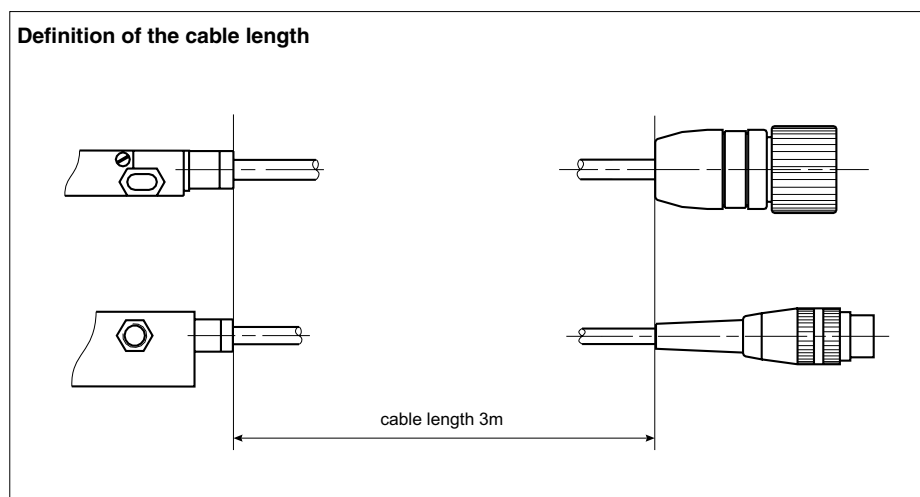

Shield connections

Sinusoidal micro-current signals Sinusoidal voltage signals

The inner shield connector pin must be connected to protective ground with 0V

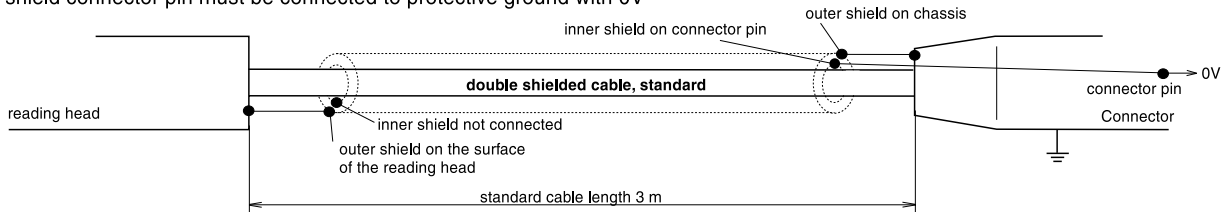

Square wave signals

The inner shield connector pin must be connected to protective ground with 0V

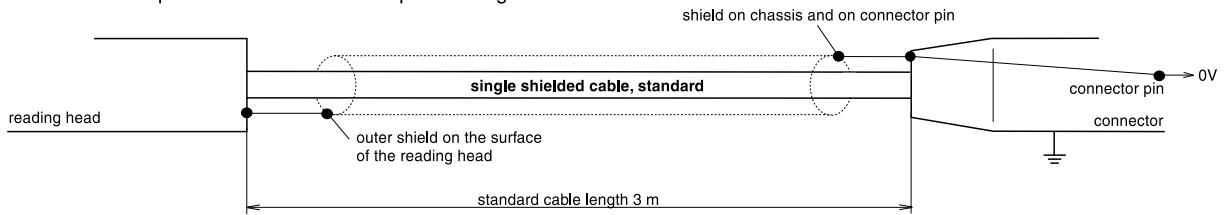

Square wave signals

The inner shield connector pin must be connected to protective ground with 0V

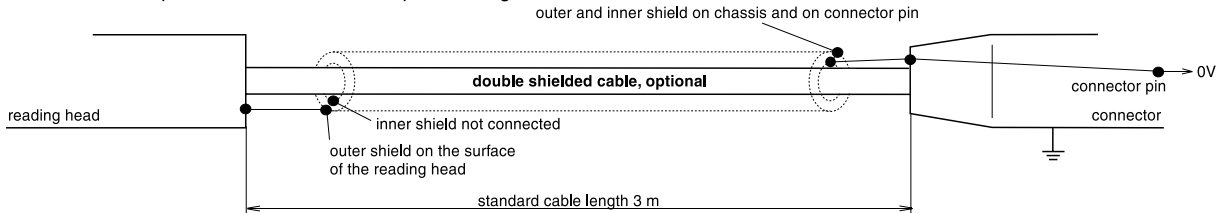

Environmental sealing

Environmental sealing

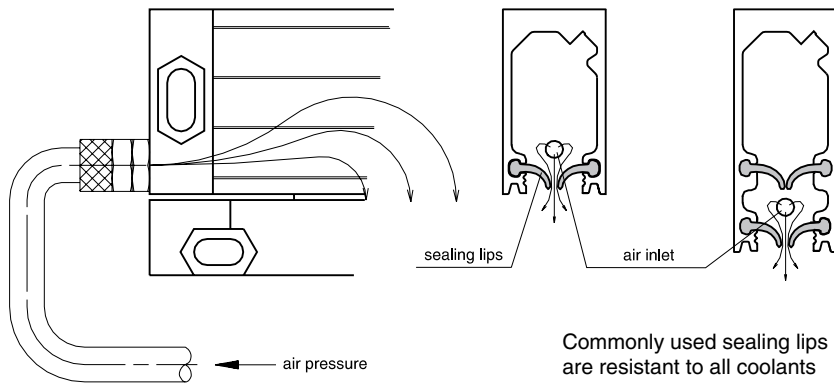

For applications where the Linear Encoders are used in harsh environments (e.g. oil and coolants), there are two methods of extra protection beyond the enclosed unit's standard set of sealing lips.

1. An air inlet can be provided for filtered air to be input into the scale spar. A limiting flow restrictor helps set the optimum overpressure airflow inside the scale spar to further prevent oil and coolants from entering the seal.
2. Scale spars with two sets of sealing lips are available. The area between the two sets of sealing lips can also be pressurized to achieve the best possible environmental sealing.

Air pressure unit DA300

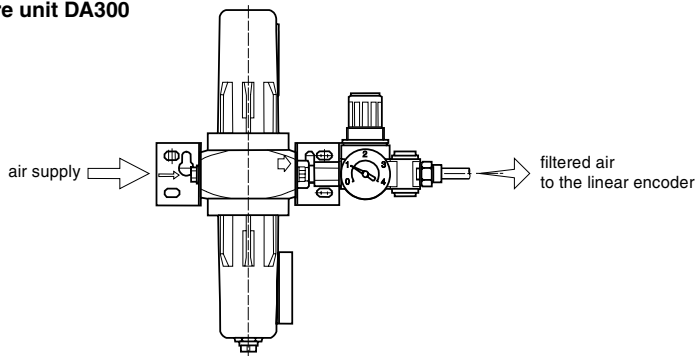

When filtered air is not available, the **RSF Air Pressure Unit DA300**, or an equivalent, should be used. Pressure is adjustable. To avoid measuring errors due to thermal differences, it is absolutely necessary to provide pressurized air that has the same temperature as the machine tool. The DA300 requires standard compressed air at the input.

Nomenclature

Encoder Name

XXXXXX.XX-X XX

Encoder Type (design features)

XXX**XXX**.XX-X XX

Output signals and integrated Subdividing

XXXXXX.**XX**-X XX

- 0 = sinusoidal voltage signals 1 Vpp
- 1 = sinusoidal micro-current signals 7 to 16 μ A
- 2 = square wave signals, times 1
- 3 = square wave signals, times 2
- 4 = square wave signals, times 20

- 5 = square wave signals, times 25
- 6 = square wave signals, times 5
- 7 = square wave signals, times 10
- 8 = square wave signals, times 50
- 9 = square wave signals, times 100

Grating pitch

XXXXXX.X**X**-X XX

- | | | | | |
|----------------|-----------------|-------------------|--------------------|----------------|
| 0 = 8 μ m | 5 = 100 μ m | A = 6,35 μ m | F = 101,60 μ m | M = 150 L/Inch |
| 1 = 10 μ m | 6 = 200 μ m | B = 10,16 μ m | G = 25,40 μ m | N = 360 L/Inch |
| 2 = 16 μ m | 7 = 400 μ m | C = 12,70 μ m | H = 35 μ m | R = 720 L/Inch |
| 3 = 20 μ m | 8 = 50 μ m | D = 20,32 μ m | K = 2160 L/Inch | |
| 4 = 40 μ m | | E = 50,80 μ m | L = 1200 L/Inch | |

Version of the switch signal

(only for Linear Encoder with switch magnets)

XXXXXX.XX-**X** XX

- 0 = without switch signal
- 1 = TTL output (active high)
- 2 = open collector output (active high impedance)
- 3 = TTL output (active low)
- 4 = open collector output (active low)

Possible options

- K = distance coded Reference marks
- P = input for compressed air

XXXXXX.XX-X **XX**

For example:

MSA690 .63-1 P

small cross-section, mounting holes on the extrusion ends, with switch magnets

square wave output signals, integrated Subdividing times 5

grating pitch 20 μ m

switch signal with TTL output (active high)

input for compressed air

Overview, Selection guide

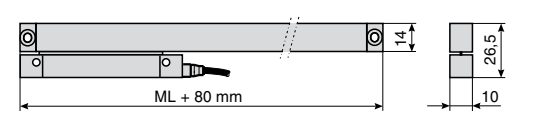
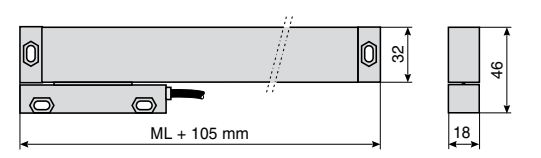
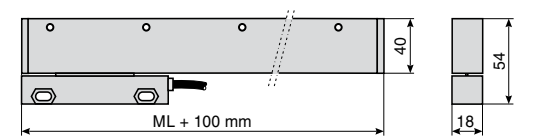
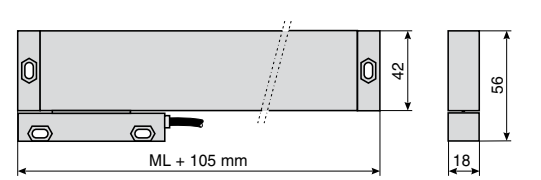
Design features	Basic dimensions ML = measuring length	Scale type	Page
<ul style="list-style-type: none"> extremely small cross section guided by ball bearings distance coded Reference Marks (K) max. measuring length 520 mm enclosed version mounting holes on the extrusion ends resolution from 5 µm up to 0,1 µm 		MSA 170	14-15
<ul style="list-style-type: none"> distance coded Reference Marks (K) max. measuring length 2240 mm small cross-section enclosed version mounting holes on the extrusion ends resolution from 10 µm up to 0,1 µm free positionable switching magnets for special functions (MSA 690) 		MSA 670 MSA 690	16-17
<ul style="list-style-type: none"> distance coded Reference Marks (K) max. measuring length 2240 mm small cross-section enclosed version mounting holes on top of the extrusion improves vibration rating resolution from 10 µm up to 0,1 µm free positionable switching magnets for special functions (MSA 691) 		MSA 671 MSA 691	18-19
<ul style="list-style-type: none"> two sets of sealing lips for additional contamination protection distance coded Reference Marks (K) max. measuring length 2240 mm small cross-section enclosed version mounting holes on the extrusion ends resolution from 10 µm up to 0,1 µm 		MSA 672	20-21

Design features**Basic dimensions**
ML = measuring length**Scale type****Page**

- **with optimized thermal performance**
- distance coded Reference Marks (K)
- max. measuring length 1240 mm
- small cross-section
- enclosed version
- mounting holes on the extrusion ends
- resolution from 5 μm up to 0,1 μm

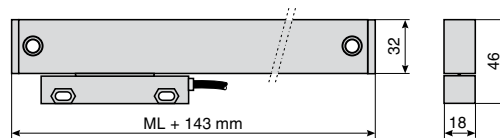
**MSA 680**

22-23

- distance coded Reference Marks (K)
- max. measuring length 3040 mm
- rigid mounting
- large cross-section
- enclosed version
- mounting holes on the extrusion ends and with mounting supports
- resolution from 10 μm up to 0,1 μm
- **individual choosing of the reference mark (MSA390)**
- **free positionable switching magnets for special functions (MSA 390)**

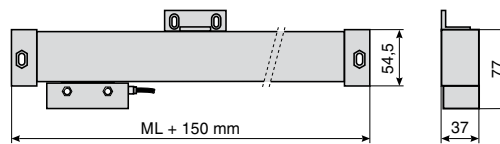
**MSA 370**

24-25

MSA 390

- distance coded Reference Marks (K)
- max. measuring length 3040 mm
- rigid mounting
- mounting holes on top of the extrusion improves vibration rating
- large cross-section
- enclosed version
- resolution from 10 μm up to 0,1 μm
- **individual choosing of the reference mark (MSA 391)**
- **free positionable switching magnets for special functions (MSA 391)**

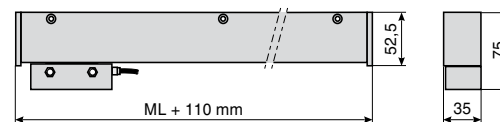
**MSA 371**

26-27

MSA 391

Overview, Selection guide

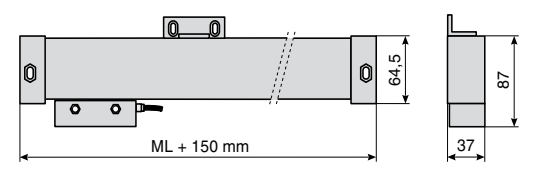
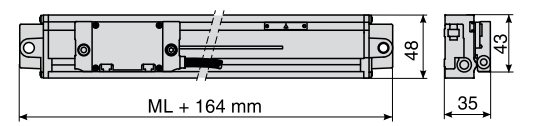
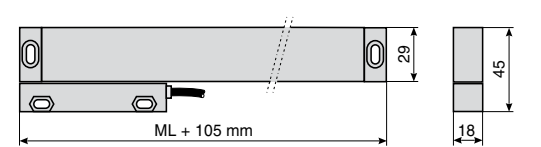
Design features	Basic dimensions ML = measuring length	Scale type	Page
<ul style="list-style-type: none"> • two sets of sealing lips for additional contamination protection • distance coded Reference Marks (K) • max. measuring length 3040 mm • rigid mounting • large cross-section • enclosed version • mounting holes on the extrusion ends and with mounting supports • resolution from 10 µm up to 0,1 µm 		MSA 372	28-29
<ul style="list-style-type: none"> • self guided Encoder • for application on presses, bending machines and hydraulic cylinders • free positionable switching magnets for special functions • integrated, protected guideway • max. measuring length 720 mm • rigid mounting • enclosed version • mounting holes on the extrusion ends • encoder head attached to machine with rod in end of head bracket • resolution: 5 µm or 0,1 µm 		MSA 373 MSA 374 MSA 375	30-31
<ul style="list-style-type: none"> • for retrofit of machine tools • high mounting tolerances • distance coded Reference Marks (K) • max. measuring length 1740 mm • small cross-section • enclosed version • mounting holes on the extrusion ends • resolution from 10 µm up to 0,5 µm 		MSA 650	34-35

Design features**Basic dimensions**
ML = measuring length**Scale type****Page**

- for retrofit of machine tools
- high mounting tolerances
- distance coded Reference Marks (K)
- max. measuring length 2240 mm
- small cross-section
- enclosed version
- mounting holes on top of the extrusion improves vibration rating
- resolution from 10 μm up to 0,5 μm

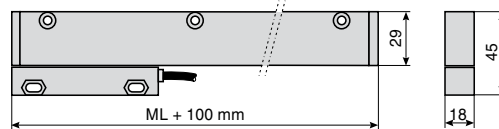
**MSA 651**

36-37

-
- for retrofit of machine tools
 - high mounting tolerances
 - distance coded Reference Marks (K)
 - max. measuring length 3040 mm
 - rigid mounting
 - large cross-section
 - enclosed version
 - mounting holes on the extrusion ends and with mounting supports
 - resolution from 10 μm up to 0,5 μm

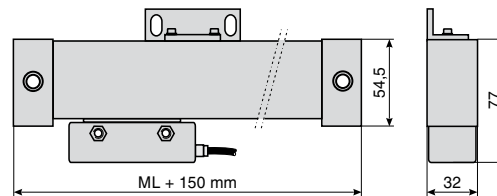
**MSA 350**

38-39

-
- for retrofit of machine tools
 - high mounting tolerances
 - with two sets of sealing lips
 - distance coded Reference Marks (K)
 - max. measuring length 3040 mm
 - rigid mounting
 - large cross-section
 - enclosed version
 - mounting holes on the extrusion ends and with mounting supports
 - resolution from 10 μm up to 0,5 μm

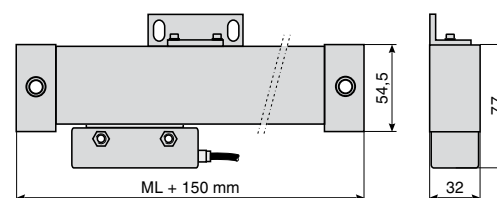
**MSA 352**

40-41

MSA 170

Scale model	System resolution	Accuracy grades*	Grating pitch* (Edge separation a_{min})	Max. velocity
• Sinusoidal voltage signals 1 V_{pp}				
MSA 170.03	depending on external subdividing	±3, ±5, μm/m	20 μm	1 m/s
• Sinusoidal micro-current signals				
MSA 170.13	depending on external subdividing	±3, ±5, μm/m	20 μm	1 m/s
• Square wave Line Driver signals with integrated Subdividing				
MSA 170.23	5 μm	±3, ±5 μm/m	20 μm	1 m/s (3.3 μs)
MSA 170.63	1 μm	±3, ±5 μm/m	20 μm	1 m/s (500 ns)
MSA 170.73	0.5 μm	±3, ±5 μm/m	20 μm	1 m/s (300 ns)
MSA 170.53	0.2 μm	±3, ±5 μm/m	20 μm	0.6 m/s (300 ns)
MSA 170.83	0.1 μm	±3, ±5 μm/m	20 μm	0.3 m/s (300 ns)

* Other accuracy grades or grating pitches (e.g. Inch) upon request

Standard measuring lengths: (mm)

50, 70, 120, 170, 220, 270, 320, 370, 420, 470, 520,

Measuring type: glass scale

Reference mark (RI): selectable

MSA 170.xx **K**

Distance coded Reference Marks (**K**): after travelling 20 mm the absolute position will be shown on the display.

MSA 170.xx

One Reference Mark in the middle of the measuring length, or 10 mm from either end of the measuring length (excluding ML 50 mm).

Option:

One Reference mark at any location, or two or more Reference Marks separated by distances of $n \times 25$ mm.

Required moving force: < 1 N

Environmental sealing DIN 40050:

IP 53 (with standard sealing lips)

IP 64 with DA300 (DA300 see page 45)

Permissible vibration: 100 m/s² (40 to 2000 Hz)

Permissible shock: 150 m/s² (8 ms)

Permissible temperature:

-20°C to +70°C (storage), 0°C to +50°C (operation)

Weight (approx.):

22 g/100 mm (scale spar) + 35 g (scanning head without cable)

Signal-outputs (optional):

**• Sinusoidal voltage signals
MSA 170.03**

Power supply:

+5V ±5%, max. 75 mA (unloaded)

Output signals:

Encoder signals: 0.6 to 1,2 V_{pp}, typical 1 V_{pp}
with terminating resistor $Z_0 = 120 \Omega$

Reference pulse:

0.2 to 0.85 V_{pp}, typical 0.4 V (useable component)
with terminating resistor $Z_0 = 120 \Omega$

Max. output frequency:

100 kHz (with 3 m cable)

**• Sinusoidal micro-current signals
MSA 170.13**

Power supply:

+5V ±5%, max. 75 mA

Output signals:

Encoder signals: 7 to 16 μA_{pp},
typical 11.5 μA_{pp} at 1 K Ω

Reference pulse: 2 to 8 μA,

typical 5 μA (useable component) at 1 K Ω

Max. output frequency:

50 kHz (with 3 m cable)

**• Square wave signals (single ended)
with integrated Subdividing Electronics**

**• Square wave signals (differential)
via Line Driver RS 422 standard
with integrated Subdividing Electronics**

MSA 170.23 = times1

MSA 170.63 = times5

MSA 170.73 = times10

MSA 170.53 = times25

MSA 170.83 = times50

Power supply:

+5 V ±5%, max. 120 mA (unloaded)

MSA 170 Dimensions - Mounting tolerances - Mounting possibilities:

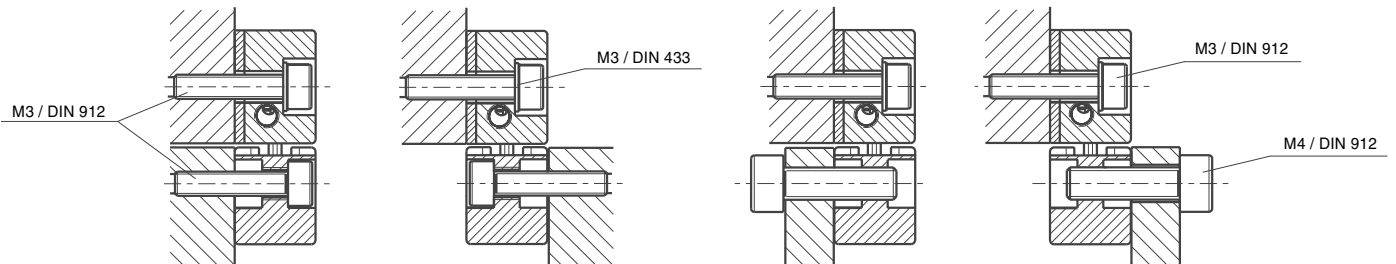
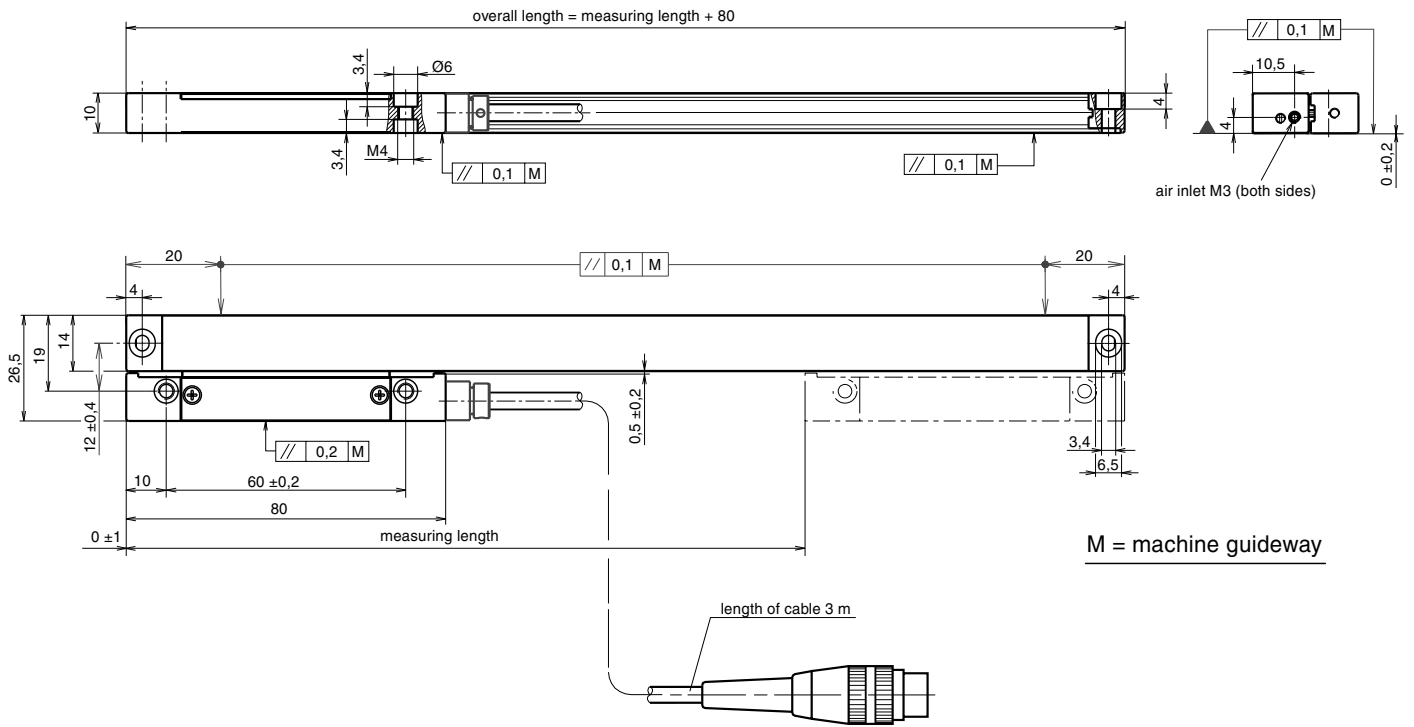
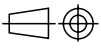

MSA 670

MSA 690 (with switch signals)

Scale model	System resolution	Accuracy grades *	Grating pitch (Edge separation a_{min}) *	Max. velocity continuous momentary	
• Sinusoidal voltage signals 1 V_{pp}					
MSA 670.03	depending on external subdividing	±3, ±5, ±10 μm/m	20 μm	1 m/s	2 m/s
MSA 670.01	depending on external subdividing	±2, ±3 μm/m	10 μm	1 m/s	1 m/s
• Sinusoidal micro-current signals					
MSA 670.13	depending on external subdividing	±3, ±5, ±10 μm/m	20 μm	1 m/s	2 m/s
MSA 670.11	depending on external subdividing	±2, ±3 μm/m	10 μm	1 m/s	1 m/s
• Square wave Line Driver signals with integrated Subdividing					
MSA 670.24	10 μm	±10 μm/m	40 μm	1 m/s (6.6 μs)	2 m/s (3.3 μs)
MSA 670.23	5 μm	±5, ±10 μm/m	20 μm	1 m/s (3.3 μs)	2 m/s (1.6 μs)
MSA 670.64	2 μm	±5 μm/m	40 μm	1 m/s (1.2 μs)	2 m/s (600 ns)
MSA 670.63	1 μm	±3, ±5 μm/m	20 μm	1 m/s (600 ns)	1 m/s (600 ns)
MSA 670.73	0.5 μm	±3, ±5 μm/m	20 μm	1 m/s (300 ns)	1 m/s (300 ns)
MSA 670.71	0.25 μm	±2, ±3, ±5 μm/m	10 μm	0.5 m/s (300 ns)	0.5 m/s (300 ns)
MSA 670.51	0.1 μm	±2, ±3, ±5 μm/m	10 μm	0.45 m/s (200 ns)	0.45 m/s (200 ns)

* Other accuracy grades or grating pitches (e.g. Inch) upon request

Standard measuring lengths: (mm)

70, 120, 170, 220, 270, 320, 370, 420, 470, 520, 620, 720, 820, 920, 1040, 1140, 1240, 1340, 1440, 1540, 1640, 1740, 1840, 2040, 2240

Measuring type: glass scale

Reference Mark (RI): selectable

MSA 670.xx K, MSA 690.xx K:

Distance coded Reference Marks (K): after travelling 20 mm the absolute position will be shown on the display.

MSA 670.xx, MSA 690.xx:

Up to a measuring length of 920 mm, one Reference Mark can either be placed in the middle of scales 1040 mm or longer, or 35 mm from either end of measuring length.

With a measuring length of 1040 mm or longer, a Reference Mark will be placed 45 mm from either end of the measured length.

Option:

One Reference Mark at any location, or two or more Reference Marks separated by distances of $n \times 50$ mm

MSA 690.xx

Free positionable switching magnets for special functions:

The position of the 2 switch points (S1 and S2) within the measured length can be selected by the customer (details on page 32 and 33)

Required moving force: with standard sealing lips < 3 N
with low drag sealing lips < 0.2 N

Environmental sealing DIN 40050: IP 53 (with standard sealing lips)
IP 64 with DA300 (DA300 see page 45)

Permissible vibration: 100 m/s² (40 to 2000 Hz), Permissible shock: 200 m/s² (8 ms)

Permissible temperature: -20°C to +70°C (storage), 0°C to +50°C (operation)

Weight (approx.): 0.8 kg/m (scale spar) + 75 g (scanning head without cable)

Signal-outputs (optional):

- Sinusoidal voltage signals
MSA 670.03
MSA 670.01

Power supply:

+5V ±5%, max. 120 mA (unloaded)

Output signals:

Encoder signals: 0.6 to 1.2 V_{pp}, typical 1 V_{pp}
with terminating resistor $Z_0 = 120 \Omega$

Reference pulse:

0.2 to 0.85 V_{pp}, typical 0.4 V (useable component)
with terminating resistor $Z_0 = 120 \Omega$

Max. output frequency:

100 kHz (with 3 m cable)

- Sinusoidal micro-current signals
MSA 670.13
MSA 670.11

Power supply:

+5V ±5%, max. 120 mA

Output signals:

Encoder signals: 7 to 16 μA_{pp},
typical 11.5 μA_{pp} at 1 KΩ

Reference pulse: 2 to 8 μA,

typical 5 μA (useable component) at 1 KΩ

Max. output frequency:

100 kHz (with 3 m cable)

- Square wave signals (single ended)
with integrated Subdividing Electronics

- Square wave signals (differential)
via Line Driver RS 422 standard
with integrated Subdividing Electronics

MSA 670.23 = times1

MSA 670.24 = times1

MSA 670.63 = times5

MSA 670.64 = times5

MSA 670.73 = times10

MSA 670.71 = times10

MSA 670.51 = times25

Power supply:

+5 V ±5%, max. 150 mA (unloaded)

MSA 670, MSA 690 Dimensions - Mounting tolerances - Mounting possibilities:

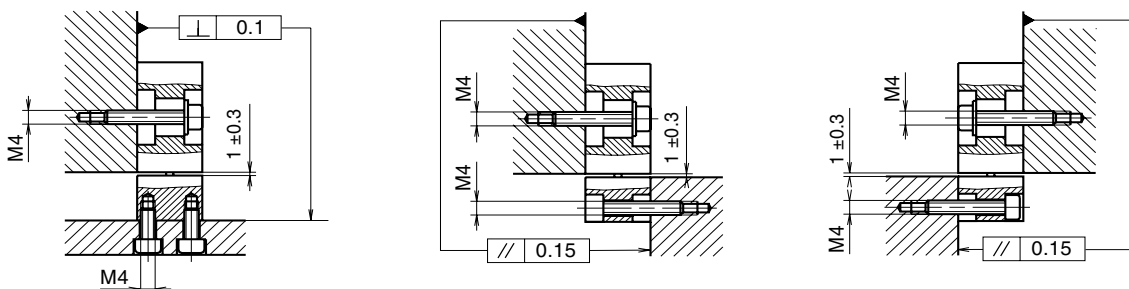
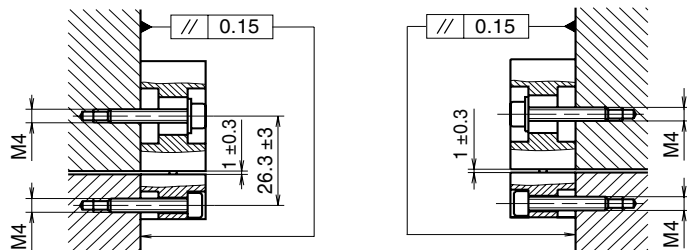
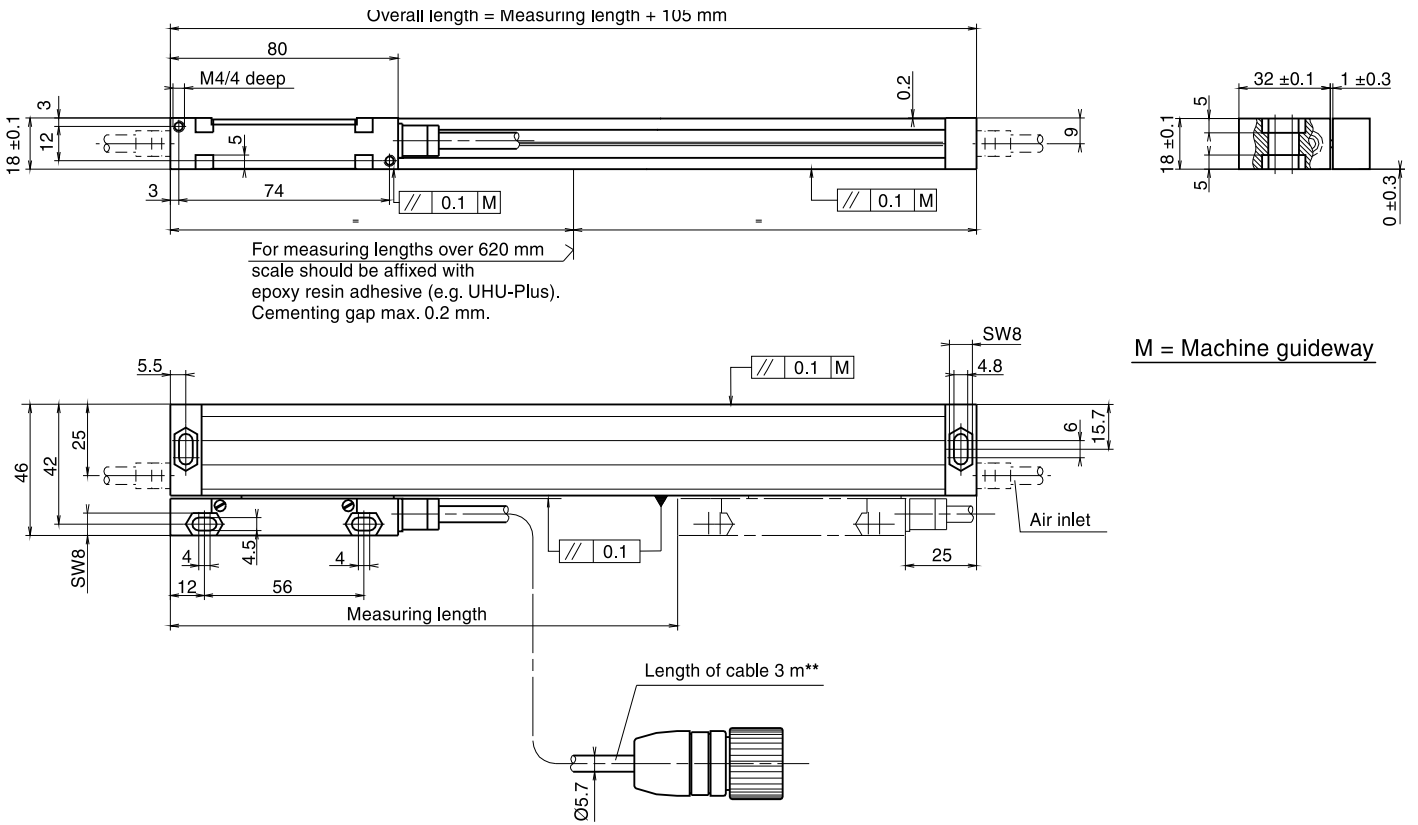
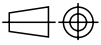

** armoured cable optional

MSA 671

MSA 691 (with switch signals)

Scale model	System resolution	Accuracy grades *	Grating pitch (Edge separation a_{min}) *	Max. velocity continuous momentary	
• Sinusoidal voltage signals 1 V_{pp}					
MSA 671.03	depending on external subdividing	$\pm 3, \pm 5, \pm 10 \mu\text{m/m}$	20 μm	1 m/s	2 m/s
MSA 671.01	depending on external subdividing	$\pm 2, \pm 3 \mu\text{m/m}$	10 μm	1 m/s	1 m/s
• Sinusoidal micro-current signals					
MSA 671.13	depending on external subdividing	$\pm 3, \pm 5, \pm 10 \mu\text{m/m}$	20 μm	1 m/s	2 m/s
MSA 671.11	depending on external subdividing	$\pm 2, \pm 3 \mu\text{m/m}$	10 μm	1 m/s	1 m/s
• Square wave Line Driver signals with integrated Subdividing					
MSA 671.24	10 μm	$\pm 10 \mu\text{m/m}$	40 μm	1 m/s (6.6 μs)	2 m/s (3.3 μs)
MSA 671.23	5 μm	$\pm 5, \pm 10 \mu\text{m/m}$	20 μm	1 m/s (3.3 μs)	2 m/s (1.6 μs)
MSA 671.64	2 μm	$\pm 5 \mu\text{m/m}$	40 μm	1 m/s (1.2 μs)	2 m/s (600 ns)
MSA 671.63	1 μm	$\pm 3, \pm 5 \mu\text{m/m}$	20 μm	1 m/s (600 ns)	1 m/s (600 ns)
MSA 671.73	0.5 μm	$\pm 3, \pm 5 \mu\text{m/m}$	20 μm	1 m/s (300 ns)	1 m/s (300 ns)
MSA 671.71	0.25 μm	$\pm 2, \pm 3, \pm 5 \mu\text{m/m}$	10 μm	0.5 m/s (300 ns)	0.5 m/s (300 ns)
MSA 671.51	0.1 μm	$\pm 2, \pm 3, \pm 5 \mu\text{m/m}$	10 μm	0.45 m/s (200 ns)	0.45 m/s (200 ns)

* Other accuracy grades or grating pitches (e.g. Inch) upon request

Standard measuring lengths: (mm)

70, 120, 170, 220, 270, 320, 370, 420, 470, 520, 620, 720, 820, 920, 1040, 1140, 1240, 1340, 1440, 1540, 1640, 1740, 1840, 2040, 2240

Measuring type: glass scale

Reference Mark (RI): selectable

MSA 671.xx K, MSA 691.xx K:

Distance coded Reference Marks (K): after travelling 20 mm the absolute position will be shown on the display.

MSA 671.xx, MSA 691.xx:

Up to a measuring length of 920 mm, one Reference Mark can either be placed in the middle of scales 1040 mm or longer, or 35 mm from either end of measuring length. With a measuring length of 1040 mm or longer, a Reference Mark will be placed 45 mm from either end of the measured length.

Option:

One Reference Mark at any location, or two or more Reference Marks separated by distances of $n \times 50$ mm

MSA 691.xx

Free positionable switching magnets for special functions:

The position of the 2 switch points (S1 and S2) within the measured length can be selected by the customer (details on page 32 and 33)

Required moving force: with standard sealing lips < 3 N
with low drag sealing lips < 0.2 N

Environmental sealing DIN 40050: IP 53 (with standard sealing lips)
IP 64 with DA300 (DA300 see page 45)

Permissible vibration: 150 m/s² (40 to 2000 Hz), Permissible shock: 300 m/s² (8 ms)

Permissible temperature: -20°C to +70°C (storage), 0°C to +50°C (operation)

Weight (approx.): 0.8 kg/m (scale spar) + 75 g (scanning head without cable)

Signal-outputs (optional):

- Sinusoidal voltage signals
MSA 671.03
MSA 671.01

Power supply:

+5V $\pm 5\%$, max. 120 mA (unloaded)

Output signals:

Encoder signals: 0.6 to 1.2 V_{pp}, typical 1 V_{pp}
with terminating resistor $Z_0 = 120 \Omega$

Reference pulse:

0.2 to 0.85 V_{pp}, typical 0.4 V (useable component)
with terminating resistor $Z_0 = 120 \Omega$

Max. output frequency:

100 kHz (with 3 m cable)

- Sinusoidal micro-current signals
MSA 671.13
MSA 671.11

Power supply:

+5V $\pm 5\%$, max. 120 mA

Output signals:

Encoder signals: 7 to 16 μA_{pp} ,
typical 11.5 μA_{pp} at 1 K Ω

Reference pulse: 2 to 8 μA ,

typical 5 μA (useable component) at 1 K Ω

Max. output frequency:

100 kHz (with 3 m cable)

- Square wave signals (single ended)
with integrated Subdividing Electronics

- Square wave signals (differential)
via Line Driver RS 422 standard
with integrated Subdividing Electronics

MSA 671.23 = times1

MSA 671.24 = times1

MSA 671.63 = times5

MSA 671.64 = times5

MSA 671.73 = times10

MSA 671.71 = times10

MSA 671.51 = times25

Power supply:

+5 V $\pm 5\%$, max. 150 mA (unloaded)

MSA 671, MSA 691 Dimensions - Mounting tolerances - Mounting possibilities:

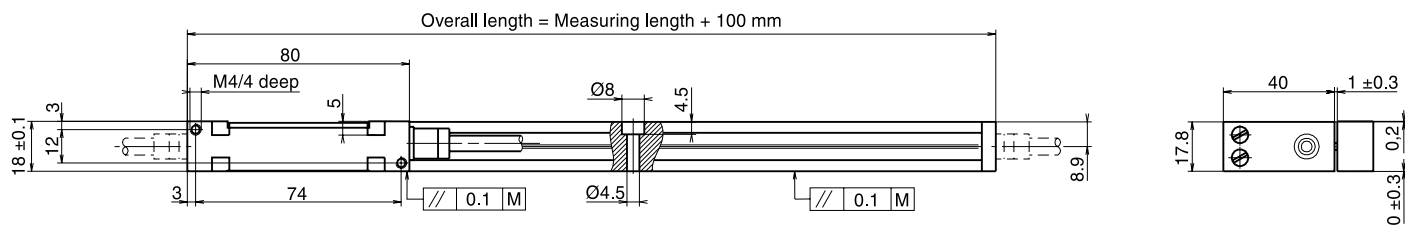
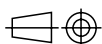

M = machine guideway

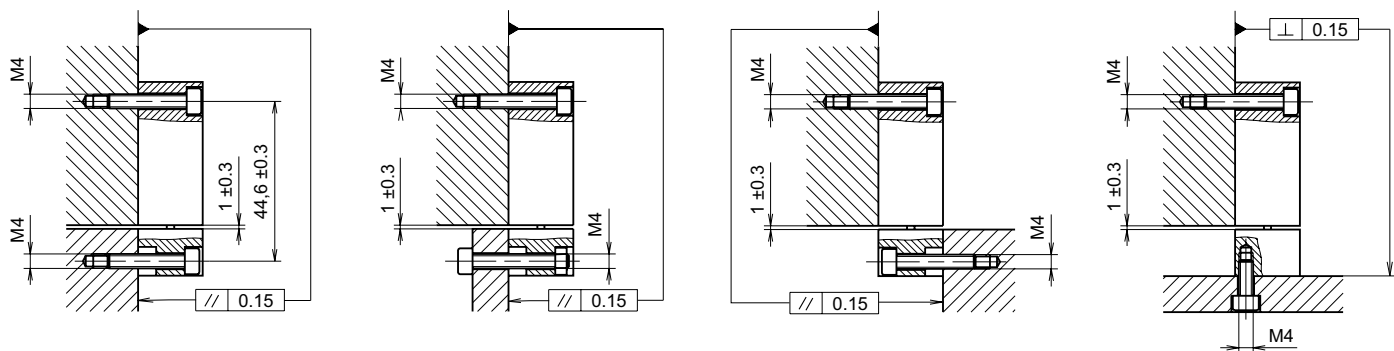
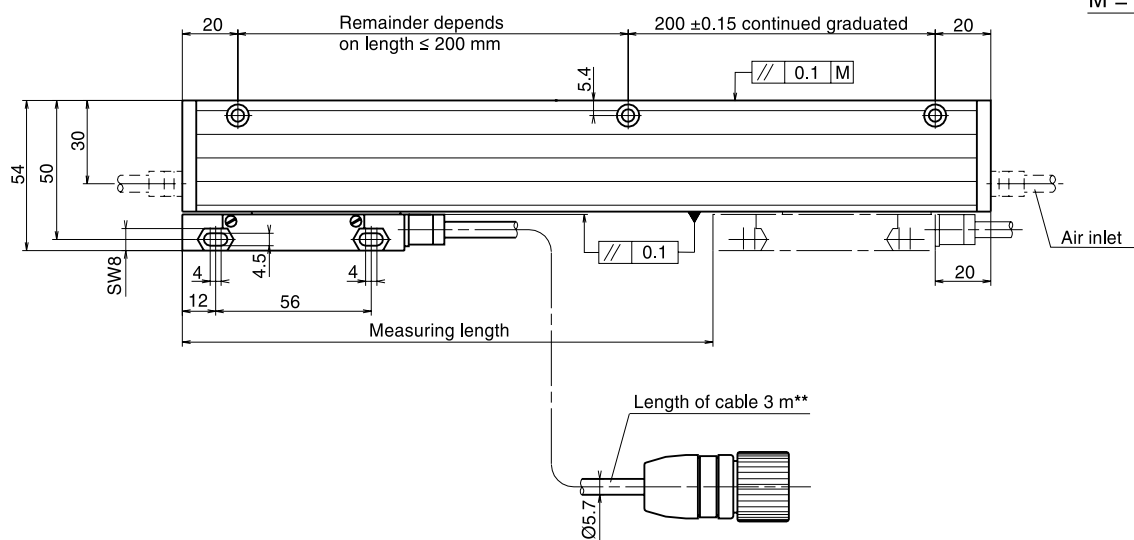

** armoured cable optional

MSA 672

Scale model	System resolution	Accuracy grades *	Grating pitch * (Edge separation a_{min})	Max. velocity continuous momentary	
• Sinusoidal voltage signals 1 V_{pp}					
MSA 672.03	depending on external subdividing	±3, ±5, ±10 μm/m	20 μm	1 m/s	2 m/s
MSA 672.01	depending on external subdividing	±2, ±3 μm/m	10 μm	1 m/s	1 m/s
• Sinusoidal micro-current signals					
MSA 672.13	depending on external subdividing	±3, ±5, ±10 μm/m	20 μm	1 m/s	2 m/s
MSA 672.11	depending on external subdividing	±2, ±3 μm/m	10 μm	1 m/s	1 m/s
• Square wave Line Driver signals with integrated Subdividing					
MSA 672.24	10 μm	±10 μm/m	40 μm	1 m/s (6.6 μs)	2 m/s (3.3 μs)
MSA 672.23	5 μm	±5, ±10 μm/m	20 μm	1 m/s (3.3 μs)	2 m/s (1.6 μs)
MSA 672.64	2 μm	±5 μm/m	40 μm	1 m/s (1.2 μs)	2 m/s (600 ns)
MSA 672.63	1 μm	±3, ±5 μm/m	20 μm	1 m/s (600 ns)	1 m/s (600 ns)
MSA 672.73	0.5 μm	±3, ±5 μm/m	20 μm	1 m/s (300 ns)	1 m/s (300 ns)
MSA 672.71	0.25 μm	±2, ±3, ±5 μm/m	10 μm	0.5 m/s (300 ns)	0.5 m/s (300 ns)
MSA 672.51	0.1 μm	±2, ±3, ±5 μm/m	10 μm	0.45 m/s (200 ns)	0.45 m/s (200 ns)

* Other accuracy grades or grating pitches (e.g. Inch) upon request

Standard measuring lengths: (mm)

70, 120, 170, 220, 270, 320, 370, 420, 470, 520, 620, 720, 820, 920, 1040, 1140, 1240, 1340, 1440, 1540, 1640, 1740, 1840, 2040, 2240

Measuring type: glass scale

Reference Mark (RI): selectable

MSA 672.xx **K**:

Distance coded Reference Marks (**K**): after travelling 20 mm the absolute position will be shown on the display.

MSA 672.xx:

Up to a measuring length of 920 mm, one Reference Mark can either be placed in the middle of scales 1040 mm or longer, or 35 mm from either end of measuring length. With a measuring length of 1040 mm or longer, a Reference Mark will be placed 45 mm from either end of the measured length.

Option:

One Reference Mark at any location, or two or more Reference Marks separated by distances of $n \times 50$ mm

Required moving force:

< 6 N (two sets of sealing lips)

Environmental sealing DIN 40050:

IP 54 (two sets of sealing lips)

IP 64 with DA300 (DA300 see page 45)

Permissible vibration: 150 m/s² (40 to 2000 Hz)

Permissible shock: 300 m/s² (8 ms)

Permissible temperature:

-20°C to +70°C (storage), 0°C to +50°C (operation)

Weight (approx.):

0.8 kg/m (scale spar) + 80 g (scanning head without cable)

Signal-outputs (optional):

• Sinusoidal voltage signals

MSA 672.03

MSA 672.01

Power supply:

+5V ±5%, max. 120 mA (unloaded)

Output signals:

Encoder signals: 0.6 to 1.2 V_{pp}, typical 1 V_{pp} with terminating resistor $Z_0 = 120 \Omega$

Reference pulse:

0.2 to 0.85 V_{pp}, typical 0.4 V (useable component) with terminating resistor $Z_0 = 120 \Omega$

Max. output frequency:

100 kHz (with 3 m cable)

• Sinusoidal micro-current signals

MSA 672.13

MSA 672.11

Power supply:

+5 V ±5%, max. 120 mA

Output signals:

Encoder signals: 7 to 16 μA_{pp}, typical 11.5 μA_{pp} at 1 KΩ

Reference pulse: 2 to 8 μA,

typical 5 μA (useable component) at 1 KΩ

Max. output frequency:

100 kHz (with 3 m cable)

• Square wave signals (single ended) with integrated Subdividing Electronics

• Square wave signals (differential) via Line Driver RS 422 standard with integrated Subdividing Electronics

MSA 672.23 = times1

MSA 672.24 = times1

MSA 672.63 = times5

MSA 672.64 = times5

MSA 672.73 = times10

MSA 672.71 = times10

MSA 672.51 = times25

Power supply:

+5 V ±5%, max. 150 mA (unloaded)

MSA 672 Dimensions - Mounting tolerances - Mounting possibilities:

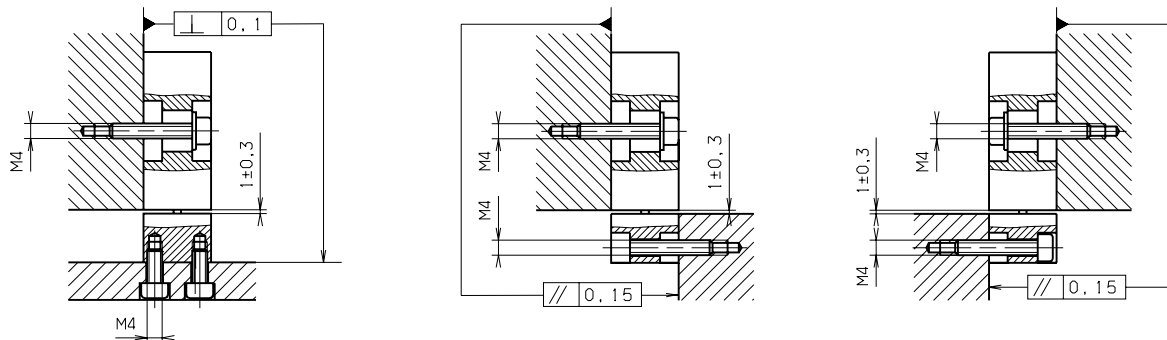
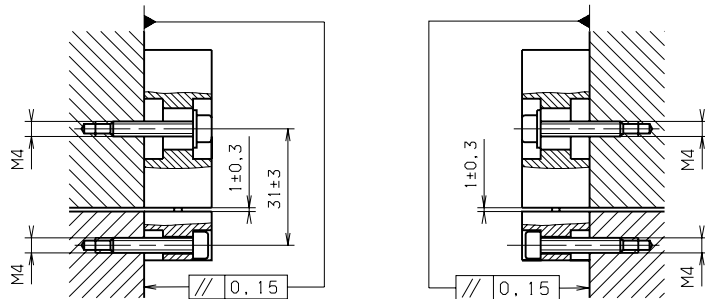
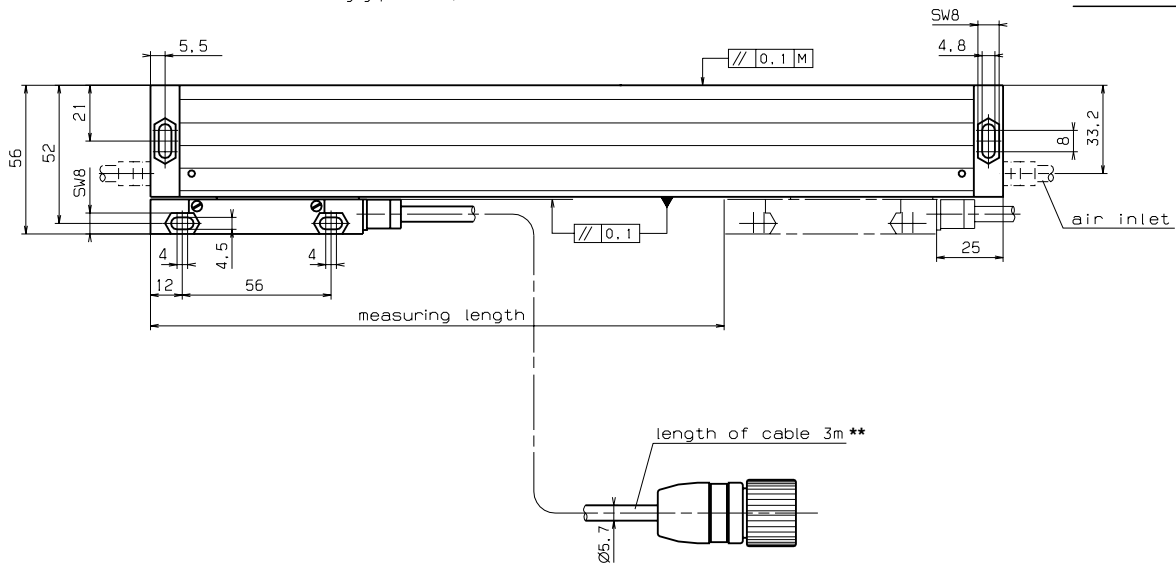
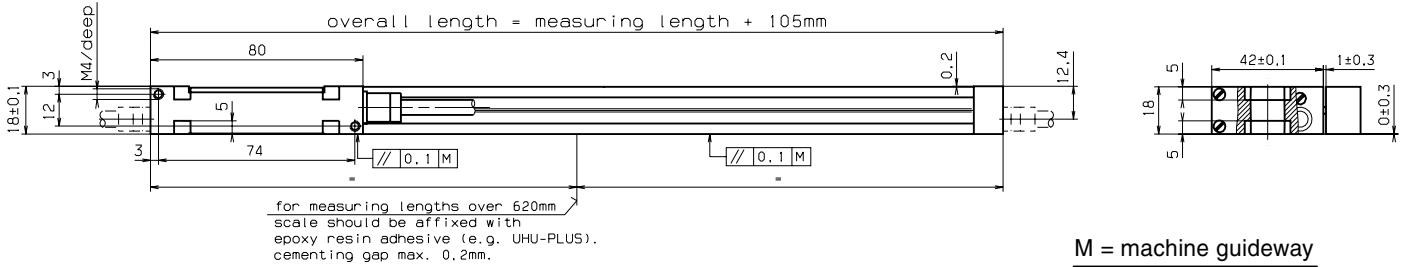
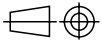

** armoured cable optional

MSA 680

Scale model	System resolution	Accuracy grades *	Grating pitch * (Edge separation a_{min})	Max. velocity continuous momentary	
• Sinusoidal voltage signals 1 V_{pp}					
MSA 680.03	depending on external subdividing	±3, ±5 μm/m	20 μm	1 m/s	2 m/s
MSA 680.01	depending on external subdividing	±2, ±3 μm/m	10 μm	1 m/s	1 m/s
• Sinusoidal micro-current signals					
MSA 680.13	depending on external subdividing	±3, ±5 μm/m	20 μm	1 m/s	2 m/s
MSA 680.11	depending on external subdividing	±2, ±3 μm/m	10 μm	1 m/s	1 m/s
• Square wave Line Driver signals with integrated Subdividing					
MSA 680.23	5 μm	±5 μm/m	20 μm	1 m/s (3.3 μs)	2 m/s (1.6 μs)
MSA 680.64	2 μm	±5 μm/m	40 μm	1 m/s (1.2 μs)	2 m/s (600 ns)
MSA 680.63	1 μm	±3, ±5 μm/m	20 μm	1 m/s (600 ns)	1 m/s (600 ns)
MSA 680.73	0.5 μm	±3, ±5 μm/m	20 μm	1 m/s (300 ns)	1 m/s (300 ns)
MSA 680.71	0.25 μm	±2, ±3, ±5 μm/m	10 μm	0.5 m/s (300 ns)	0.5 m/s (300 ns)
MSA 680.51	0.1 μm	±2, ±3, ±5 μm/m	10 μm	0.45 m/s (200 ns)	0.45 m/s (200 ns)
* Other accuracy grades or grating pitches (e.g. Inch) upon request					

Standard measuring lengths: (mm)

70, 120, 170, 220, 270, 320, 370, 420, 470, 520, 620, 720, 820, 920, 1040, 1140, 1240

Measuring type: glass scale

Reference Mark (RI): selectable

MSA 680.xx **K**:

Distance coded Reference Marks (**K**): after travelling 20 mm the absolute position will be shown on the display.

MSA 680.xx:

Up to a measuring length of 920 mm, one Reference Mark can either be placed in the middle of scales 1040 mm or longer, or 35 mm from either end of measuring length. With a measuring length of 1040 mm or longer, a Reference Mark will be placed 45 mm from either end of the measured length.

Option:

One Reference Mark at any location, or two or more Reference Marks separated by distances of $n \times 50$ mm

Required moving force:

with standard sealing lips < 3 N

with low drag sealing lips < 0.2 N

Environmental sealing DIN 40050:

IP 53 (with standard sealing lips)

IP 64 with DA300 (DA300 see page 45)

Permissible vibration: 100 m/s² (40 to 2000 Hz)

Permissible shock: 200 m/s² (8 ms)

Permissible temperature:

-20°C to +70°C (storage), 0°C to +50°C (operation)

Weight (approx.)

0.8 kg/m (scale spar) + 75 g (scanning head without cable)

Signal-outputs (optional):

• Sinusoidal voltage signals

MSA 680.03

MSA 680.01

Power supply:

+5V ±5%, max. 120 mA (unloaded)

Output signals:

Encoder signals: 0.6 to 1.2 V_{pp}, typical 1 V_{pp} with terminating resistor $Z_0 = 120 \Omega$

Reference pulse:

0.2 to 0.85 V_{pp}, typical 0.4 V (useable component) with terminating resistor $Z_0 = 120 \Omega$

Max. output frequency:

100 kHz (with 3 m cable)

• Sinusoidal micro-current signals

MSA 680.13

MSA 680.11

Power supply:

+5V ±5%, max. 120 mA

Output signals:

Encoder signals: 7 to 16 μApp, typical 11.5 μApp at 1 KΩ

Reference pulse: 2 to 8 μA,

typical 5 μA (useable component) at 1 KΩ

Max. output frequency:

100 kHz (with 3 m cable)

• Square wave signals (single ended) with integrated Subdividing Electronics

• Square wave signals (differential) via Line Driver RS 422 standard with integrated Subdividing Electronics

MSA 680.23 = times1

MSA 680.63 = times5

MSA 680.64 = times5

MSA 680.73 = times10

MSA 680.71 = times10

MSA 680.51 = times25

Power supply:

+5 V ±5%, max. 150 mA (unloaded)

MSA 680 Dimensions - Mounting tolerances - Mounting possibilities:

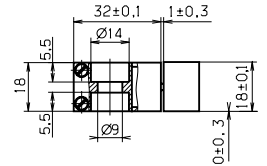
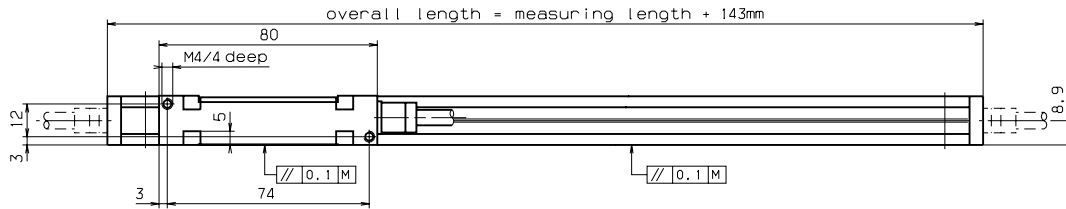
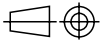

M = machine guideway

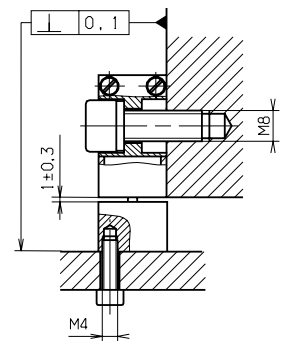
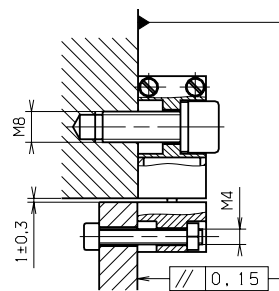
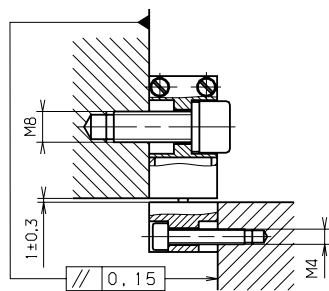
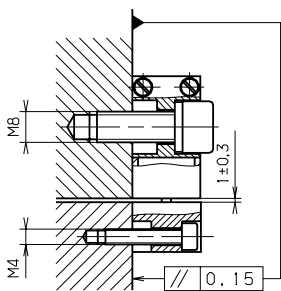
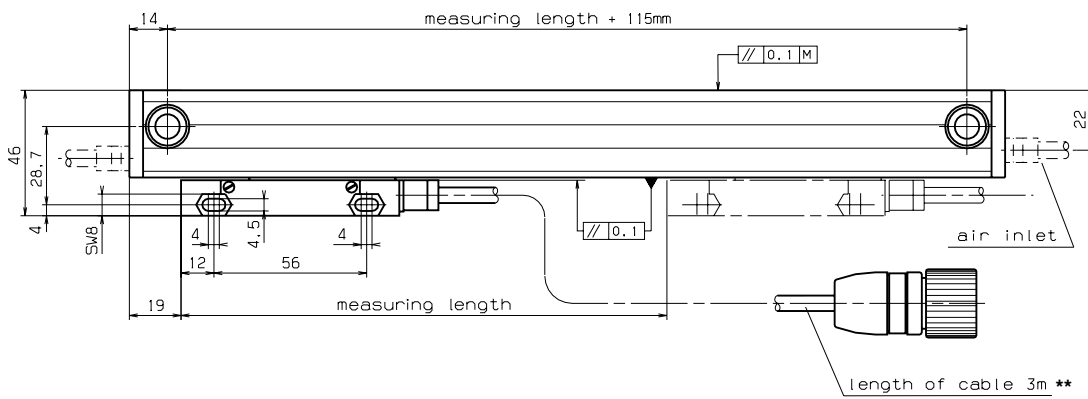

** armoured cable optional

MSA 370

MSA 390 (with switch signals and selectable Reference Mark)

Scale model	System resolution	Accuracy grades *	Grating pitch * (Edge separation a_{min})	Max. velocity continuous momentary	
-------------	-------------------	-------------------	--	---------------------------------------	--

• Sinusoidal voltage signals 1 V_{pp}

MSA 370.03	depending on external subdividing	±3, ±5, ±10 μm/m	20 μm	1 m/s	2 m/s
MSA 370.01	depending on external subdividing	±2, ±3 μm/m	10 μm	1 m/s	1 m/s

• Sinusoidal micro-current signals

MSA 370.13	depending on external subdividing	±3, ±5, ±10 μm/m	20 μm	1 m/s	2 m/s
MSA 370.11	depending on external subdividing	±2, ±3 μm/m	10 μm	1 m/s	1 m/s

• Square wave Line Driver signals with integrated Subdividing

MSA 370.24	10 μm	±10 μm/m	40 μm	1 m/s (6.6 μs)	2 m/s (3.3 μs)
MSA 370.23	5 μm	±5, ±10 μm/m	20 μm	1 m/s (3.3 μs)	2 m/s (1.6 μs)
MSA 370.64	2 μm	±5 μm/m	40 μm	1 m/s (1.2 μs)	2 m/s (600 ns)
MSA 370.63	1 μm	±3, ±5 μm/m	20 μm	1 m/s (600 ns)	1 m/s (600 ns)
MSA 370.73	0.5 μm	±3, ±5 μm/m	20 μm	1 m/s (300 ns)	1 m/s (300 ns)
MSA 370.71	0.25 μm	±2, ±3, ±5 μm/m	10 μm	0.5 m/s (300 ns)	0.5 m/s (300 ns)
MSA 370.51	0.1 μm	±2, ±3, ±5 μm/m	10 μm	0.45 m/s (200 ns)	0.45 m/s (200 ns)

* Other accuracy grades or grating pitches (e.g. Inch) upon request

Standard measuring lengths: (mm)

170, 220, 270, 320, 370, 420, 470, 520, 620, 720, 770, 820, 920, 1040, 1140, 1240, 1340, 1440, 1540, 1640, 1740, 1840, 2040, 2240, 2440, 2640, 2840, 3040

Measuring type: glass scale

Reference Mark (RI): selectable

MSA 370.xx K:

Distance coded Reference Marks (K): after travelling 20 mm the absolute position will be shown on the display.

MSA 370.xx (MSA 390.xx Option):

Up to a measuring length of 920 mm, one Reference Mark can either be placed in the middle of scales 1040 mm or longer, or 35 mm from either end of measuring length. With a measuring length of 1040 mm or longer, a Reference Mark will be placed 45 mm from either end of the measured length.

MSA 370.xx Option:

One Reference Mark at any location, or two or more Reference Marks separated by distances of n x 50 mm

MSA 390.xx **Selectable Reference Mark (RI):**

Standard: A customized positioned switch magnet activates one of the Reference Marks, which are disposed by distances of n x 50 mm.

The label at the extrusion marks the position of the first Reference Mark.

The free positionable switching magnet is used for individual function (instead selectable Reference Mark).

The switch track (S-RI) will be accomplished (details on page 32 and 33)

MSA 390.xx:

Free positionable switching magnets for special functions:

The position of the 2 switch points (S1 and S2) within the measured length can be selected by the customer (details on page 32 and 33).

Required moving force: with standard sealing lips < 3 N
with low drag sealing lips < 0.2 N

Signal-outputs (optional):

- Sinusoidal voltage signals
MSA 370.03
MSA 370.01

Power supply:

+5V ±5%, max. 120 mA (unloaded)

Output signals:

Encoder signals: 0.6 to 1.2 V_{pp}, typical 1 V_{pp}
with terminating resistor Z_o = 120 Ω

Reference pulse:

0.2 to 0.85 V_{pp}, typical 0.4 V (useable component)
with terminating resistor Z_o = 120 Ω

Max. output frequency:

100 kHz (with 3 m cable)

- Sinusoidal micro-current signals
MSA 370.13
MSA 370.11

Power supply:

+5V ±5%, max. 120 mA

Output signals:

Encoder signals: 7 to 16 μA_{pp},
typical 11.5 μA_{pp} at 1 KΩ

Reference pulse: 2 to 8 μA,

typical 5 μA (useable component) at 1 KΩ

Max. output frequency:

100 kHz (with 3 m cable)

- Square wave signals (single ended)
with integrated Subdividing Electronics

- Square wave signals (differential)
via Line Driver RS 422 standard
with integrated Subdividing Electronics

MSA 370.23 = times1

MSA 370.24 = times1

MSA 370.63 = times5

MSA 370.64 = times5

MSA 370.73 = times10

MSA 370.71 = times10

MSA 370.51 = times25

Power supply:

+5 V ±5%, max. 150 mA (unloaded)

Environmental sealing DIN 40050:

IP 53 (with standard sealing lips)

IP 64 with DA300 (DA300 see page 45)

Permissible vibration: 150 m/s² (40 to 2000 Hz)

Permissible shock: 300 m/s² (8 ms)

Permissible temperature:

-20°C to +70°C (storage), 0°C to +50°C (operation)

Weight (approx.):

3 kg/m (scale spar) + 245 g (scanning head without cable)

MSA 370, MSA 390 Dimensions - Mounting tolerances - Mounting possibilities:

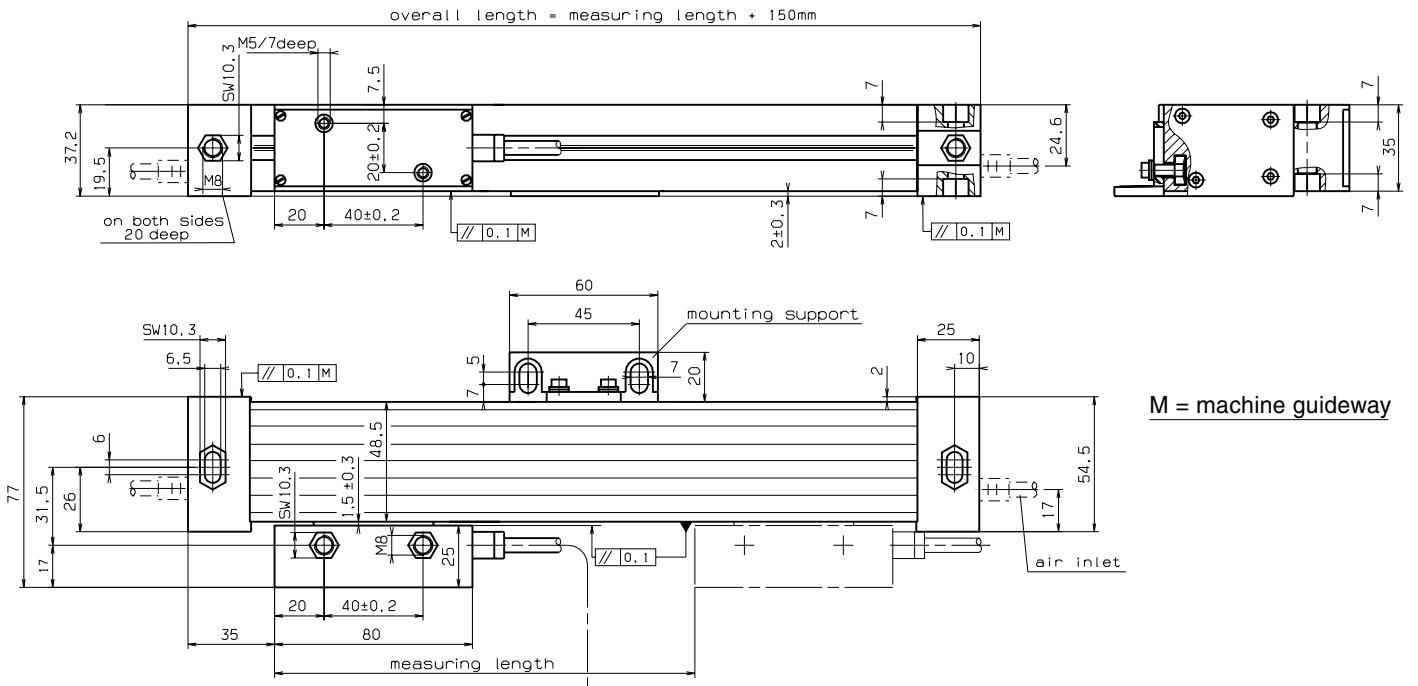
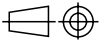

M = machine guideway

quantity and position of the mounting support per measuring length

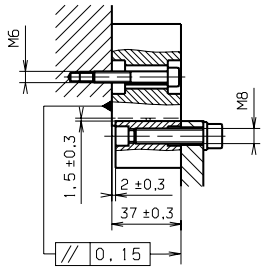
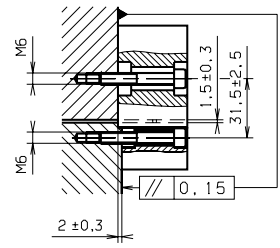
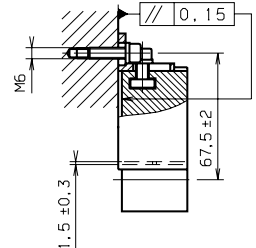
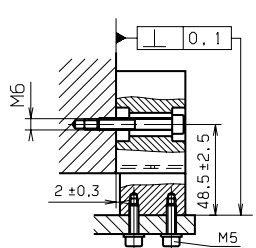
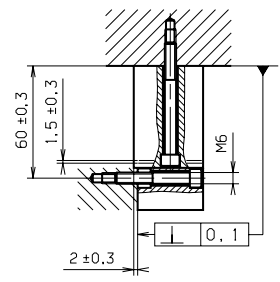
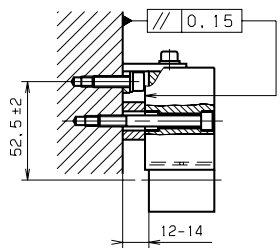
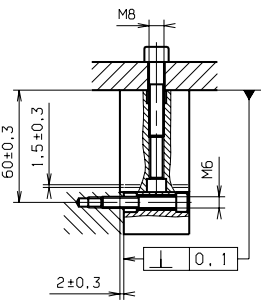
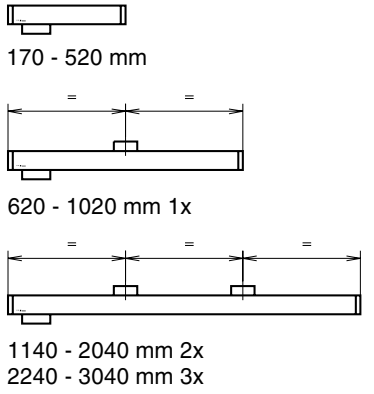

** armoured cable optional

MSA 371

MSA 391 (with switch signals and selectable Reference Mark)

Scale model	System resolution	Accuracy grades*	Grating pitch* (Edge separation a_{min})	Max. velocity (continuous momentary)	
• Sinusoidal voltage signals 1 V_{pp}					
MSA 371.03	depending on external subdividing	±3, ±5, ±10 μm/m	20 μm	1 m/s	2 m/s
MSA 371.01	depending on external subdividing	±2, ±3 μm/m	10 μm	1 m/s	1 m/s
• Sinusoidal micro-current signals					
MSA 371.13	depending on external subdividing	±3, ±5, ±10 μm/m	20 μm	1 m/s	2 m/s
MSA 371.11	depending on external subdividing	±2, ±3 μm/m	10 μm	1 m/s	1 m/s
• Square wave Line Driver signals with integrated Subdividing					
MSA 371.24	10 μm	±10 μm/m	40 μm	1 m/s (6.6 μs)	2 m/s (3.3 μs)
MSA 371.23	5 μm	±5, ±10 μm/m	20 μm	1 m/s (3.3 μs)	2 m/s (1.6 μs)
MSA 371.64	2 μm	±5 μm/m	40 μm	1 m/s (1.2 μs)	2 m/s (600 ns)
MSA 371.63	1 μm	±3, ±5 μm/m	20 μm	1 m/s (600 ns)	1 m/s (600 ns)
MSA 371.73	0.5 μm	±3, ±5 μm/m	20 μm	1 m/s (300 ns)	1 m/s (300 ns)
MSA 371.71	0.25 μm	±2, ±3, ±5 μm/m	10 μm	0.5 m/s (300 ns)	0.5 m/s (300 ns)
MSA 371.51	0.1 μm	±2, ±3, ±5 μm/m	10 μm	0.45 m/s (200 ns)	0.45 m/s (200 ns)

* Other accuracy grades or grating pitches (e.g. Inch) upon request

Standard measuring lengths: (mm)

170, 220, 270, 320, 370, 420, 470, 520, 620, 720, 770, 820, 920, 1040, 1140, 1240, 1340, 1440, 1540, 1640, 1740, 1840, 2040, 2240, 2440, 2640, 2840, 3040

Measuring type: glass scale

Reference Mark (RI): selectable

MSA 371.xx K:

Distance coded Reference Marks (K): after travelling 20 mm the absolute position will be shown on the display.

MSA 371.xx (MSA 391.xx Option):

Up to a measuring length of 920 mm, one Reference Mark can either be placed in the middle of scales 1040 mm or longer, or 35 mm from either end of measuring length. With a measuring length of 1040 mm or longer, a Reference Mark will be placed 45 mm from either end of the measured length.

MSA 371.xx Option:

One Reference Mark at any location, or two or more Reference Marks separated by distances of n x 50 mm

MSA 391.xx Selectable Reference Mark (RI):

Standard: A customized positioned switch magnet activates one of the Reference Marks, which are disposed by distances of n x 50 mm.

The label at the extrusion marks the position of the first Reference Mark.

The free positionable switching magnet is used for individual function (instead selectable Reference Mark).

The switch track (S-RI) will be accomplished (details on page 32 and 33).

MSA 391.xx

Free positionable switching magnets for special functions:

The position of the 2 switch points (S1 and S2) within the measured length can be selected by the customer (details on page 32 and 33)

Required moving force: with standard sealing lips < 3 N
with low drag sealing lips < 0.2 N

Signal-outputs (optional):

• Sinusoidal voltage signals

MSA 371.03

MSA 371.01

Power supply:

+5V ±5%, max. 120 mA (unloaded)

Output signals:

Encoder signals: 0.6 to 1.2 V_{pp}, typical 1 V_{pp}
with terminating resistor Z₀ = 120 Ω

Reference pulse:

0.2 to 0.85 V_{pp}, typical 0.4 V (useable component)
with terminating resistor Z₀ = 120 Ω

Max. output frequency:

100 kHz (with 3 m cable)

• Sinusoidal micro-current signals

MSA 371.13

MSA 371.11

Power supply:

+5V ±5%, max. 120 mA

Output signals:

Encoder signals: 7 to 16 μA_{pp},
typical 11.5 μA_{pp} at 1 KΩ

Reference pulse: 2 to 8 μA,

typical 5 μA (useable component) at 1 KΩ

Max. output frequency:

100 kHz (with 3 m cable)

• Square wave signals (single ended) with integrated Subdividing Electronics

• Square wave signals (differential) via Line Driver RS 422 standard with integrated Subdividing Electronics

MSA 371.23 = times1

MSA 371.24 = times1

MSA 371.63 = times5

MSA 371.64 = times5

MSA 371.73 = times10

MSA 371.71 = times10

MSA 371.51 = times25

Power supply:

+5 V ±5%, max. 150 mA (unloaded)

Environmental sealing DIN 40050:

IP 53 (with standard sealing lips)

IP 64 with DA300 (DA300 see page 57)

Permissible vibration: 150 m/s² (40 to 2000 Hz)

Permissible shock: 300 m/s² (8 ms)

Permissible temperature:

20°C to +70°C (storage), 0°C to +50°C (operation)

Weight (approx.)

3 kg/m (scale spar) + 245 g (scanning head without cable)

MSA 371, MSA 391 Dimensions - Mounting tolerances - Mounting possibilities:

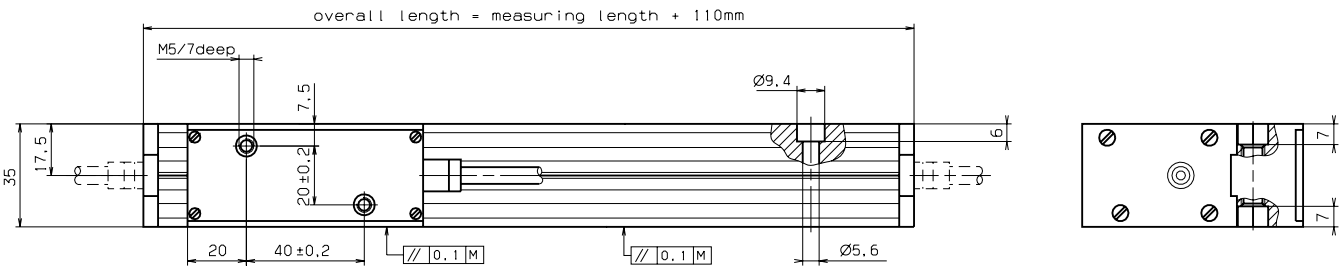
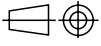

M = machine guideway

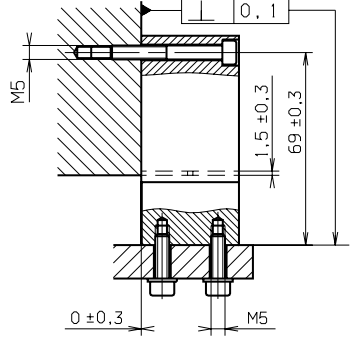
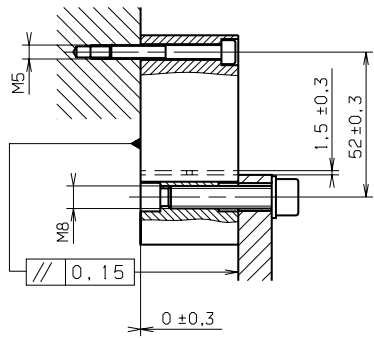
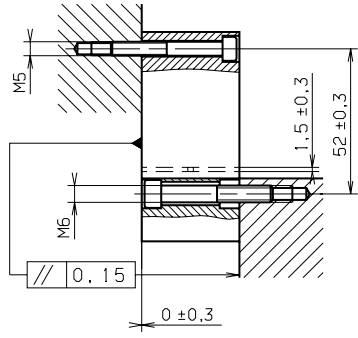
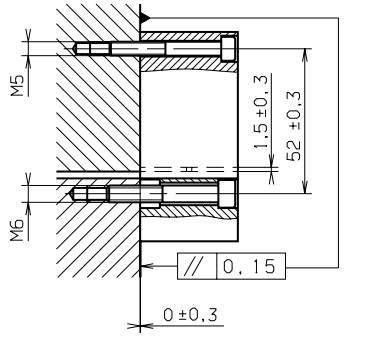
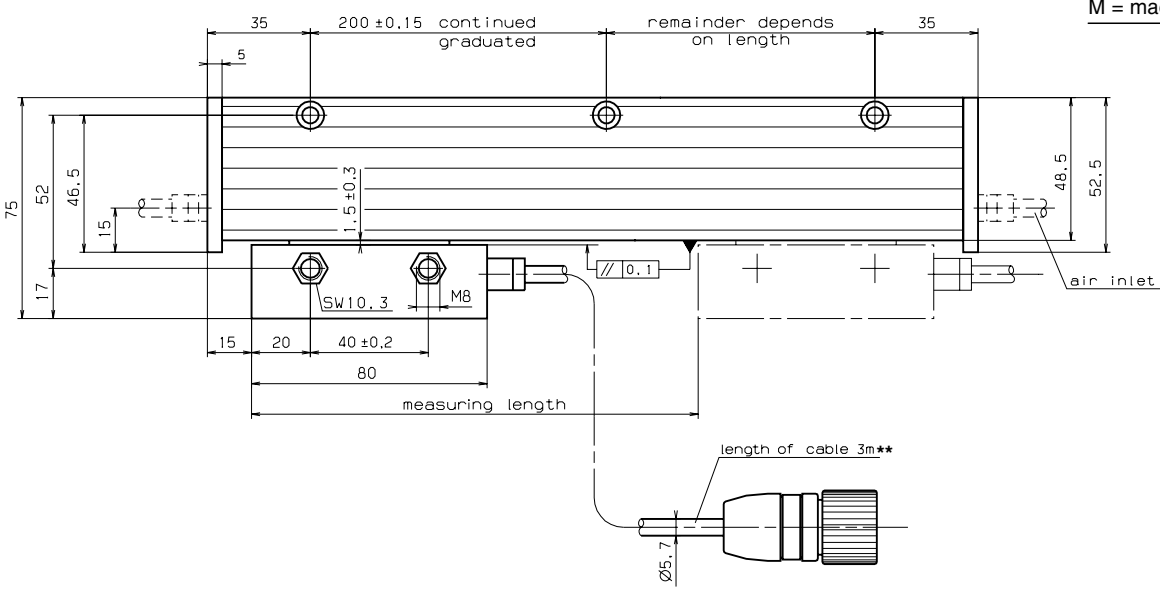

** armoured cable optional

MSA 372

Scale model	System resolution	Accuracy grades *	Grating pitch (Edge separation a _{min}) *	Max. velocity continuous momentary	
• Sinusoidal voltage signals 1 V_{pp}					
MSA 372.03	depending on external subdividing	±3, ±5, ±10 μm/m	20 μm	1 m/s	2 m/s
MSA 372.01	depending on external subdividing	±2, ±3 μm/m	10 μm	1 m/s	1 m/s
• Sinusoidal micro-current signals					
MSA 372.13	depending on external subdividing	±3, ±5, ±10 μm/m	20 μm	1 m/s	2 m/s
MSA 372.11	depending on external subdividing	±2, ±3 μm/m	10 μm	1 m/s	1 m/s
• Square wave Line Driver signals with integrated Subdividing					
MSA 372.24	10 μm	±10 μm/m	40 μm	1 m/s (6.6 μs)	2 m/s (3.3 μs)
MSA 372.23	5 μm	±5, ±10 μm/m	20 μm	1 m/s (3.3 μs)	2 m/s (1.6 μs)
MSA 372.64	2 μm	±5 μm/m	40 μm	1 m/s (1.2 μs)	2 m/s (600 ns)
MSA 372.63	1 μm	±3, ±5 μm/m	20 μm	1 m/s (600 ns)	1 m/s (600 ns)
MSA 372.73	0.5 μm	±3, ±5 μm/m	20 μm	1 m/s (300 ns)	1 m/s (300 ns)
MSA 372.71	0.25 μm	±2, ±3, ±5 μm/m	10 μm	0.5 m/s (300 ns)	0.5 m/s (300 ns)
MSA 372.51	0.1 μm	±2, ±3, ±5 μm/m	10 μm	0.45 m/s (200 ns)	0.45 m/s (200 ns)

* Other accuracy grades or grating pitches (e.g. Inch) upon request

Standard measuring lengths: (mm)

170, 220, 270, 320, 370, 420, 470, 520, 620, 720, 770, 820, 920, 1040, 1140, 1240, 1340, 1440, 1540, 1640, 1740, 1840, 2040, 2240, 2440, 2640, 2840, 3040

Measuring type: glass scale

Reference Mark (RI): selectable

MSA 372.xx K:

Distance coded Reference Marks (K): after travelling 20 mm the absolute position will be shown on the display.

MSA 372.xx:

Up to a measuring length of 920 mm, one Reference Mark can either be placed in the middle of scales 1040 mm or longer, or 35 mm from either end of measuring length. With a measuring length of 1040 mm or longer, a Reference Mark will be placed 45 mm from either end of the measured length.

Option:

One Reference Mark at any location, or two or more Reference Marks separated by distances of n x 50 mm

Required moving force:

< 6 N (two sets of sealing lips)

Environmental sealing DIN 40050:

IP 54 (two sets of sealing lips)

IP 64 with DA300 (DA300 see page 45)

Permissible vibration: 150 m/s² (40 to 2000 Hz)

Permissible shock: 300 m/s² (8 ms)

Permissible temperature:

-20°C to +70°C (storage), 0°C to +50°C (operation)

Weight (approx.)

3 kg/m (scale spar) + 245 g (scanning head without cable)

Signal-outputs (optional):

- Sinusoidal voltage signals
MSA 372.03
MSA 372.01

Power supply:

+5V ±5%, max. 120 mA (unloaded)

Output signals:

Encoder signals: 0.6 to 1.2 V_{pp}, typical 1 V_{pp} with terminating resistor Z_o = 120 Ω

Reference pulse:

0.2 to 0.85 V_{pp}, typical 0.4 V (useable component) with terminating resistor Z_o = 120 Ω

Max. output frequency:

100 kHz (with 3 m cable)

- Sinusoidal micro-current signals
MSA 372.13
MSA 372.11

Power supply:

+5V ±5%, max. 120 mA

Output signals:

Encoder signals: 7 to 16 μA_{pp}, typical 11.5 μA_{pp} at 1 KΩ

Reference pulse: 2 to 8 μA,

typical 5 μA (useable component) at 1 KΩ

Max. output frequency:

100 kHz (with 3 m cable)

- Square wave signals (single ended) with integrated Subdividing Electronics

- Square wave signals (differential) via Line Driver RS 422 standard with integrated Subdividing Electronics

MSA 372.23 = times1

MSA 372.24 = times1

MSA 372.63 = times5

MSA 372.64 = times5

MSA 372.73 = times10

MSA 372.71 = times10

MSA 372.51 = times25

Power supply:

+5 V ±5%, max. 150 mA (unloaded)

MSA 372 Dimensions - Mounting tolerances - Mounting possibilities:

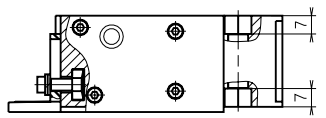
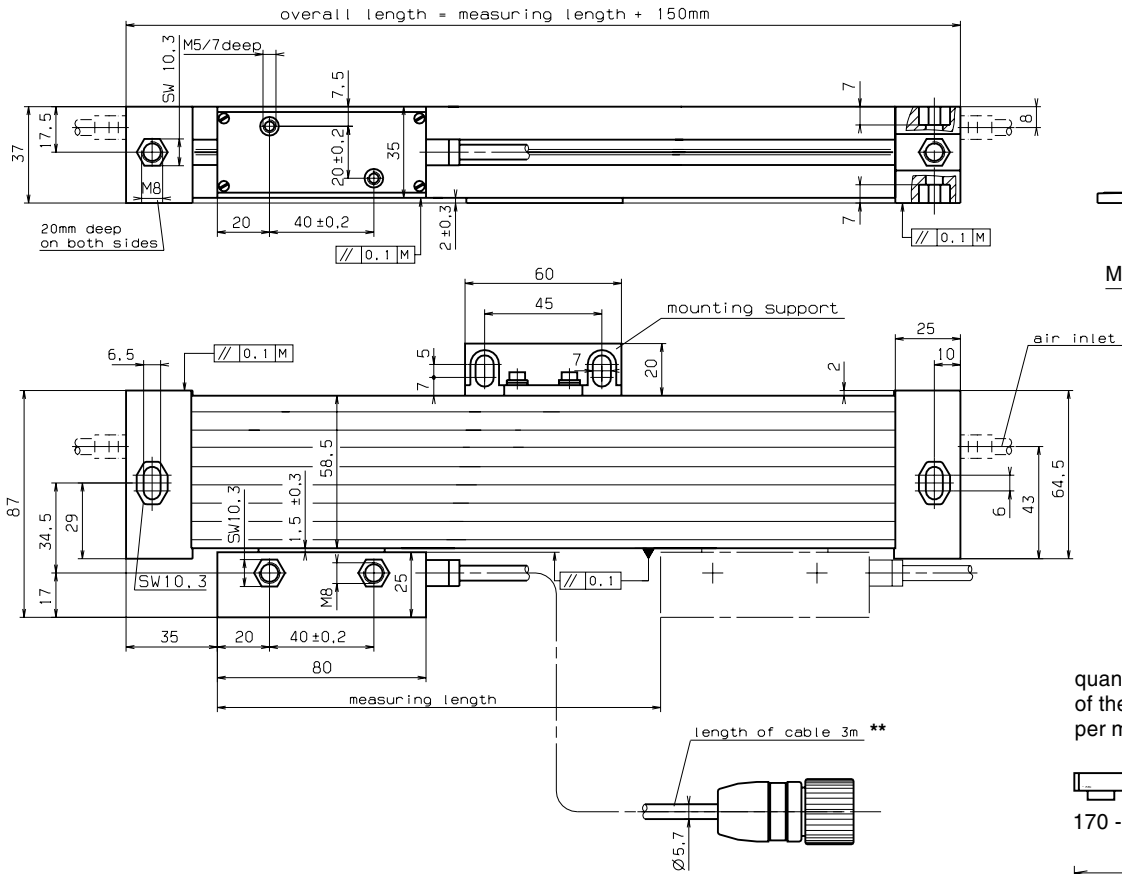
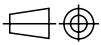

M = machine guideway

quantity and position of the mounting support per measuring length

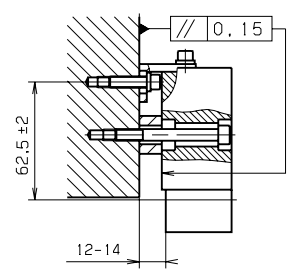
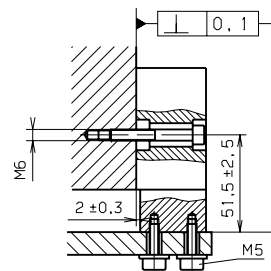
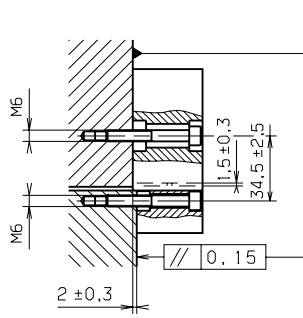
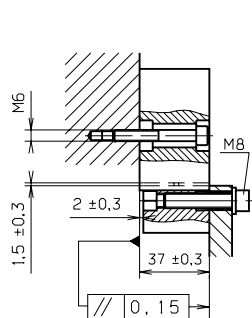
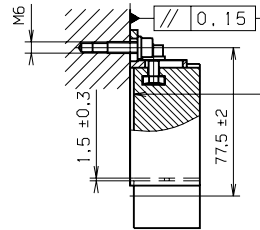
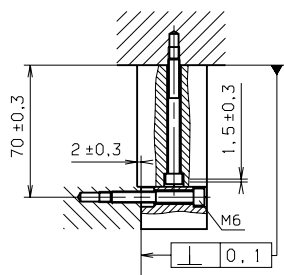
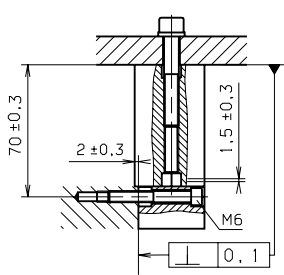
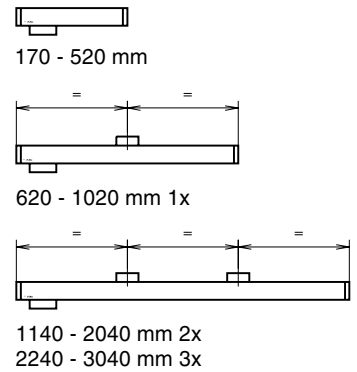

** armoured cable optional

MSA 373, MSA 374, MSA 375

Scale model	System resolution	Accuracy grades *	Grating pitch *	Max. velocity
-------------	-------------------	-------------------	-----------------	---------------

• Square wave Line Driver signals with integrated Subdividing

MSA 374.65	5 μm	$\pm 10 \mu\text{m/m}$	100 μm	1 m/s (1.6 μs)
MSA 374.55	1 μm	$\pm 10 \mu\text{m/m}$	100 μm	1 m/s (800 ns)

* Other accuracy grades or grating pitches (e.g. Inch) upon request

Standard measuring lengths: (mm)

70, 120, 170, 220, 270, 320, 370, 420, 470, 520, 620, 720 (longer measuring lengths on request)

Max. range of traverse = ML + 26 mm (ML + 2 x Overtravel)

Signal-outputs (optional):

• Square wave signals (single ended) with integrated Subdividing Electronics

• Square wave signals (differential) via Line Driver RS 422 standard with integrated Subdividing Electronics
MSA 374.65 = times 5
MSA 374.55 = times 25

Power supply:

+5 V $\pm 5\%$, max. 120 mA (unloaded)

Measuring type: glass scale

Optional:

Free positionable switching magnets for special functions:

The position of the 2 switch points (S1 and S2) within the measured length can be selected by the customer

Reference Mark (RI):

Standard: One Reference Mark in the middle of the measuring length, or 35 mm from either end of the measured length.

Option: One Reference Mark at any location, or two or more Reference Marks separated by distances of $n \times 50$ mm.

Required moving force: < 5 N

Environmental sealing DIN 40050:

IP 53 (with standard sealing lips), IP 64 with DA300 (optional)

Permissible vibration: 150 m/s^2 (40 to 2000 Hz), Permissible shock: 300 m/s^2 (8 ms)

Permissible temperature: -20°C to +70°C (storage), 0°C to +50°C (operation)

Weight MSA 374 (approx.): 280g + 1.34 g pro mm (scale spar) + 210 g (scanning head without cable)

MSA 374 Dimensions - Mounting tolerances

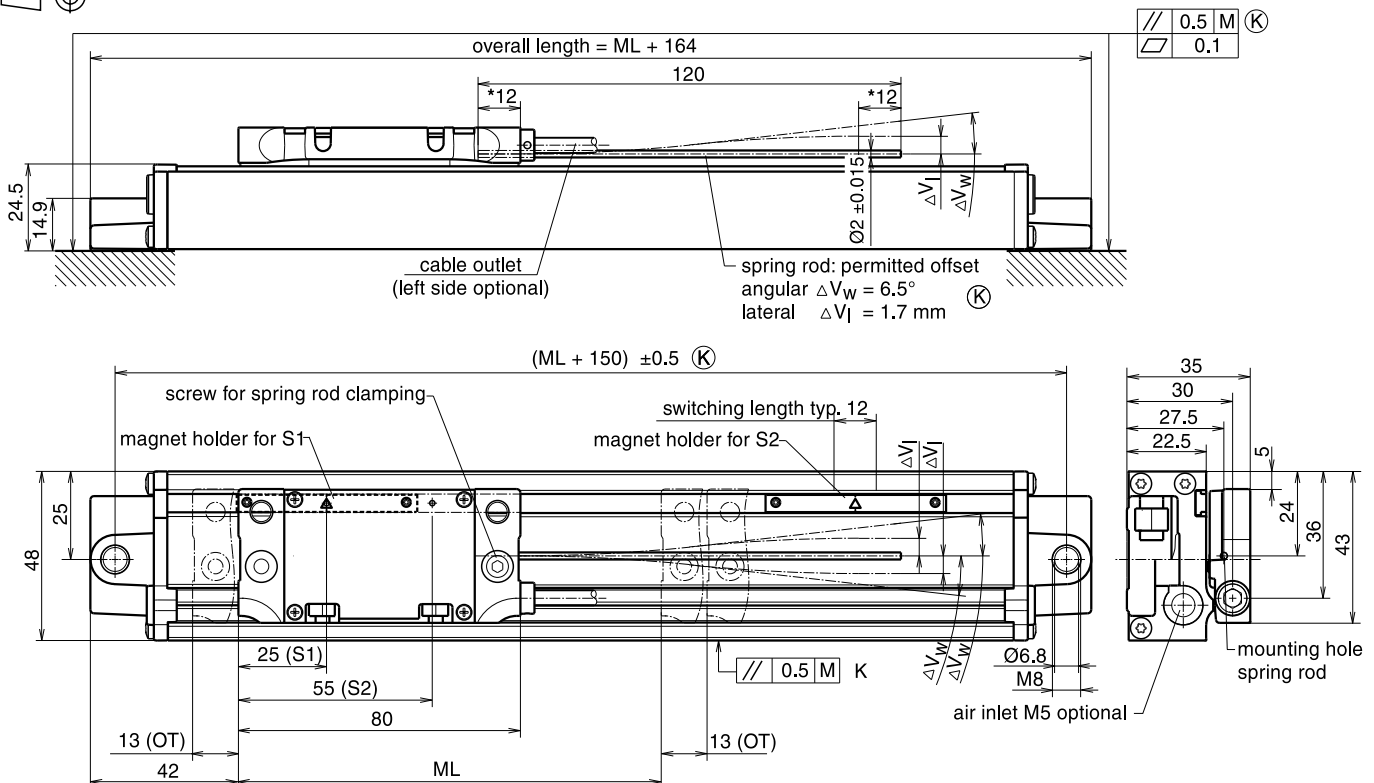
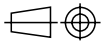

S1, S2 position of the sensors in the encoder head, switching length typ. 12 mm
 switch position S1 and S2 free selectable (allen wrench 0.9 mm)
 spring rod clamping left side possible (allen wrench 3 mm)
 * clamping length spring rod

ML = measuring length

M = machine guideway

OT = overtravel

Ⓚ = customer mounting dimensions

MSA 373

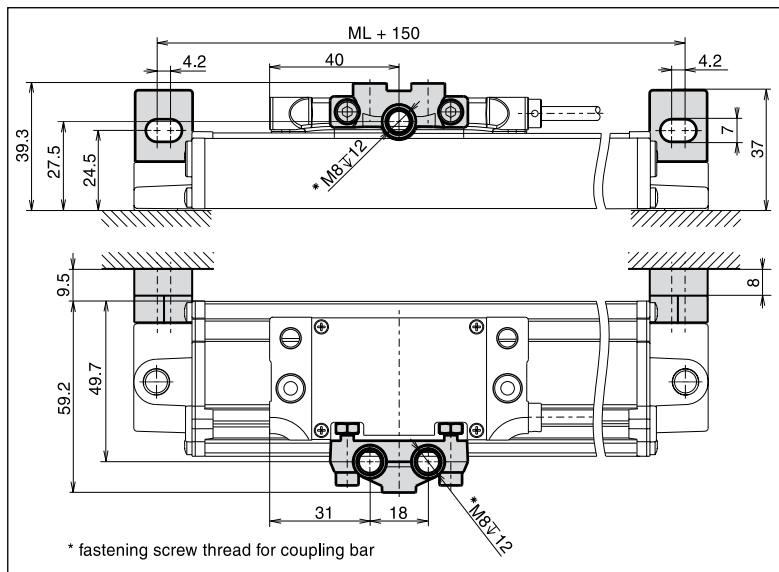

MSA 375

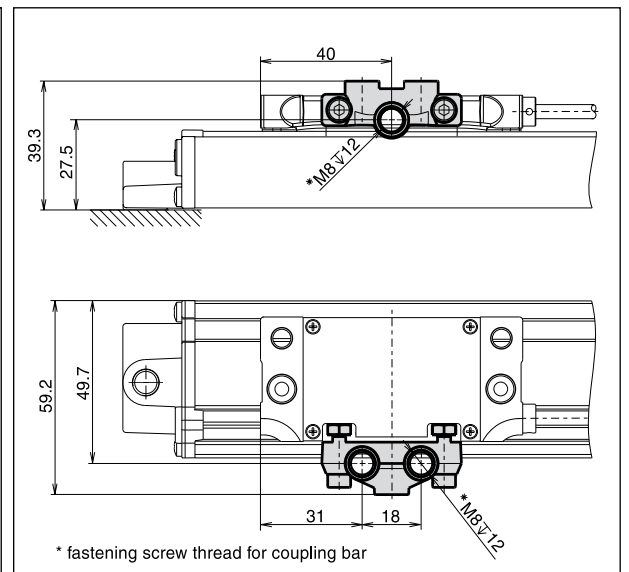

Accessory:

CB8 - 150 Coupling bar (only for MSA 373 and 375)

Axis distance 150 mm (Other axis distances on request)

Included in delivery: 2 Hexagon socket screws M8 x 20 ISO 4762 for mounting

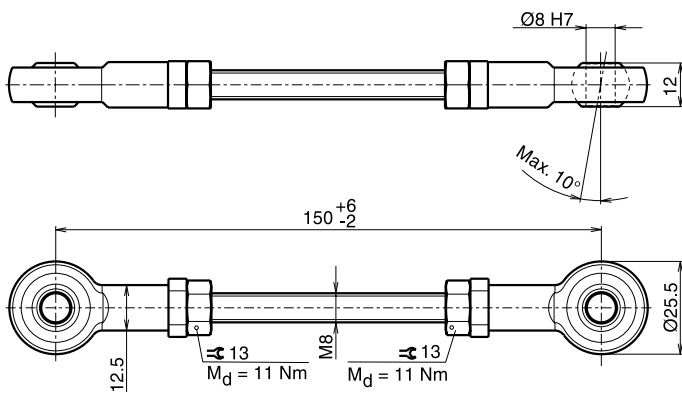

Caution:

Observe maximum angular deflection!

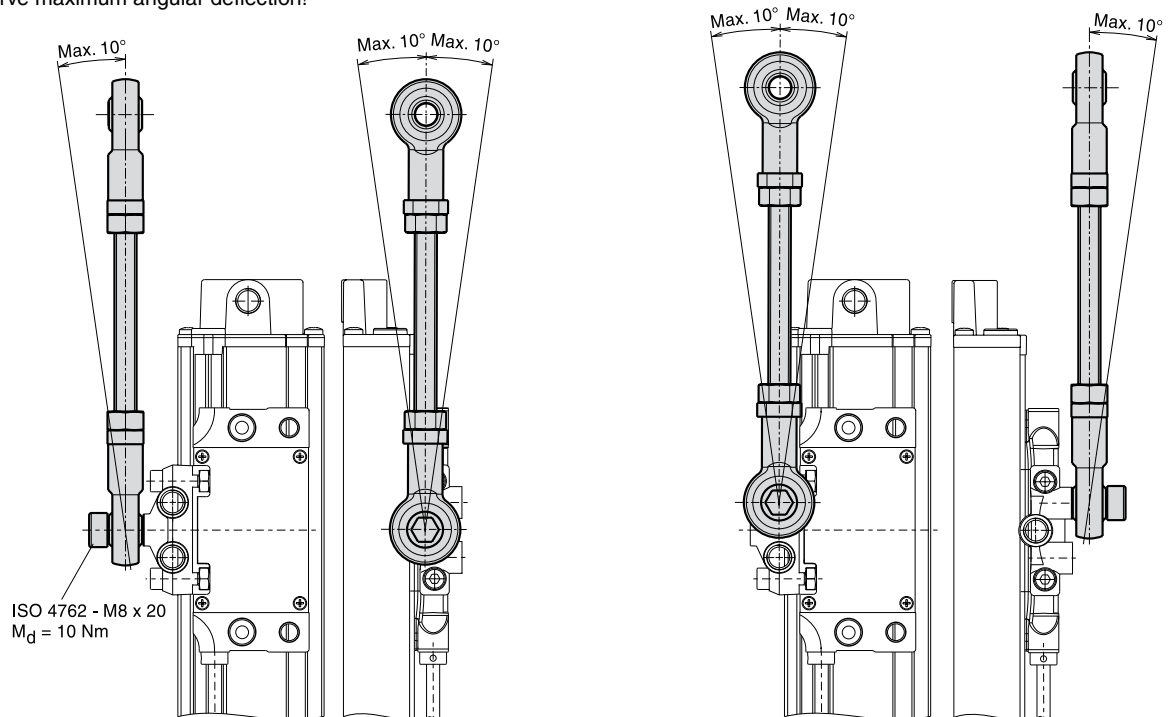

Positioning of the switching magnets

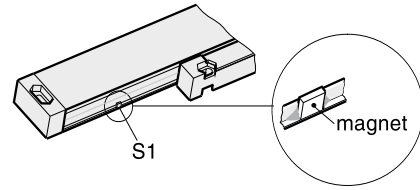
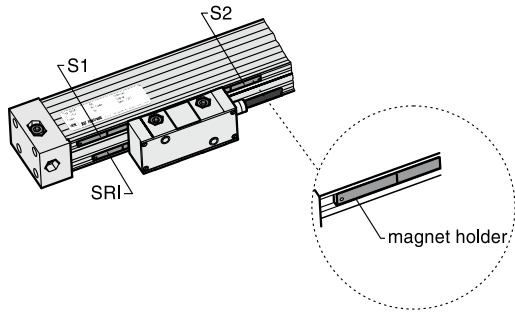

Switch points S1 and S2 for individual function MSA 690

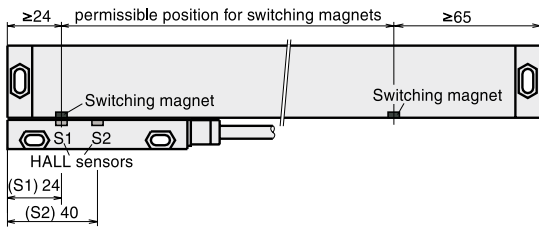

MSA 691

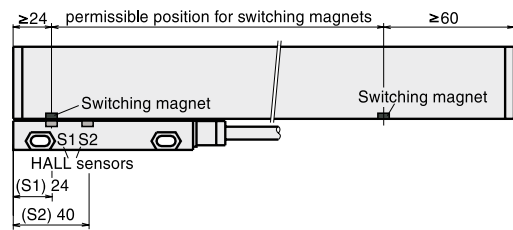

MSA 373, MSA 374, MSA 375

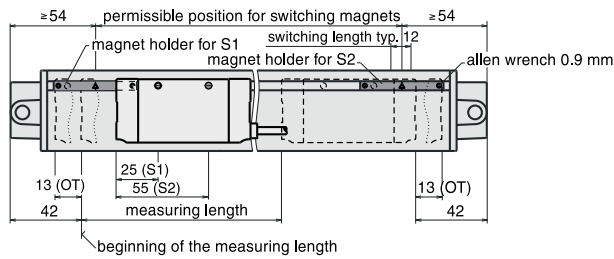

MSA 391

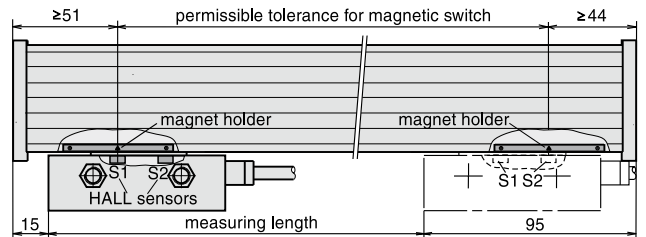

MSA 390

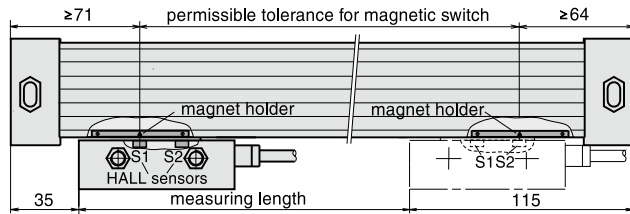

Selectable Reference mark (RI)

MSA 390

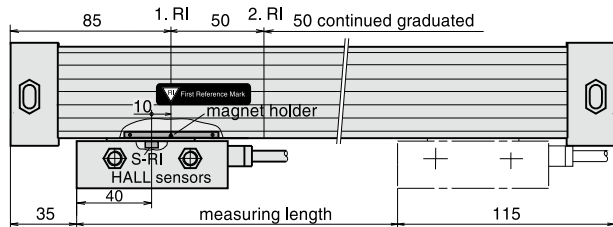

MSA 391

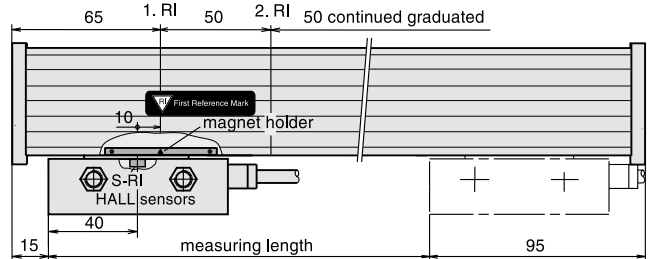

Version without RI-variety: Switch point S3 for additionally individual function

MSA 390

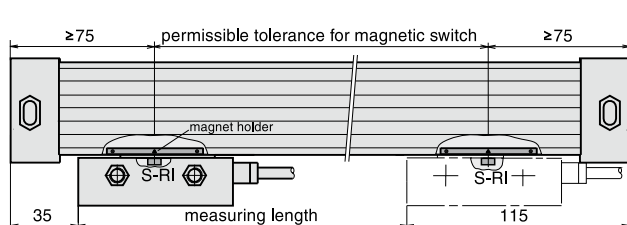

MSA 391

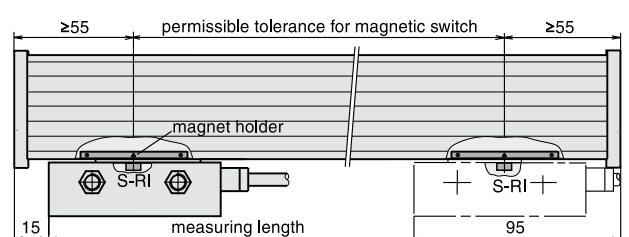

Pin-outs

MSA 690, MSA 691, MSA 390, MSA 391, MSA 373, MSA 374, MSA 375

SUB MIN-D connector 15-pin

PIN	1*	2**	3	4	5	6	7***	8	9	10	11	12	13	14	15
square wave signals via Line Driver	nc	GND	nc	RI	T2	T1	+5V	+5V	GND	S1	S2	RI	T2	T1	shield
sinusoidal micro-current signals	nc	GND	nc	RI-	90°-	0°-	+5V	+5V	GND	S1	S2	RI+	90°+	0°+	inner shield
sinusoidal voltage signals	nc	GND	nc	RI	A2	A1	+5V	+5V	GND	S1	S2	RI	A2	A1	inner shield

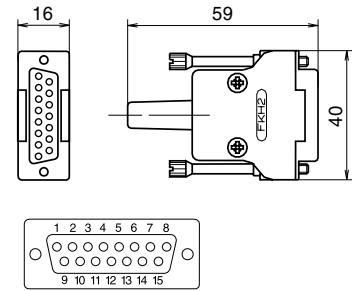

* exception at MSA 390 and MSA 391 (Version without RI-variety): PIN 1 = S-RI (switch output)

** PIN 2 = GND (bridge to PIN 9) or sensor

*** PIN 7 = +5V (bridge to PIN 8) or sensor

outer shield on chassis

Switch signals

MSA 690, MSA 691, MSA 390, MSA 391, MSA 373, MSA 374, MSA 375

Version 1

TTL output (active high)

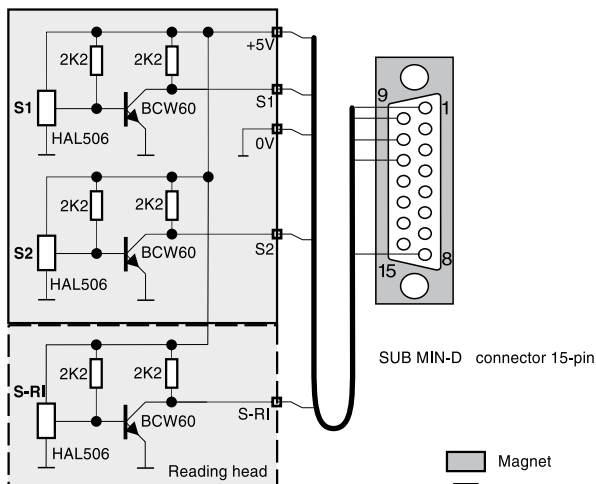

S1, S2, S-RI = TTL output

$I_{SOURCE} = 1 \text{ mA}$ (high level > 2 V)

$I_{SINK} = 20 \text{ mA}$ (low level < 0,8 V)



Version 2

open collector output (active high impedance)

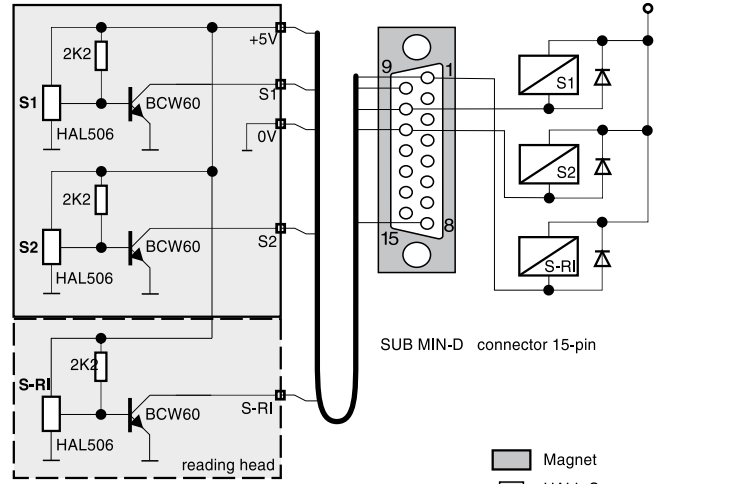

S1, S2, S-RI = open collector output

$I_{SINK} = 20 \text{ mA}$ (low level < 0,8 V)



Version 3

TTL output (active low)

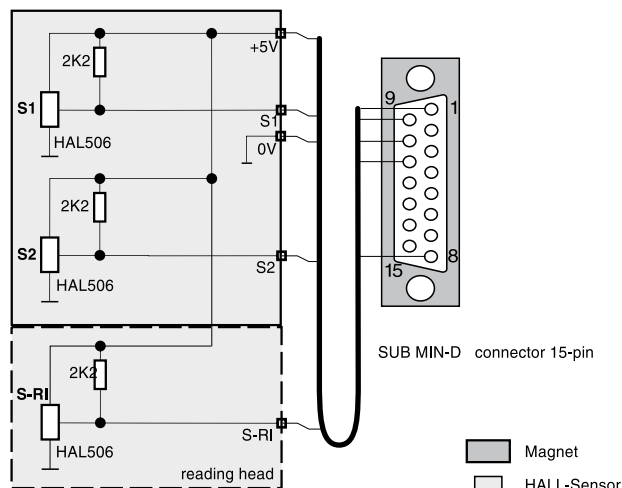

S1, S2, S-RI = TTL output

$I_{SOURCE} = 1 \text{ mA}$ (high level > 2 V)

$I_{SINK} = 20 \text{ mA}$ (low level < 0,8 V)



Version 4

open collector output (active low)

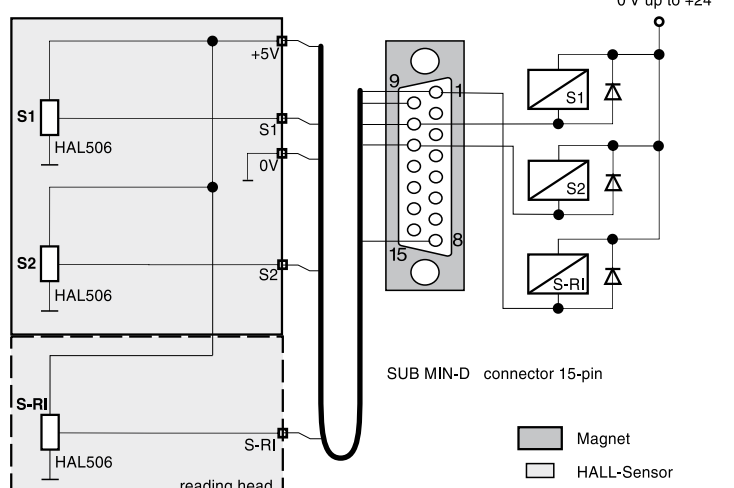

S1, S2, S-RI = open collector output

$I_{SINK} = 20 \text{ mA}$ (low level < 0,8 V)

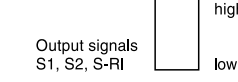

MSA 650

Scale model	System resolution	Accuracy grades *	Grating pitch (Edge separation a_{min}) *	Max. velocity
				continuous momentary

• **Square wave Line Driver signals with integrated Subdividing**

MSA 650.24	10 μm	$\pm 10 \mu\text{m/m}$	40 μm	1 m/s (5 μs)	2 m/s (2.5 μs)
MSA 650.23	5 μm	$\pm 5, \pm 10 \mu\text{m/m}$	20 μm	1 m/s (2.5 μs)	2 m/s (1.2 μs)
MSA 650.64	2 μm	$\pm 5, \pm 10 \mu\text{m/m}$	40 μm	1 m/s (800 ns)	2 m/s (400 ns)
MSA 650.63	1 μm	$\pm 5, \pm 10 \mu\text{m/m}$	20 μm	1 m/s (400 ns)	1 m/s (400 ns)
MSA 650.73	0.5 μm	$\pm 5, \pm 10 \mu\text{m/m}$	20 μm	1 m/s (200 ns)	1 m/s (200 ns)

* Other accuracy grades or grating pitches (e.g. Inch) upon request

Standard measuring lengths: (mm)

170, 220, 270, 320, 370, 420, 470, 520, 620, 720, 770, 820, 920, 1040, 1140, 1240, 1340, 1440, 1540, 1640, 1740

Measuring type: glass scale

Reference Mark (RI): selectable

MSA 650.xx **K**:

Distance coded Reference Marks (**K**): after travelling 20 mm the absolute position will be shown on the display.

MSA 650.xx:

Up to a measuring length of 920 mm, one Reference Mark can either be placed in the middle of scales 1040 mm or longer, or 35 mm from either end of measuring length. With a measuring length of 1040 mm or longer, a Reference Mark will be placed 45 mm from either end of the measured length.

Option:

One Reference Mark at any location, or two or more Reference Marks separated by distances of $n \times 50 \text{ mm}$

Required moving force:

with standard sealing lips < 3 N

with low drag sealing lips < 0.2 N

Environmental sealing DIN 40050:

IP 53 (with standard sealing lips)

Permissible vibration: 80 m/s^2 (40 to 2000 Hz)

Permissible shock: 200 m/s^2 (8 ms)

Permissible temperature:

-20°C to +70°C (storage), 0°C to +50°C (operation)

Weight (approx.):

0.8 kg/m (scale spar) + 85 g (scanning head without cable)

Signal-outputs (optional):

• **Square wave signals** (single ended)
with integrated Subdividing Electronics

• **Square wave signals** (differential)
via Line Driver RS 422 standard
with integrated Subdividing Electronics

MSA 650.23 = times1

MSA 650.24 = times1

MSA 650.63 = times5

MSA 650.64 = times5

MSA 650.73 = times10

Power supply:

+5 V $\pm 5\%$, < 150 mA (with interpolation, unloaded)
< 200 mA (without interpolation, unloaded)

MSA 651

Scale model	System resolution	Accuracy grades *	Grating pitch (Edge separation a_{min}) *	Max. velocity
				continuous momentary

• **Square wave Line Driver signals with integrated Subdividing**

MSA 651.24	10 μm	$\pm 10 \mu\text{m/m}$	40 μm	1 m/s (5 μs)	2 m/s (2.5 μs)
MSA 651.23	5 μm	$\pm 5, \pm 10 \mu\text{m/m}$	20 μm	1 m/s (2.5 μs)	2 m/s (1.2 μs)
MSA 651.64	2 μm	$\pm 5, \pm 10 \mu\text{m/m}$	40 μm	1 m/s (800 ns)	2 m/s (400 ns)
MSA 651.63	1 μm	$\pm 5, \pm 10 \mu\text{m/m}$	20 μm	1 m/s (400 ns)	1 m/s (400 ns)
MSA 651.73	0.5 μm	$\pm 5, \pm 10 \mu\text{m/m}$	20 μm	1 m/s (200 ns)	1 m/s (200 ns)

* Other accuracy grades or grating pitches (e.g. Inch) upon request

Standard measuring lengths: (mm)

170, 220, 270, 320, 370, 420, 470, 520, 620, 720, 770, 820, 920, 1040, 1140, 1240, 1340, 1440, 1540, 1640, 1740, 1840, 2040, 2240

Measuring type: glass scale

Reference Mark (RI): selectable

MSA 651.xx **K**:

Distance coded Reference Marks (**K**): after travelling 20 mm the absolute position will be shown on the display.

MSA 651.xx:

Up to a measuring length of 920 mm, one Reference Mark can either be placed in the middle of scales 1040 mm or longer, or 35 mm from either end of measuring length. With a measuring length of 1040 mm or longer, a Reference Mark will be placed 45 mm from either end of the measured length.

Option:

One Reference Mark at any location, or two or more Reference Marks separated by distances of $n \times 50 \text{ mm}$

Required moving force:

with standard sealing lips < 3 N

with low drag sealing lips < 0.2 N

Environmental sealing DIN 40050:

IP 53 (with standard sealing lips)

Permissible vibration: 80 m/s^2 (40 to 2000 Hz)

Permissible shock: 200 m/s^2 (8 ms)

Permissible temperature:

-20°C to +70°C (storage), 0°C to +50°C (operation)

Weight (approx.):

0.8 kg/m (scale spar) + 85 g (scanning head without cable)

Signal-outputs (optional):

• **Square wave signals** (single ended)
with integrated Subdividing Electronics

• **Square wave signals** (differential)
via Line Driver RS 422 standard
with integrated Subdividing Electronics

MSA 651.23 = times1

MSA 651.24 = times1

MSA 651.63 = times5

MSA 651.64 = times5

MSA 651.73 = times10

Power supply:

+5 V $\pm 5\%$, < 150 mA (with interpolation, unloaded)
< 200 mA (without interpolation, unloaded)

MSA 651 Dimensions - Mounting tolerances - Mounting possibilities:

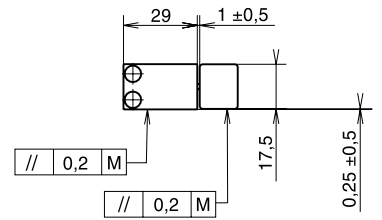
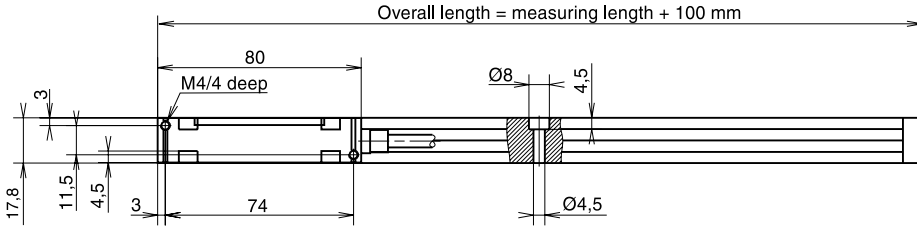
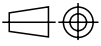

M = Machine guideway

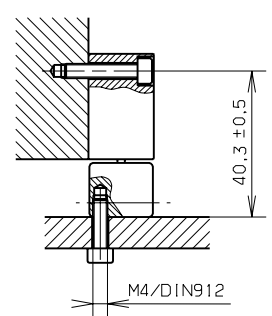
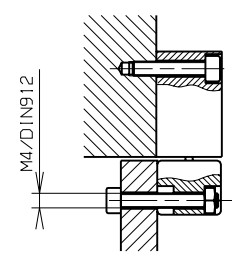
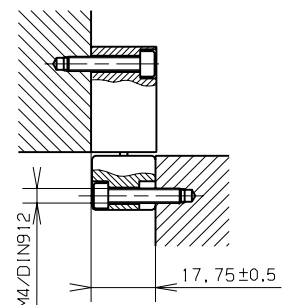
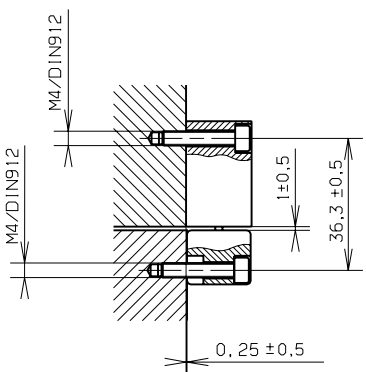
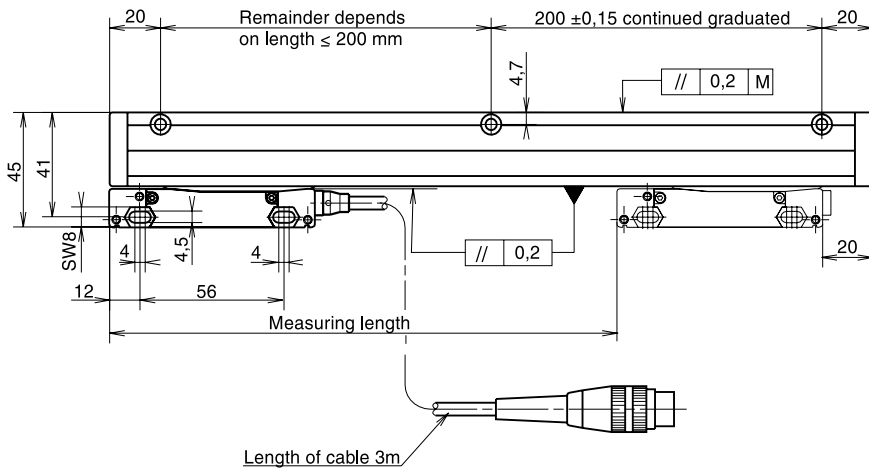

MSA 350

Scale model	System resolution	Accuracy grades *	Grating pitch * (Edge separation a_{min})	Max. velocity (continuous momentary)	
-------------	-------------------	-------------------	--	--------------------------------------	--

• **Square wave Line Driver signals with integrated Subdividing**

MSA 350.24	10 μm	$\pm 10 \mu\text{m/m}$	40 μm	1 m/s (5 μs)	2 m/s (2.5 μs)
MSA 350.23	5 μm	$\pm 5, \pm 10 \mu\text{m/m}$	20 μm	1 m/s (2.5 μs)	2 m/s (1.2 μs)
MSA 350.64	2 μm	$\pm 5, \pm 10 \mu\text{m/m}$	40 μm	1 m/s (800 ns)	2 m/s (400 ns)
MSA 350.63	1 μm	$\pm 5, \pm 10 \mu\text{m/m}$	20 μm	1 m/s (400 ns)	1 m/s (400 ns)
MSA 350.73	0.5 μm	$\pm 5, \pm 10 \mu\text{m/m}$	20 μm	1 m/s (200 ns)	1 m/s (200 ns)

* Other accuracy grades or grating pitches (e.g. Inch) upon request

Standard measuring lengths: (mm)

170, 220, 270, 320, 370, 420, 470, 520, 620, 720, 770, 820, 920, 1040, 1140, 1240, 1340, 1440, 1540, 1640, 1740, 1840, 2040, 2240 2440, 2640, 2840, 3040

Measuring type: glass scale

Reference Mark (RI): selectable

MSA 350.xx **K**:

Distance coded Reference Marks (**K**): after travelling 20 mm the absolute position will be shown on the display.

MSA 350.xx:

Up to a measuring length of 920 mm, one Reference Mark can either be placed in the middle of scales 1040 mm or longer, or 35 mm from either end of measuring length. With a measuring length of 1040 mm or longer, a Reference Mark will be placed 45 mm from either end of the measured length.

Option:

One Reference Mark at any location, or two or more Reference Marks separated by distances of $n \times 50 \text{ mm}$

Required moving force:

with standard sealing lips < 3 N

with low drag sealing lips < 0.2 N

Environmental sealing DIN 40050:

IP 53 (with standard sealing lips)

IP 64 with DA300 (DA300 see page 45)

Permissible vibration: 80 m/s^2 (40 to 2000 Hz)

Permissible shock: 200 m/s^2 (8 ms)

Permissible temperature:

-20°C to +70°C (storage), 0°C to +50°C (operation)

Weight (approx.)

3 kg/m (scale spar) + 180 g (scanning head without cable)

Signal-outputs (optional):

• **Square wave signals** (single ended)
with integrated **Subdividing Electronics**

• **Square wave signals** (differential)
via Line Driver **RS 422 standard**
with integrated **Subdividing Electronics**

MSA 350.23 = times1

MSA 350.24 = times1

MSA 350.63 = times5

MSA 350.64 = times5

MSA 350.73 = times10

Power supply:

+5 V $\pm 5\%$ < 150 mA (with interpolation, unloaded)
< 200 mA (without interpolation, unloaded)

MSA 350 Dimensions - Mounting tolerances - Mounting possibilities:

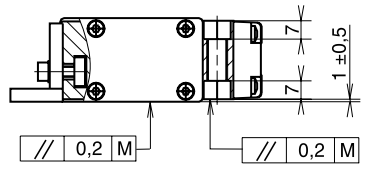
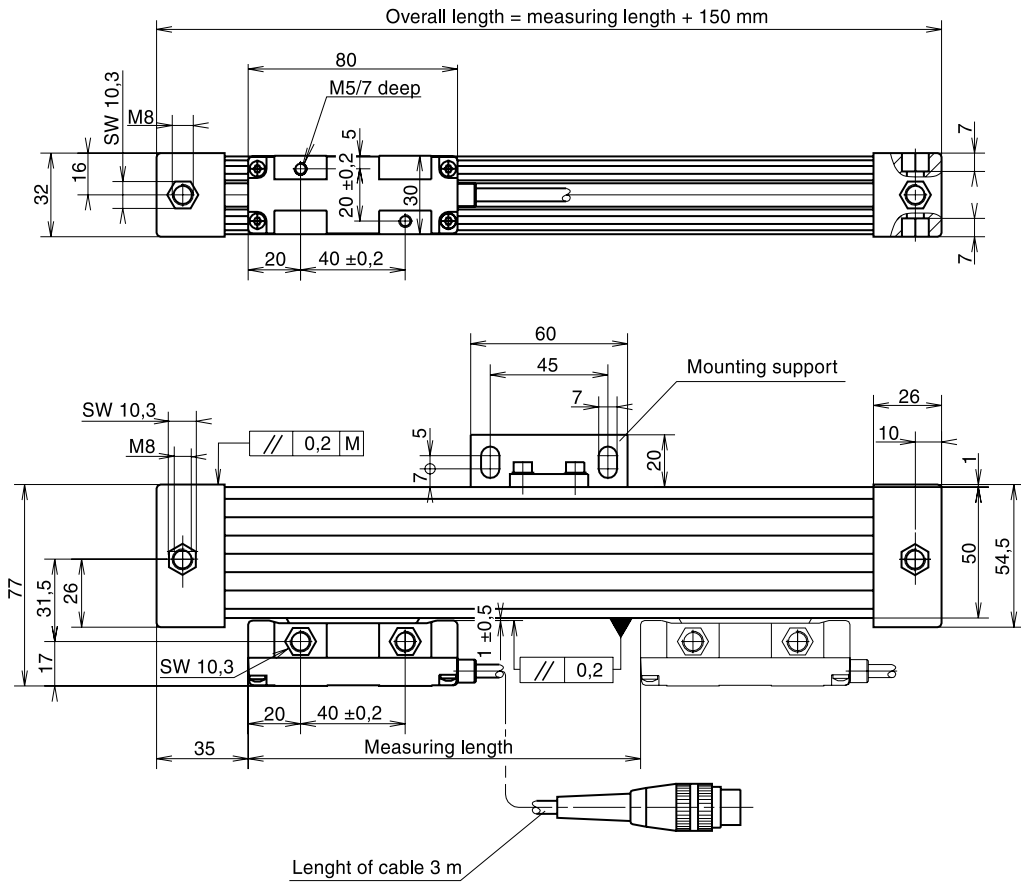
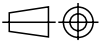

M = Machine guideway

quantity and position of the mounting support per measuring length

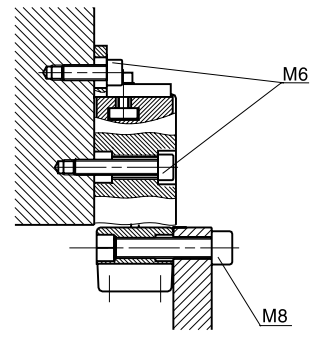
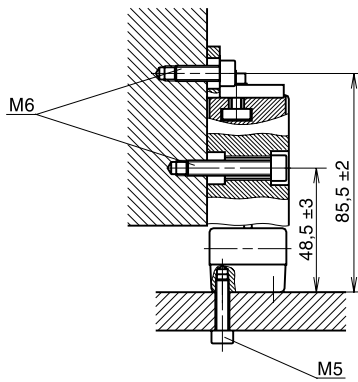
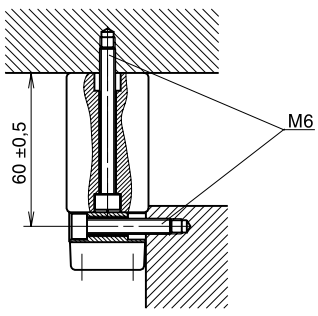
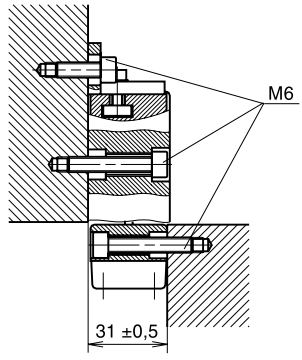
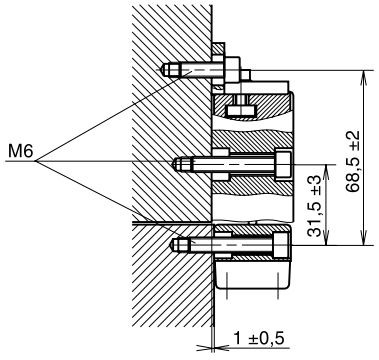
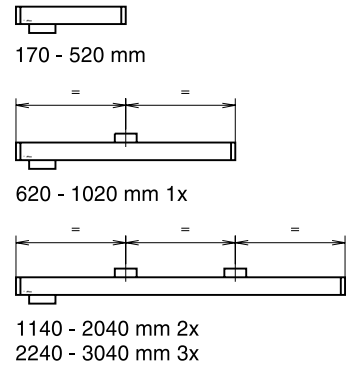

MSA 352

Scale model	System resolution	Accuracy grades *	Grating pitch (Edge separation a_{min}) *	Max. velocity continuous momentary	
-------------	-------------------	-------------------	--	---------------------------------------	--

• **Square wave Line Driver signals with integrated Subdividing**

MSA 352.24	10 μm	$\pm 10 \mu\text{m/m}$	40 μm	1 m/s (5 μs)	2 m/s (2.5 μs)
MSA 352.23	5 μm	$\pm 5, \pm 10 \mu\text{m/m}$	20 μm	1 m/s (2.5 μs)	2 m/s (1.2 μs)
MSA 352.64	2 μm	$\pm 5, \pm 10 \mu\text{m/m}$	40 μm	1 m/s (800 ns)	2 m/s (400 ns)
MSA 352.63	1 μm	$\pm 5, \pm 10 \mu\text{m/m}$	20 μm	1 m/s (400 ns)	1 m/s (400 ns)
MSA 352.73	0.5 μm	$\pm 5, \pm 10 \mu\text{m/m}$	20 μm	1 m/s (200 ns)	1 m/s (200 ns)

* Other accuracy grades or grating pitches (e.g. Inch) upon request

Standard measuring lengths: (mm)

170, 220, 270, 320, 370, 420, 470, 520, 620, 720, 770, 820, 920, 1040, 1140, 1240, 1340, 1440, 1540, 1640, 1740, 1840, 2040, 2240 2440, 2640, 2840, 3040

Measuring type: glass scale

Reference Mark (RI): selectable

MSA 352.xx **K**:

Distance coded Reference Marks (**K**): after travelling 20 mm the absolute position will be shown on the display.

MSA 352.xx:

Up to a measuring length of 920 mm, one Reference Mark can either be placed in the middle of scales 1040 mm or longer, or 35 mm from either end of measuring length. With a measuring length of 1040 mm or longer, a Reference Mark will be placed 45 mm from either end of the measured length.

Option:

One Reference Mark at any location, or two or more Reference Marks separated by distances of $n \times 50 \text{ mm}$

Required moving force:

< 6 N (two set of sealing lips)

Environmental sealing DIN 40050:

IP 54 (two set of sealing lips)

IP 64 with DA300 (DA300 see page 45)

Permissible vibration: 80 m/s^2 (40 to 2000 Hz)

Permissible shock: 200 m/s^2 (8 ms)

Permissible temperature:

-20°C to +70°C (storage), 0°C to +50°C (operation)

Weight (approx.):

3 kg/m (scale spar) + 180 g (scanning head without cable)

Signal-outputs (optional):

• **Square wave signals** (single ended)
with integrated Subdividing Electronics

• **Square wave signals** (differential)
via Line Driver RS 422 standard
with integrated Subdividing Electronics

MSA 352.23 = times1

MSA 352.24 = times1

MSA 352.63 = times5

MSA 352.64 = times5

MSA 352.73 = times10

Power supply:

+5 V $\pm 5\%$ < 150 mA (with interpolation, unloaded)

< 200 mA (without interpolation, unloaded)

MSA 352 Dimensions - Mounting tolerances - Mounting possibilities:

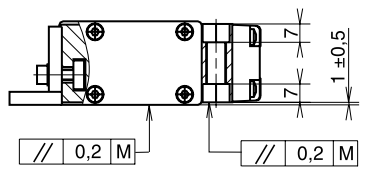
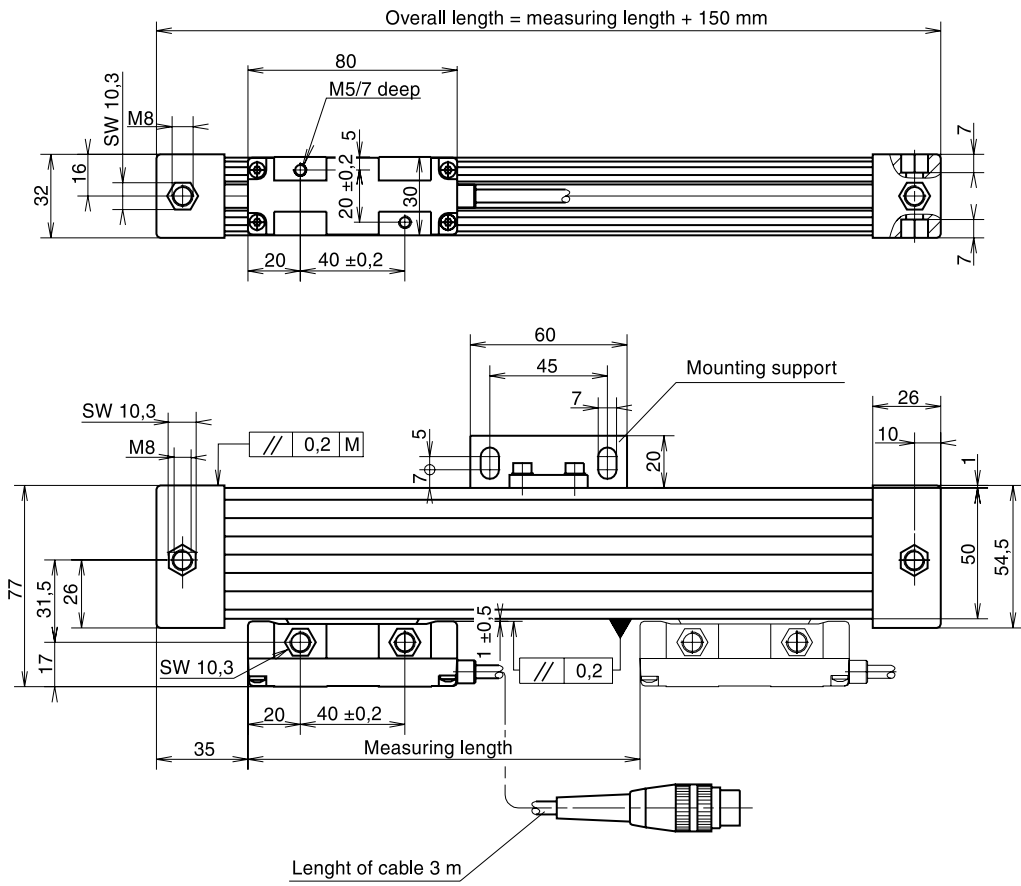
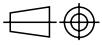

M = Machine guideway

quantity and position of the mounting support per measuring length

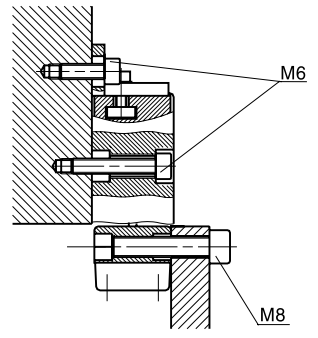
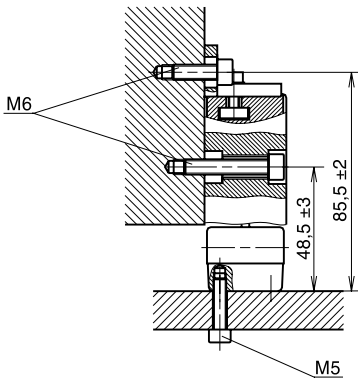
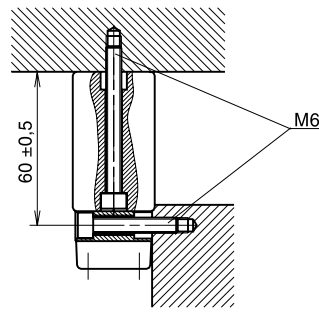
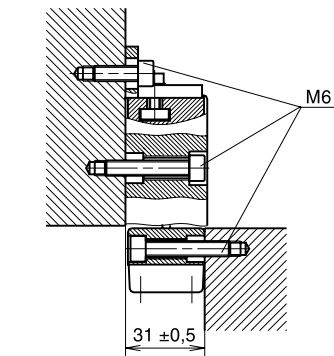
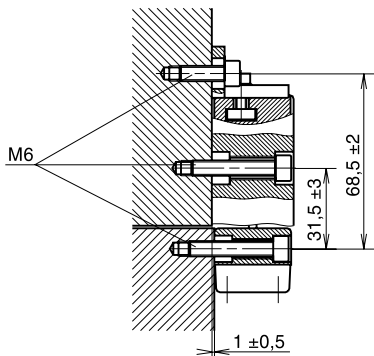
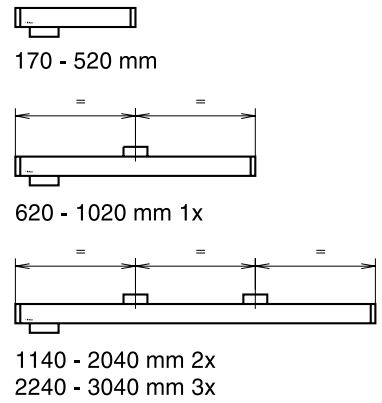

Subdividing Electronics ZE

ZE-xx Subdividing Electronic is available for applications where the Linear Encoder has a sinusoidal micro-current or sinusoidal voltage output. It is connected between the Linear Encoder and the Control or Digital Readout.

The ZE-xx divides the scale grating pitch to achieve finer resolutions and outputs square wave signals.

In addition, differential (complementary) Line Driver signals are output.

The Subdividing Electronic units are supplied in rugged housings, meeting the sealing requirements of IP 64.

ZE-Sx

- For Linear Encoders with sinusoidal voltage signals

ZE-Vx

- For Linear Encoders with sinusoidal micro-current signals

Interpolation:

ZE-S5, ZE-V5	=	times	5
ZE-S10, ZE-V10	=	times	10
ZE-S20, ZE-V20	=	times	20
ZE-S25, ZE-V25	=	times	25
ZE-S50, ZE-V50	=	times	50
ZE-S100, ZE-V100	=	times	100
ZE-S200, ZE-V200	=	times	200
ZE-S400, ZE-V400	=	times	400

Power supply: +5 V ±5%

Current consumption: 150 mA

(< 270 mA for ZE-S/V200 and ZE-S/V400)

- Linear Encoder not connected
- output signals loaded

Connectors:

(pin-outs and dimensions on page 44)

Input: chassis connector female

9-pin FB 91 (ZE-V) or 12-pin FB 121 (ZE-S)

Output: chassis connector male

12-pin FS 121 or 1 m cable with male connector 12-pin L121

Input signals ZE-Sx:

Encoder signals: sinusoidal voltage signals

0.6 to 1.2 V_{pp} (1V_{pp} typical)

with terminating impedance Z₀ = 120 Ω

Reference pulse: 0,2 to 0,85 V

0.2 to 0.85 V_{pp}

typical 0.4 V (useable component)

Input signals ZE-Vx:

Encoder signals: sinusoidal micro-current

signals 7 to 16 μA I_{pp} (11.5 μA typical)

Reference pulse: 2 to 8 μA I_{pp} (5 μA typical)

Max. input frequency:

ZE-S5, ZE-V5 = 100 kHz, a_{min} 300 ns

ZE-S10, ZE-V10 = 50 kHz, a_{min} 300 ns

ZE-S20, ZE-V20 = 56 kHz, a_{min} 200 ns

ZE-S25, ZE-V25 = 45 kHz, a_{min} 200 ns

ZE-S50, ZE-V50 = 45 kHz, a_{min} 100 ns

ZE-S100, ZE-V100 = 22.5 kHz, a_{min} 100 ns

ZE-S200, ZE-V200 = 10 kHz, a_{min} 100 ns

ZE-S400, ZE-V400 = 5 kHz, a_{min} 100 ns

Output signals:

Square wave signals + Reference pulse

via Line Driver RS 422 standard or single

ended phaseshift 90° el.

Dimensions::

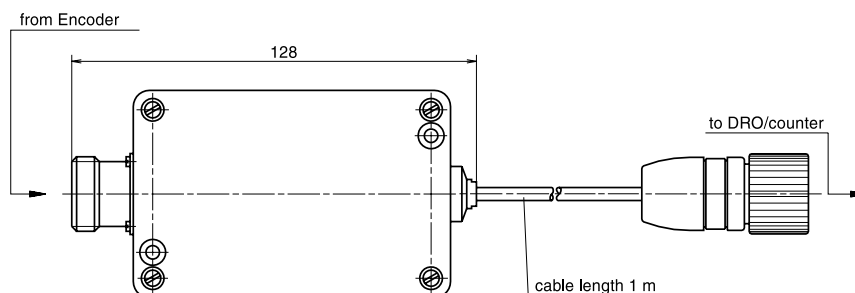
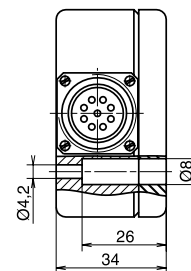
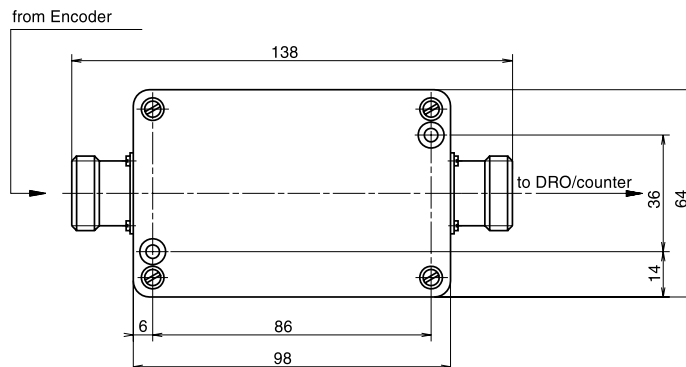
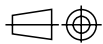

Interface Card IFC 430R

PC expansion board with PCI interface, serves to collect and evaluate encoder signals

Latch logic of the count values

- Asynchronous latch individually for each channel by software, encoder reference mark, or external signal
- Synchronous latch of several channels by software, timer, or external signal
- Output signal for cascading several cards; can be programmed for software sync or timer sync.

Counter operating modes

- Three counter channels (32 bits each) with one load and two latch registers
- Counting of encoder square-wave signals with one-fold, two-fold, or four-fold evaluation
- Event counter with direction and clear input
- Integral timer for measuring the pulse widths, the frequency, and the velocity.

PC bus

- PCI connector, 5 V, 32-bit, 2 x 60 pins
- Target interface (slave) for specifications Rev. 2.1
- Current consumption at +5 V approx. 0.5 A, without encoders
- Power supply of the encoders: +5 V or +12 V from PCI power supply (current consumption depends on encoders connected)

Counter interface (X1)

- Nine RS 422 or TTL inputs for three encoders with square-wave signals and reference mark
- Maximum input frequency 5 MHz with delta signals (Line Driver RS 422 standard) 2 MHz with single-end signals
- Perceives edge distances up to 80 ns
- One TTL input for interfering-signal monitoring
- Separate power supply lines for each encoder

I/O interface (X2)

- Six inputs (3 to 30 V) that can be used as reference pulse inhibitors or as asynchronous latch signals
- One input (3 to 30 V) for synchronous latch of several channels
- One output (TTL) for cascading several cards

Software

- DLL (Dynamic Link Library) for operation with Windows 95/98/ME and NT
- VxD driver for Windows 95/98/ME
- Sys driver for Windows NT
- Test and demo software with sample programs

Mechanical design and environment

- Dimensions (of the PCB) approx. 120 x 92 mm width = one slot
- Maximum permissible ambient temperature +40°C
- One D-sub female terminal strip, 25-pin for the counter inputs
- One D-sub female terminal strip, 9-pin for the for I/O-signals

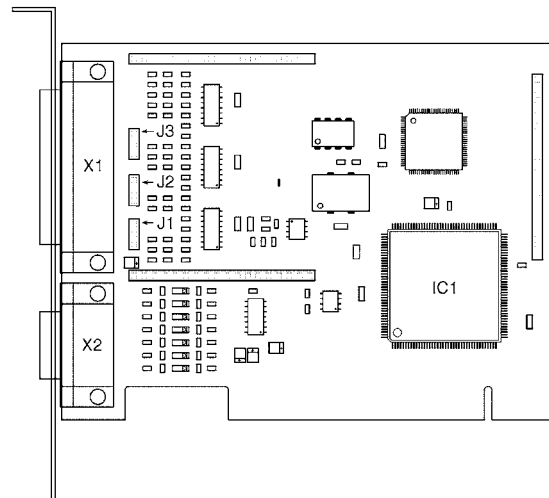

- X1 = female D-sub terminal strip, 25-pin for counter interface
- X2 = female D-sub terminal strip, 9-pin for switching and control signals
- J1-J3 = jumper for the selection of the encoder operating voltage (5 V or 12 V)
- IC1 = PCI interface

Block Diagram

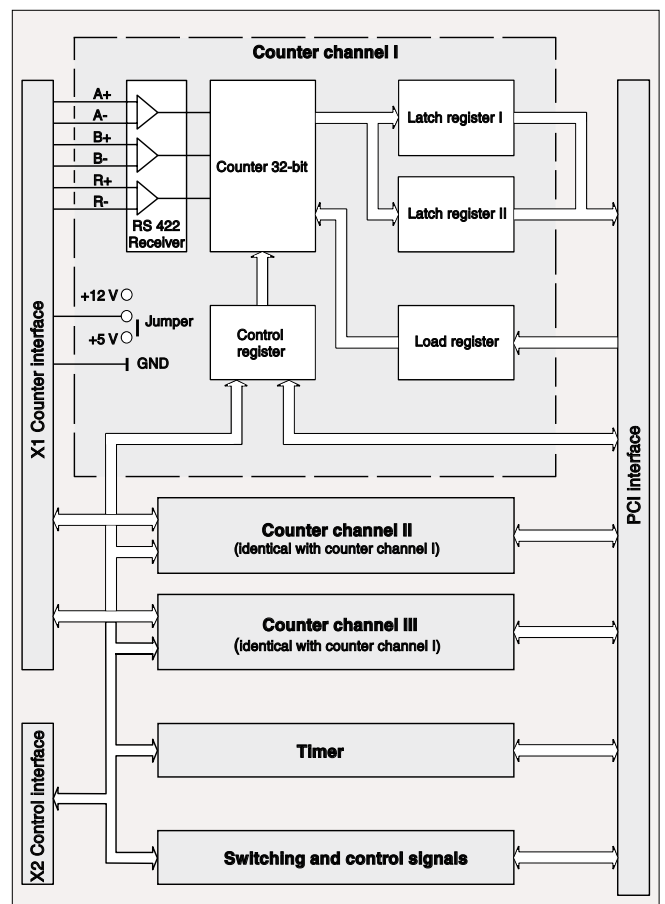

Connectors, pin-outs

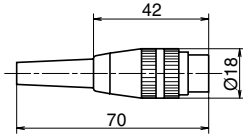
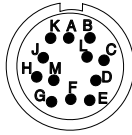
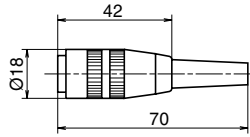
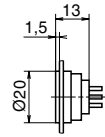
DIN **Male connector L 120**
12-pin

PIN outs connector
view on pins

Female connector K 120
12-pin

Female connector panel mountable F 120 12-pin

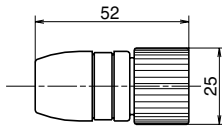
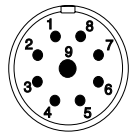
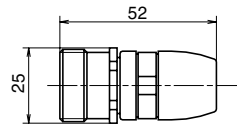
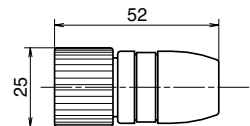
L120 PIN	A	B	C	D	E	F	G	H	J	K	L	M	
Voltage signals	inner shield	0 V	A1	$\overline{A1}$	A2	0 V	RI	\overline{RI}	0 V	+5 V	$\overline{A2}$	+5 V	(outer shield on chassis)

L120, K120, F120 PIN	A	B	C	D	E	F	G	H	J	K	L	M
Square wave signals + LD	shield*	GND	T1/0°	$\overline{T1/0°}$	T2/90°	GND	RI	\overline{RI}	GND	5 V	$\overline{T2/90°}$	5 V

* shield is on housing additional

CONNEI **Male connector L 91**
9-pin

PIN outs connector
view on pins

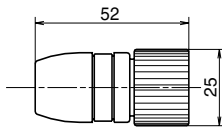
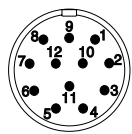
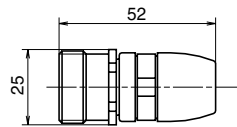
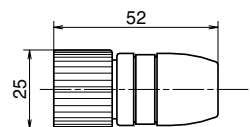
Female connector K 91
9-pin

Female connector KM 91
9-pin

L 91, K 91, KM 91 PIN	1	2	3	4	5	6	7	8	9	
Sinusoidal micro-current signals	0°+	0°-	5 V	0 V	90°+	90°-	RI+	RI-	inner shield	(outer shield on chassis)

CONNEI **Male connector L 121**
12-pin

PIN outs connector
view on pins

Female connector K121
12-pin

Female connector KM 121
12-pin

L 121 PIN	1	2	3	4	5	6	7	8	9	10	11	12	
Voltage signals	$\overline{A2}$	+5 V Sensor	RI	\overline{RI}	A1	$\overline{A1}$	+5 V	A2	inner shield	GND	GND Sensor	+5 V	(outer shield on chassis)

L121, K121, KM 121 PIN	1	2	3	4	5	6	7	8	9	10	11	12
Square wave signals + LD	$\overline{T2/90°}$	5 V	RI	\overline{RI}	T1/0°	$\overline{T1/0°}$	5 V	T2/90°	shield*	0 V	0 V	5 V

* shield is on housing additional

SUB MIN-D

LD 9 PIN	1	2	3	4	5	6	7	8	9
Square wave signals (single ended)	shield*	RI	T2	T1	+V	nc	nc	nc	GND

LD 9 PIN	1	2	3	4	5	6	7	8	9
Square wave signals (differential)	T1	$\overline{T1}$	T2	$\overline{T2}$	RI	\overline{RI}	+5 V	0 V	shield*

* shield is on housing additional

Male connector LD 9

9-pin

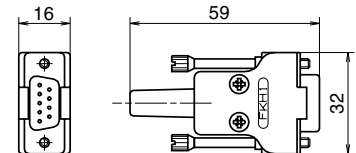
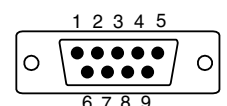

PIN outs connector
view on pins

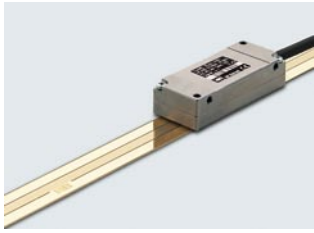
Other RSF-Products

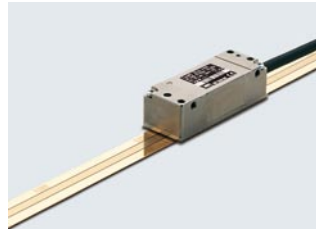

MS 20, MS 21 Reflective scanning Linear Encoder

- two independent switch signals for individual functions (MS 20)
- position of Reference Mark can be selected by the customer (MS 21)
- easy mounting as a result of large mounting tolerances
- high traversing speed
- high insensitivity to contamination
- integrated subdividing up to times 100 interpolation
- max. measuring length:
glass scale 3140 mm
steel tape scale 9440 mm



MS 30 Reflective scanning Linear Encoder

- two independent switch signals for individual functions
- easy mounting as a result of large mounting tolerances
- high traversing speed
- high insensitivity to contamination
- integrated subdividing up to times 100 interpolation
- max. measuring length 9440 mm

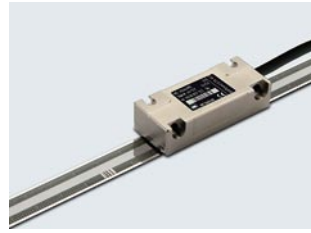

MS 40 Reflective scanning Linear Encoder

- with low price and high quality
- easy mounting as a result of large mounting tolerances
- high traversing speed
- high insensitivity to contamination
- integrated subdividing up to times 100 interpolation
- max. measuring length unlimited

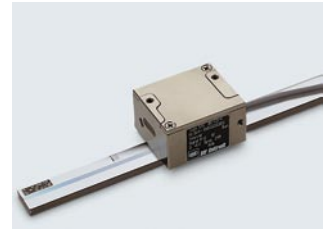

MS 8x Interferential Linear Encoder

- two switch tracks for individual special functions
- non-contact reflective scanning
- for high displacement velocities
- small dimensions
- scale versions: glass scale or ROBAX glassceramic with phase grating
- max. measuring length to 3240 mm



TDE 60 Two dimensional Encoder

- non-contact reflective scanning
- small dimensions
- scale version: glass scale
- measuring range 360 x 360 mm



DG 118, DG 120 Standard Rotary Encoder

- Rotary Encoder for universal application
- standard lines/rev. graduated from 100 to 5.400



DIT 10, DIT 30, DIT 48 Precision measuring Probes

- for universal applications
- stroke length 10, 30, 48 mm
- mounting on shaft sleeve
- mounting with two tapped holes on body (DIT 30, DIT 48)
- with cable lifter
- integrated pneumatic lifter optional
- sealing bellows optional (DIT 30, DIT 48)

Digital Readouts



Features:	Z 710	Z 720	Z 730	Z 715	Z 725	Z 735
						Z 735E ⁽¹⁾ Z 735S ⁽²⁾
number of axis	1	2	3	1	2	3
programming of system parameters		●			●	
selectable axis name		●			●	
switchable for use on a lathe or milling machine		●			●	
programmable resolution and counting direction		●			●	
Reset- and Preset input		●			●	
addition/subtraction with the keyboard		●			●	
bolt hole pattern, rectangular drilling pattern		●			●	
Reference mark evaluation (quasi-absolut)		●			●	
Hardware test and display test		●			●	
99 tool corrections (lathe mode)					●	
99 datum points (milling mode)					●	
store values for axis display		●			●	
absolute/incremental		●			●	
mm/inch conversion		●			●	
centering (divide by 2)		●			●	
radius/diameter		●			●	
adjustable for Rotary or Linear Encoder input.		●			●	
linear error correction programmable					●	
nonlinear axes-error correction					●	100 correction points
summing for two axis (Z + Z1)		●			●	
axes movements with displayed remaining travel way					●	
display for approximation to zero point		●			●	
feed display					●	
inbuilt stop-watch					●	
taper function					●	
display of spindle speed					●	
skew compensation					●	
Bi-directional RS 232 interface					○	
analog output					○	
free programmable switch off and pre-switch off points					○	
edge probe input					○	
external Reset for each axis					○	
external input					○	
output for constant surface speed					○	
special display for spark erosion					○	
compensation for grinding wheels					○	

(¹ = DRO for spark erosion machines, (² = DRO for surface grinders, ● = standard, ○ = optional with the additional price

Distribution contacts

Austria | RSF Elektronik Ges.m.b.H.
A-5121 Tarsdorf
☎ +43 (0) 6278 / 8192-0
☎ +43 (0) 6278 / 8192-79
e-mail: info@rsf.at
internet: www.rsf.at

USA | HEIDENHAIN CORPORATION
333 East State Parkway
Schaumburg, IL 60173-5337
☎ +1 847 490 - 1191
e-mail: info@heidenhain.com
internet: www.rsf.net

Switzerland | RSF Elektronik (Schweiz) AG
Mülistrasse 18
CH-8320 Fehraltorf
☎ +41 (0) 44 955 10 50
☎ +41 (0) 44 955 10 51
e-mail: info@rsf.ch
internet: www.rsf.ch

China | RSF Elektronik GmbH
Tian Wei San Jie,
Area A, Beijing Tianzhu Airport Industrial Zone
Shunyi District
101312 Beijing
P.R. China
☎ +86-10-8042-0288
☎ +86-10-8042-0290
e-mail: cao.shizhi@rsf.cn
internet: www.rsf.cn

Slovenia | RSF Elektronik prodaja, d.o.o.
Jozeta Jame 14
SI-1210 Ljubljana
☎ +386 1 519 88 80
☎ +386 1 519 88 80
e-mail: mail@rsf-elektronik.si

Korea | HEIDENHAIN LTD.
201 Namsung Plaza, 9th Ace Techno Tower,
345-30, Gasan-Dong, Geumcheon-Gu,
Seoul, Korea 153-782
☎ +82-2-2028-7430
e-mail: info@heidenhain.co.kr
internet: www.rsf.co.kr

Date 11/2008 • art.no. 386200-28 • techn. adjustment in reserve!



RSF Elektronik

Ges.m.b.H.

Precision Linear Scales
Digital Readouts
Industrial Electronics
Precision Graduations

certified according to
DIN EN ISO 9001
DIN EN ISO 14001

✉ **A-5121 Tarsdorf** • ☎ +43 (0)6278 / 8192-0 • ☎ +43 (0)6278 / 8192-79 • e-mail: info@rsf.at • internet: www.rsf.at