

# Introduction to Particle Physics

Physics 152/252

Lance Dixon

[lance@slac.stanford.edu](mailto:lance@slac.stanford.edu)

650-926-2627

<http://www.slac.stanford.edu/~lance/phys152>

(with special thanks to Colin Jessop)

18 Lectures - Mon, Wed 3:15-4:45pm

Room: 380-380X, Main Quad, under Mathematics

"Office Hours": after class

Lecture notes will be made available after lectures.  
Attendance required.

I'll switch between blackboard and electronic formats,  
depending on whether derivations or pictures & plots

TA: Marc Schreiber. [mschreib@stanford.edu](mailto:mschreib@stanford.edu)

**Problem Sets:** approx. 4 due (every 2 weeks).

**Class project:** short oral report around midterm week, on an experimental or theoretical paper of your choosing. I will give a list of possible papers later.

**Final Exam:** 1 week take home.

**Grading:** 50% problem sets 20% project  
30% final

# Course Goals

The course should give you a basic understanding of all the major concepts in particle physics, which are integrated into the **Standard Model**

We'll also cover some of the historical development of the subject, and experimental techniques used.

We'll conclude with a discussion of open questions - what remains to be understood?

# Course Text

David Griffiths, "Introduction to Elementary Particles"

Unfortunately, I only decided on this text last week, so you'll probably have to order it from e.g. Amazon. My apologies.

Some other references are available at the course web page, including:

Donald Perkins, "Introduction to High Energy Physics"  
(comprehensive, also discusses experimental techniques)

# Prerequisites

**Math:** Matrices, vectors, calculus, vector calculus  
(grad, div, curl)

**Physics:** Introductory Special Relativity, Intro  
Quantum Mechanics, Electromagnetism  
(Maxwell's equations).

I will review special relativity, QM and EM,  
but a basic familiarity is assumed.

# What is Particle Physics?

The ultimate reductionism - the breaking down of a problem into its smallest components.

In our case the problem is to elucidate the most fundamental structure of all matter and the interactions between those elements

We hope to find an underlying simplicity. A unifying set of principles that explains everything in the Universe. Our current state of knowledge is expressed in

The Standard Model of Particle Physics

# Atoms and the Nucleus

All atoms are made of **electrons**, **protons** and **neutrons**.

Are **electrons**, **protons** and **neutrons** made of something smaller ?

What stops Coulomb repulsion from destroying the nucleus ?

Helium Atom

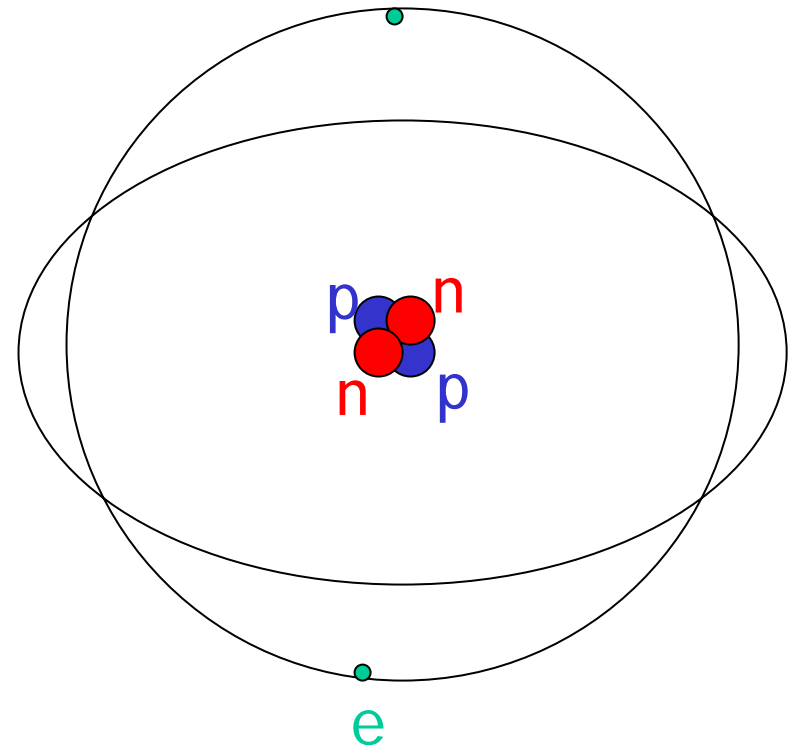

# Quarks and Leptons

## Nucleons are made of Quarks

- "up" quark charge= $+2/3$
- "down" quark charge= $-1/3$

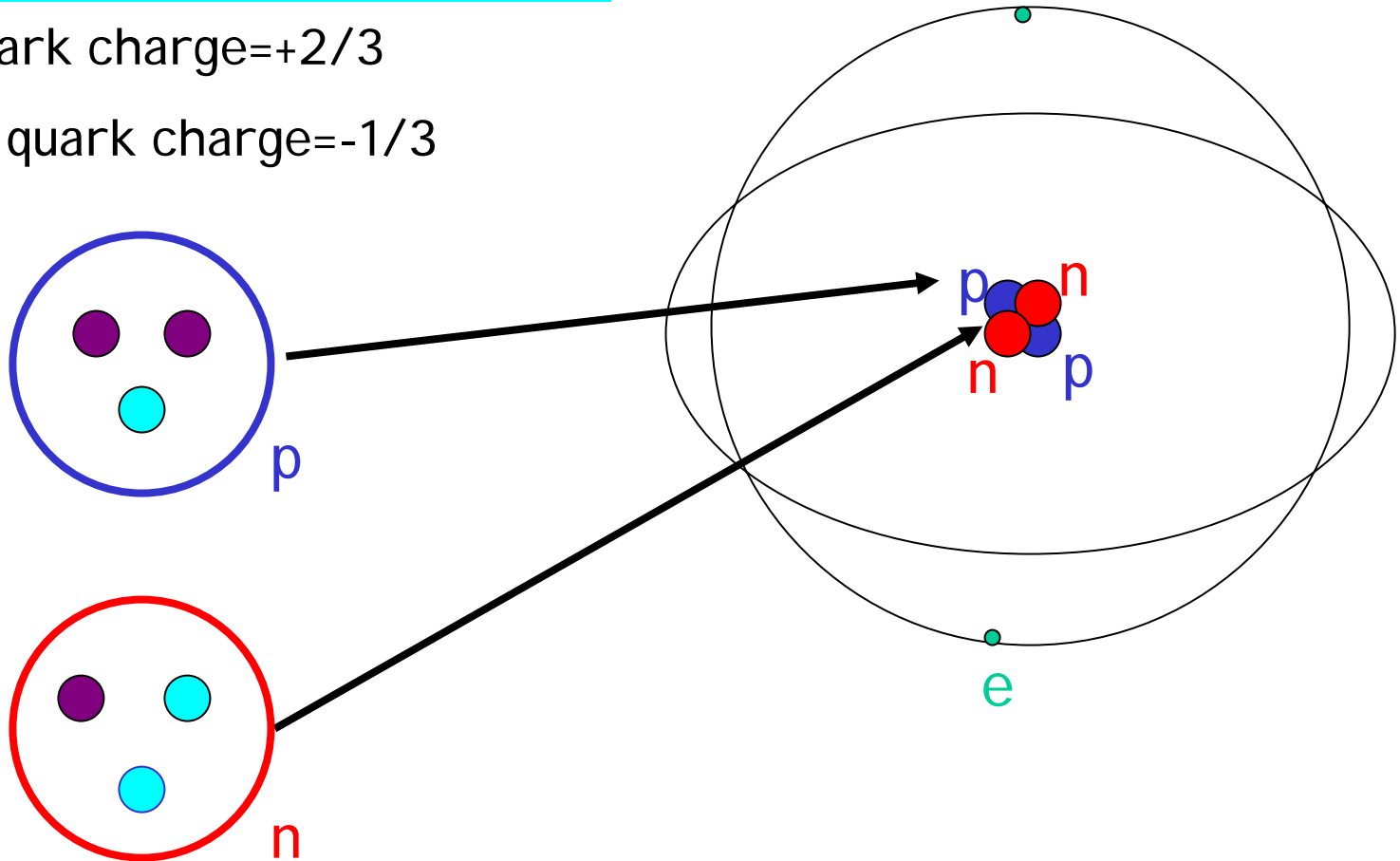

Electrons are fundamental (as far as we know). They are part of a family of particles called leptons.

# Discovery of Quarks



Quarks  
discovered  
here

High Energy (2 miles of acceleration) Electron Beam  
used for this experiment

# High Energy to see Quarks

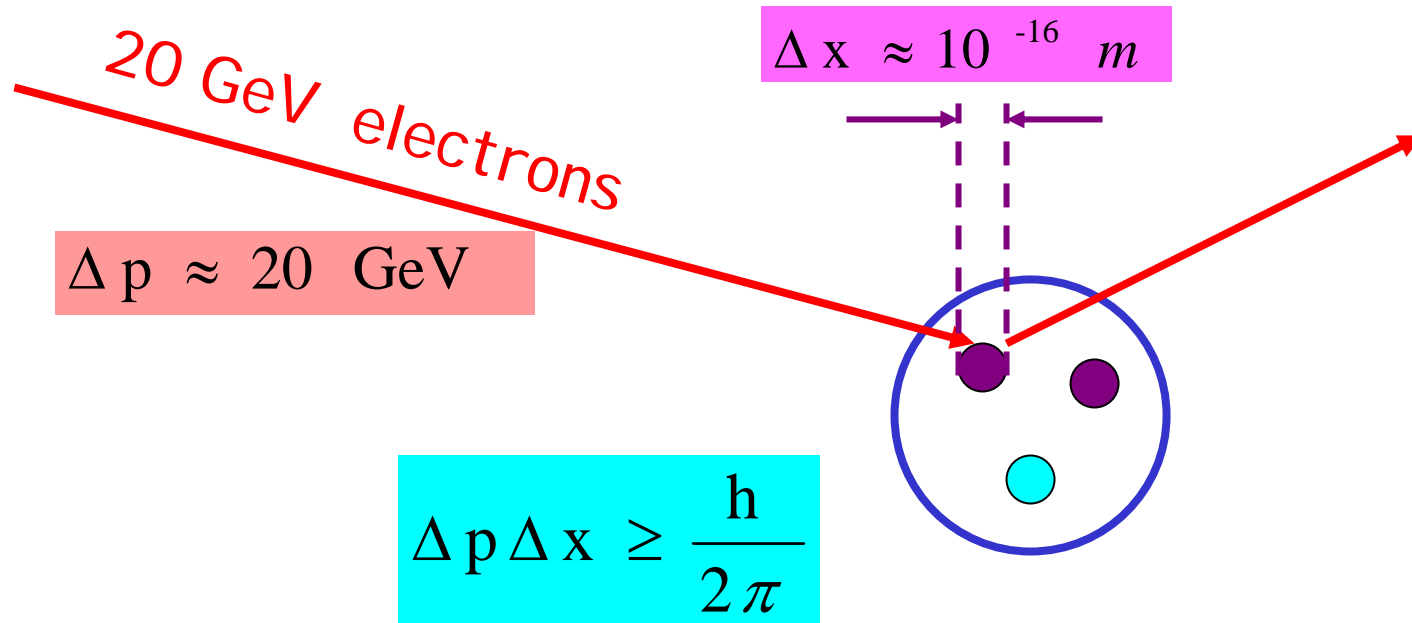

Observed by high energy “Rutherford Scattering”  
Need momentum transfer of  $\Delta p$  to resolve structure  
at  $\Delta x$  scales. Particle physics also called high energy  
physics for this reason.

# Particle Accelerators

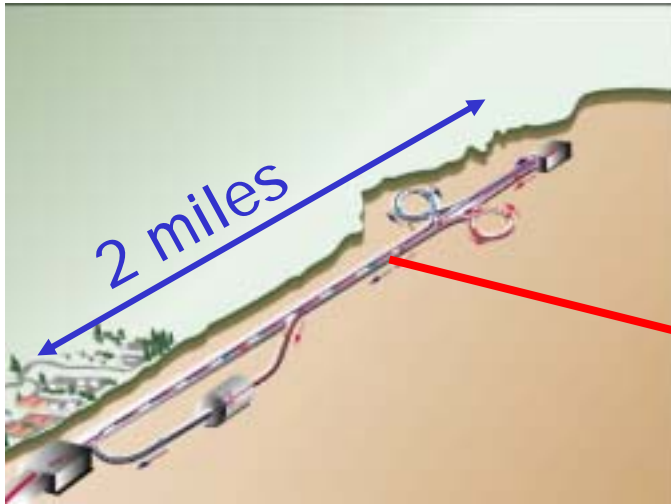

20 GeV =  $2 \times 10^{10}$  eV

Like 20 million TV's back to back



ACC\_01

PEP-II Accelerator at SLAC

8-19-97

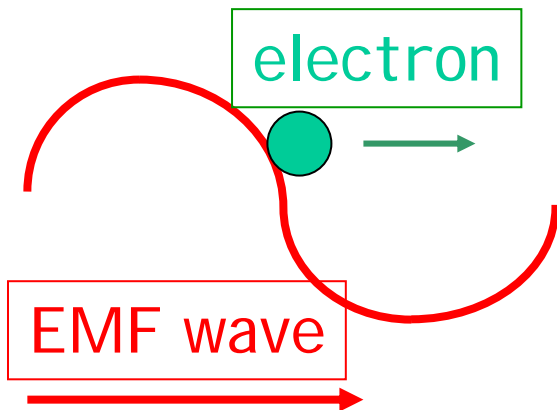

# Particle Experiments

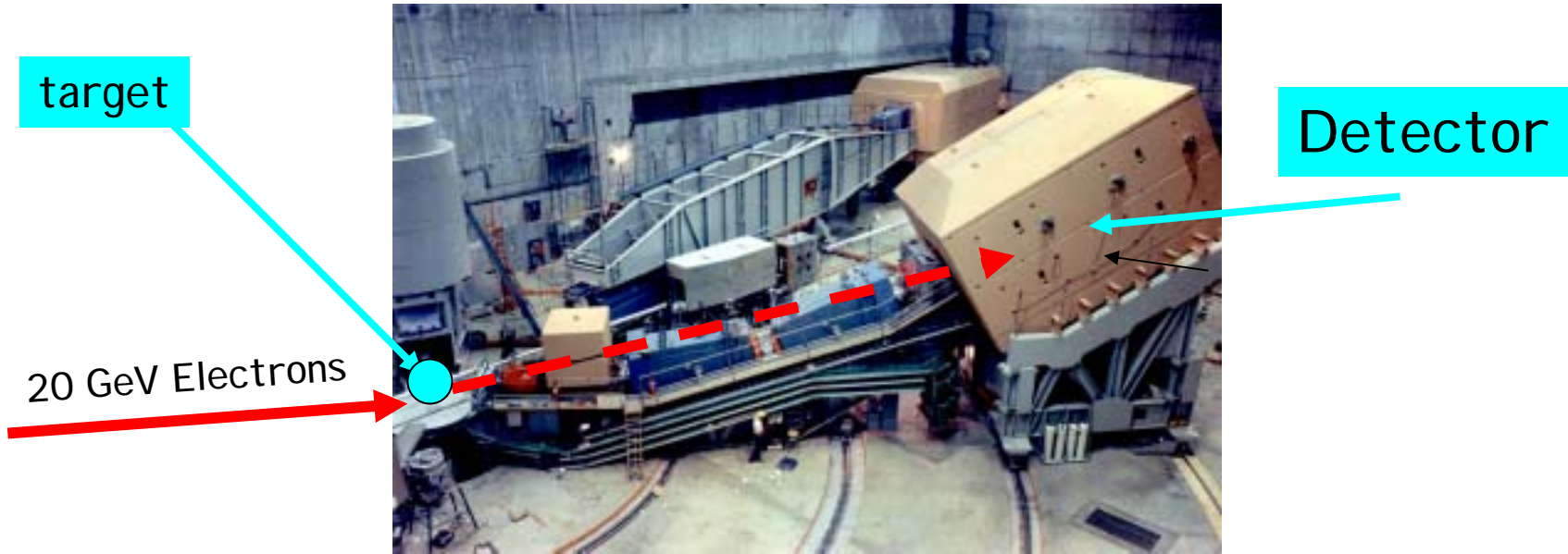

A detector is a set of different devices that measure the momentum, energy, charge and mass of the particles emerging from the collision

# Particle Interactions

Relativistic Quantum Field Theory describes particle interactions.

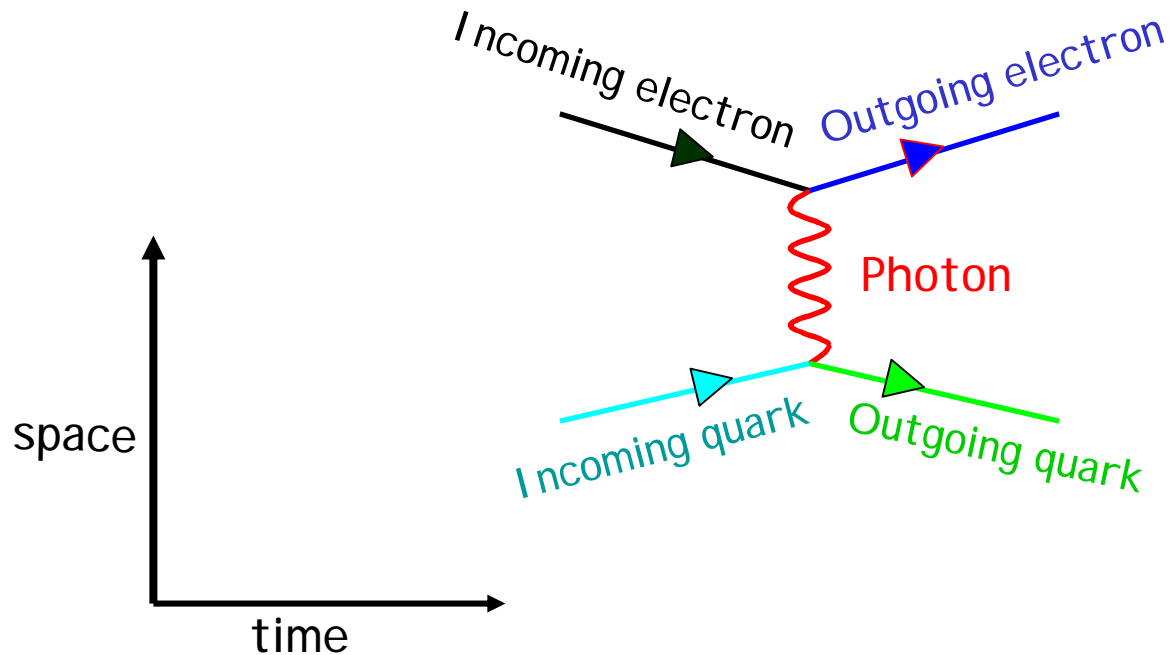

The electron and quark interact electromagnetically by the exchange of a photon

# Particle Interactions

A particle is a quantum excitation of a field

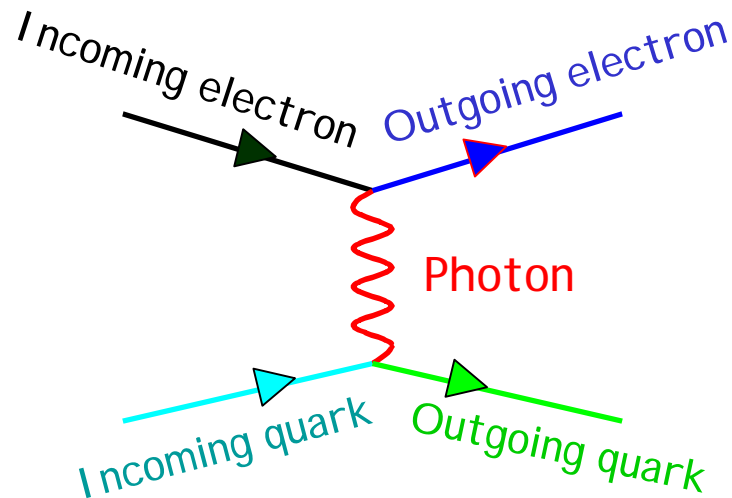

At the “vertices” the incoming electron/quark is annihilated, the photon created/annihilated, and the outgoing electron quark is created. The photon “propagates” the force.

# Particle Interactions

These are called "Feynman Diagrams"

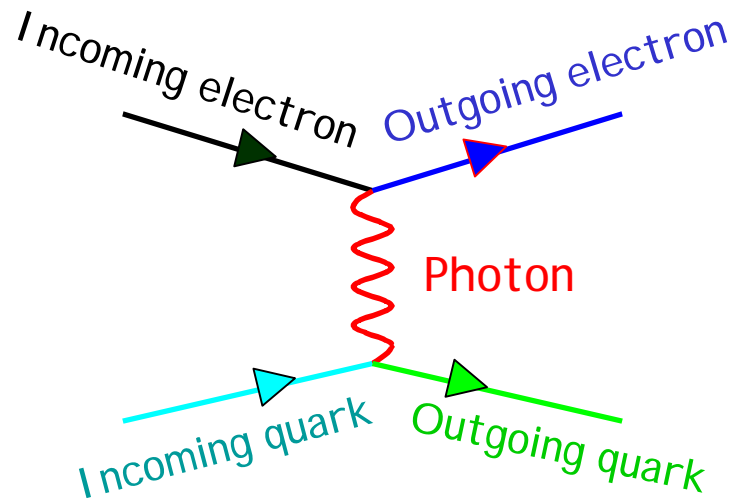

They are mathematical mnemonics. Each vertex and line represents a term in the expression for the quantum mechanical transition amplitude for the scattering

# Particle Interactions

A goal of the course is that you be able to understand these diagrams and be able to calculate a simple one

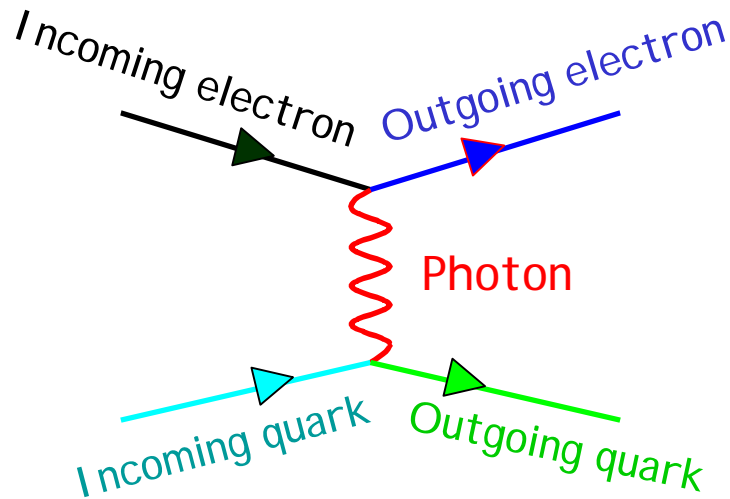

# Quarks and Leptons

Matter is made of fermions (spin 1/2) (quarks and leptons (e.g electron)) which interact by exchange of gauge bosons (spin 1) (e.g photons).

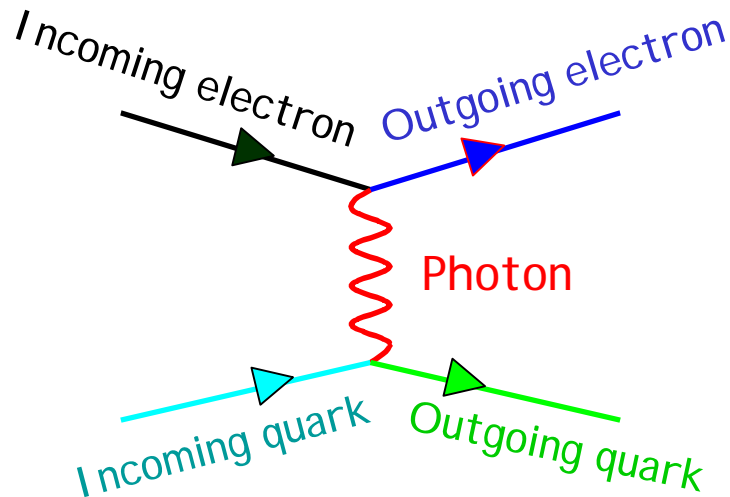

This is the electromagnetic interaction but there are other types of interaction

# The Four Forces

Force	Boson	Lepton	Quark	Strength
Strong	Gluon	No	Yes	1
Electro-magnetic	Photon	Yes	Yes	$10^{-2}$
Weak	$W^+, W^-, Z^0$	Yes	Yes	$10^{-7}$
Gravity	Graviton	Yes	Yes	$10^{-39}$

# The Electromagnetic Force

The theory of the electromagnetic force is called Quantum Electrodynamics (QED)

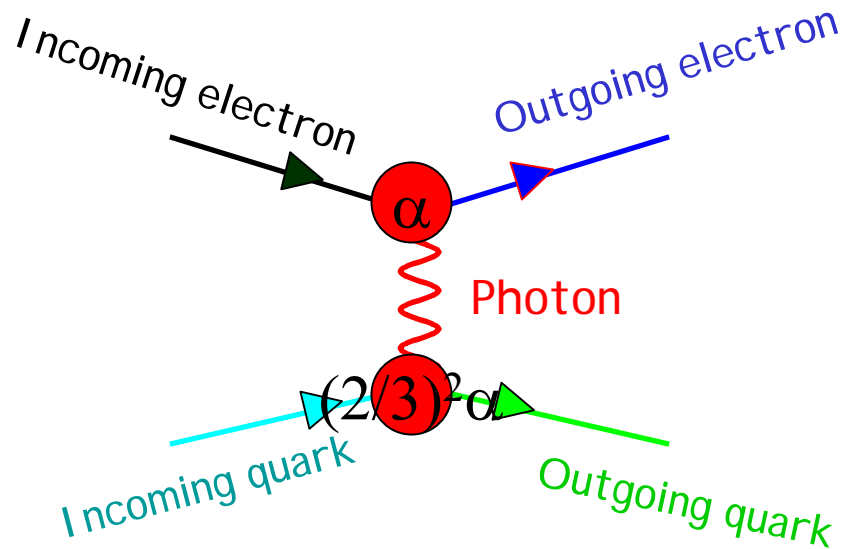

The photon “couples” to charge with strength  $\alpha = e^2/4\pi$ . The force is also proportional to the particle’s charge  $Q$ . It gets smaller as the electron and quark get further apart, like  $1/r^2$  (Coulomb’s Law).

# The Strong Force

The theory of the strong interaction is called Quantum Chromo Dynamics (QCD)

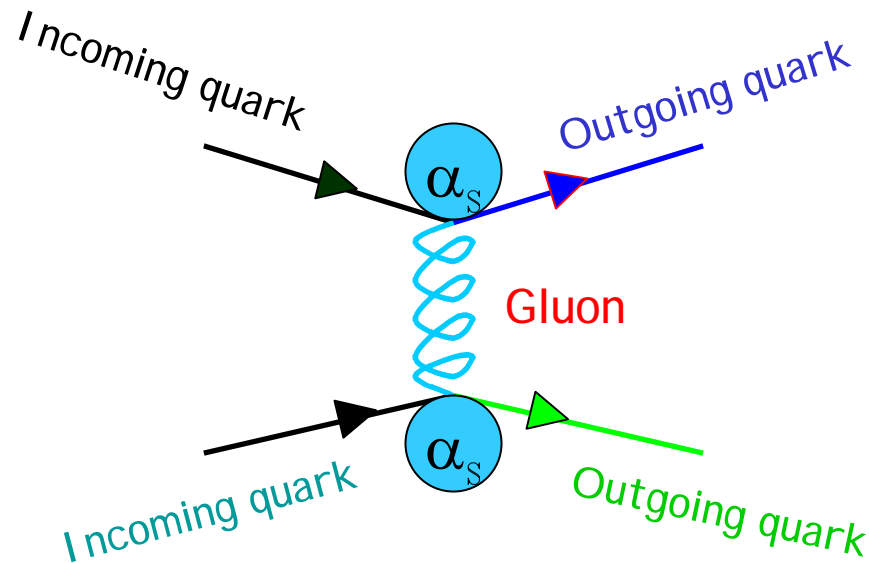

The gluon couples to "color charge" with strength  $\alpha_s$ . However there are three types of charge: red, blue and green. Also the force becomes a constant (like a rubber band) as the quarks get far apart! The strong force holds the nucleus together.

# The Weak Neutral Force

Quarks and leptons can couple “weakly” through the neutral Z boson

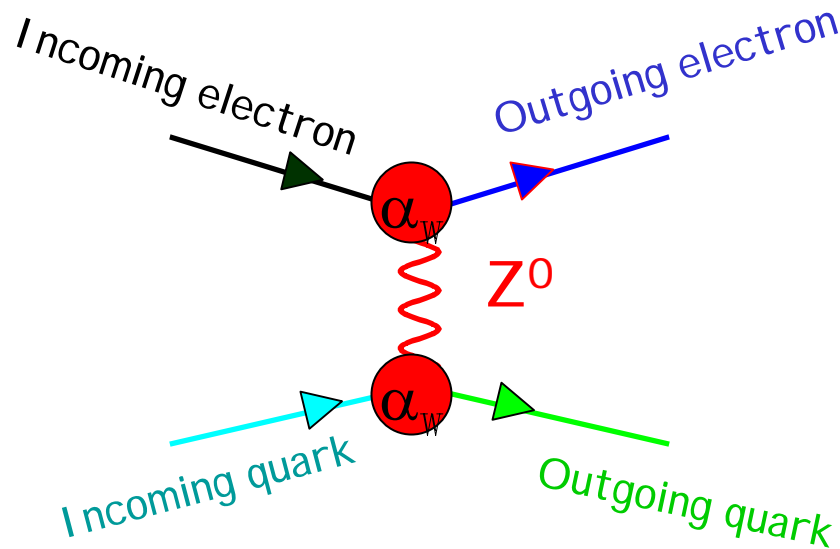

The Z boson couples to quarks and leptons with strength  $\alpha_W = e \cdot f(\sin \theta_W)$ . The function  $f$  is different for quarks and leptons. The Z boson has a mass of 90 GeV (90 times the proton mass!) which accounts for the weakness of the force. The weak force is closely related to the electromagnetic force.

# The Weak Charged Force

Quarks and leptons also couple “weakly” through the charged  $W^+$  and  $W^-$  bosons

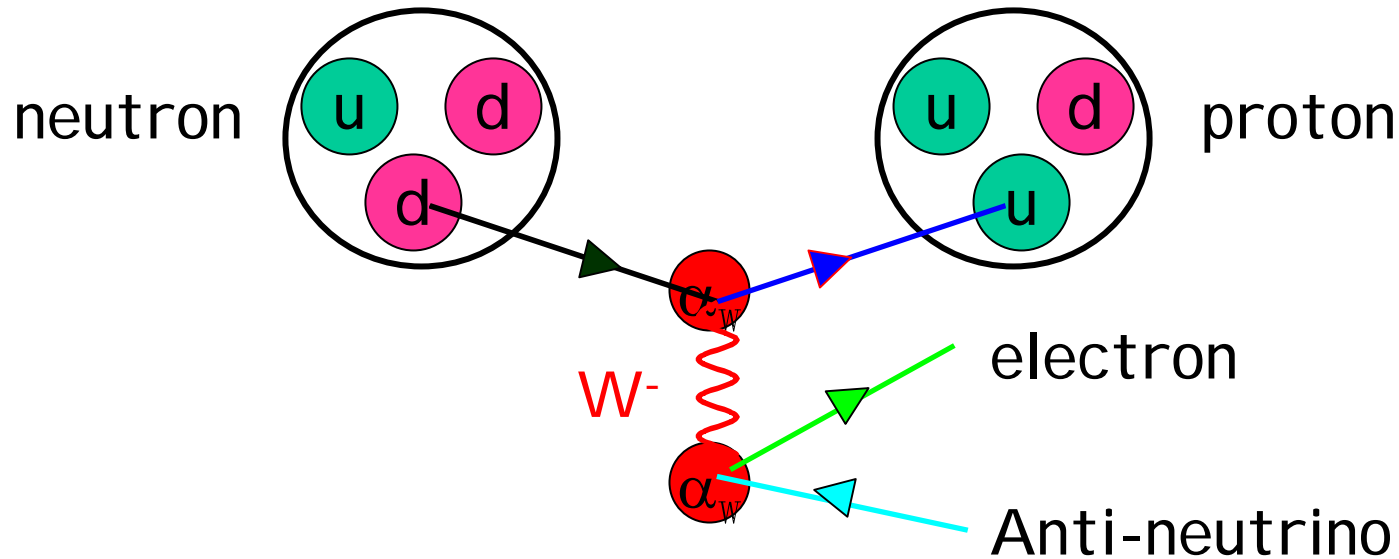

The weak charged force can turn a down quark into an up quark. It is responsible for radioactive decay (e.g. beta decay as above). Like the weak neutral force it is closely related to the electromagnetic force.

# The Neutrino

The neutrino only couples “weakly”. In the charged weak decays it is associated with the electron.

$$\begin{pmatrix} e \\ \nu_e \end{pmatrix}$$

The neutrino is a neutral lepton with spin 1/2. Until recently it was believed to be massless. Recently it was discovered that it has a very small mass - a significant result with profound implications for cosmology as well as particle physics. Because of its weak interaction it is very difficult to detect directly.

# A Neutrino Mass Experiment

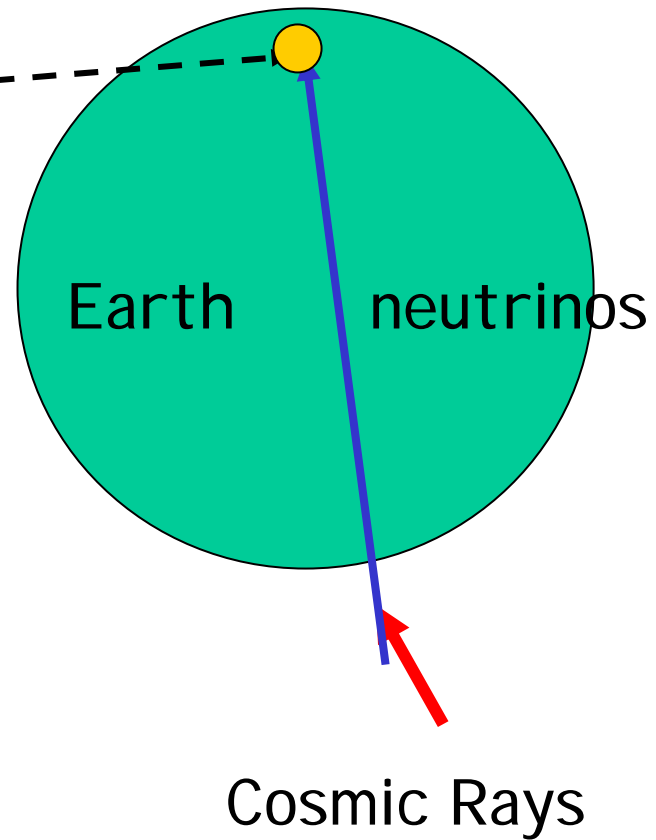

The SuperKamiokande experiment in a mine in Japan is a giant water tank designed to detect electrons from neutrino interactions

# Antimatter

The combination of special relativity and Quantum Mechanics leads to a new entity - antimatter

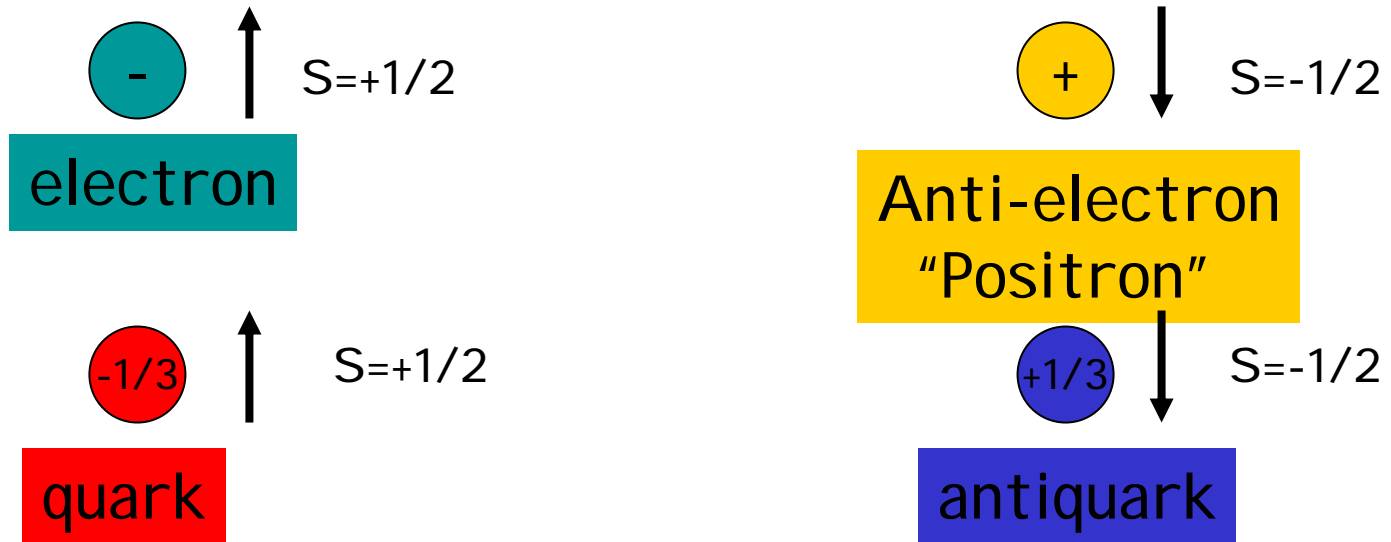

Anti-electron/quark has opposite charge to electron/quark but the same mass.

# AntiMatter

Matter and antimatter is created/annihilated in pairs

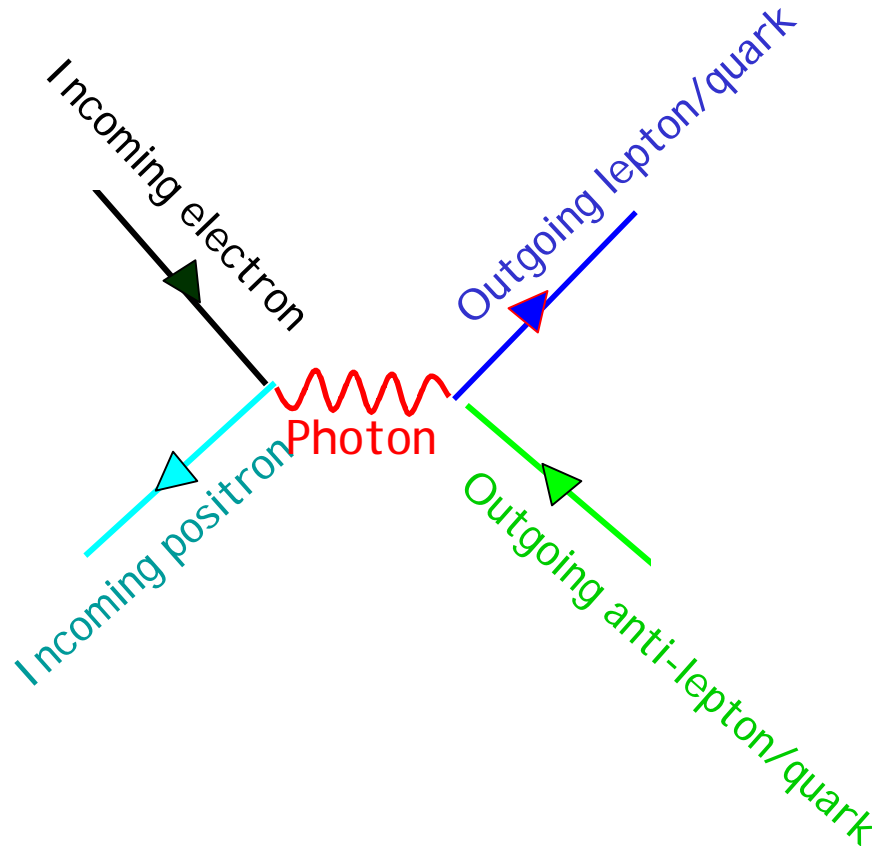

We can collide matter with antimatter to make other matter/antimatter pairs

# Matter-Antimatter Collisions

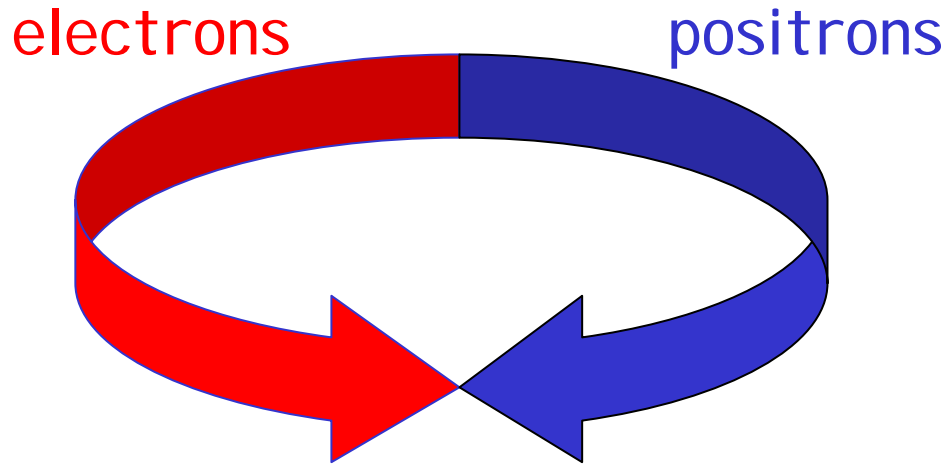

SPEAR at SLAC

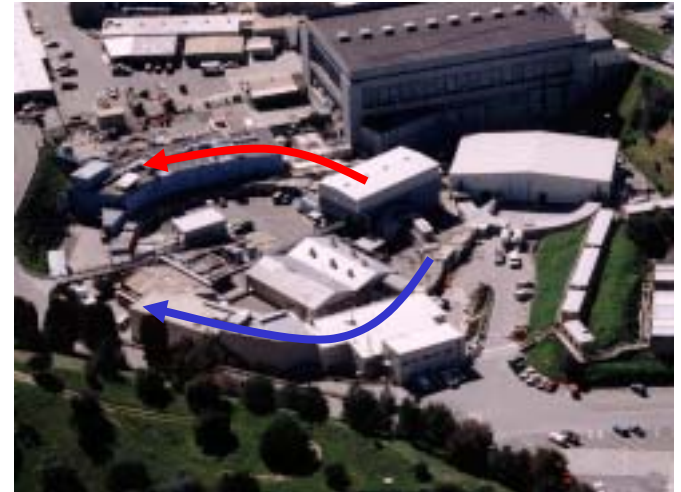

Can collide electrons and positrons in storage rings (invented at Stanford). Example of a collider experiment.

# Matter-AntiMatter Collisions

The Universe evolved from the Big Bang

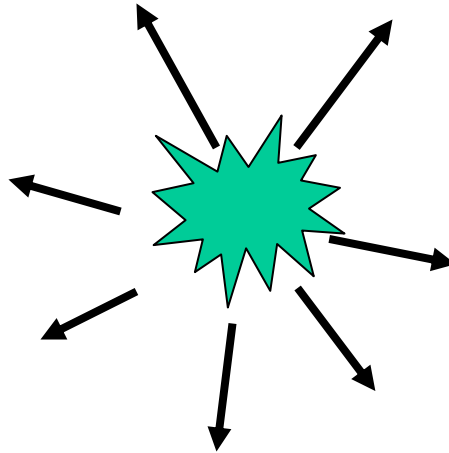

Creating a packet of pure energy replicates the conditions at  $10^{-9}$ - $10^{-12}$  s after creation (we are now at  $10^{18}$  s). Understanding these particle physics at these high energies helps understand how the universe evolved from these early times.

# 3 Generations of Leptons

	electron	muon	tau
Mass (GeV)	0.00051	.105	1.777
	$\begin{pmatrix} e \\ \nu_e \end{pmatrix}$	$\begin{pmatrix} \mu \\ \nu_\mu \end{pmatrix}$	$\begin{pmatrix} \tau \\ \nu_\tau \end{pmatrix}$
Mass (GeV)	?	$10^{-11}?$	$10^{-10}?$

The second and third generations couple exactly the same as first (electron). Neutrino mass (and mixing) is a current research topic of great interest.

# The Muon

In nature a flux of muons is produced by the interaction of cosmic rays with the atmosphere

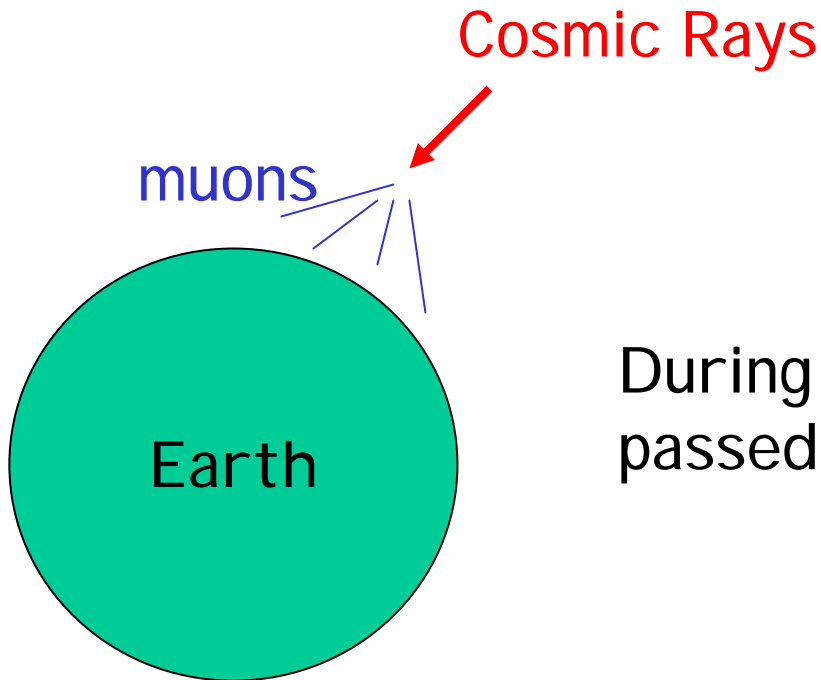

Flux =  $1 \text{ cm}^{-2} \text{ s}^{-1}$  at surface

During this lecture 200,000 have passed through your hand

Muons can interact to cause alterations in genetic material - source of mutations

# The Tau

Discovered at Stanford in e+e- collisions

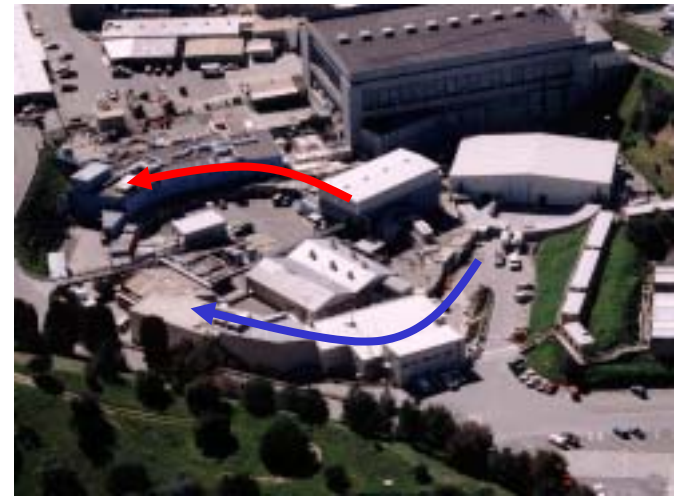

The tau can decay weakly to leptons and quarks

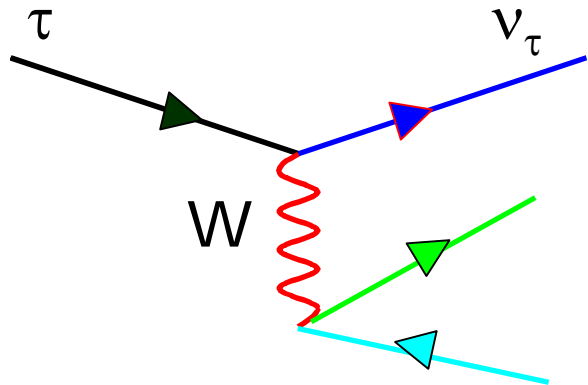

$$\tau^+ \rightarrow \pi^+ \pi^- \pi^+ \pi^- \pi^+ \bar{\nu}_\tau$$

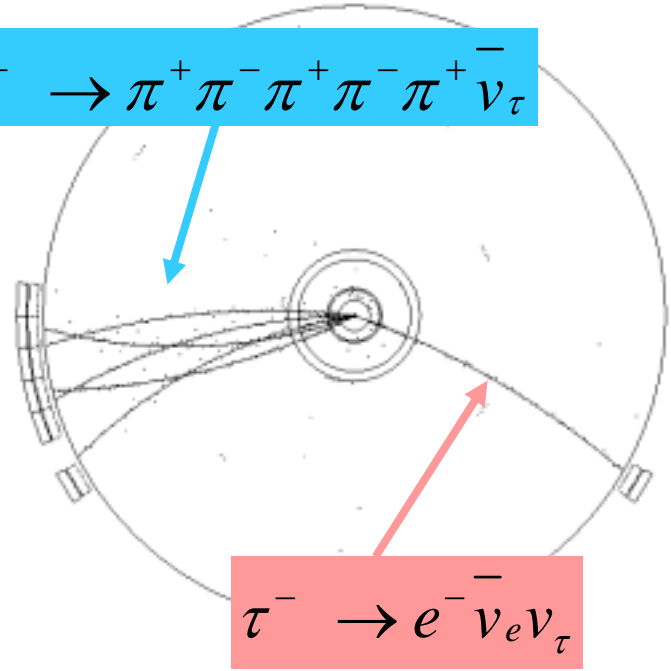

$$\tau^- \rightarrow e^- \bar{\nu}_e \nu_\tau$$

# 3 Generations of Quarks

Mass (GeV)	0.0025	1.2	176
	$\begin{pmatrix} up \\ down \end{pmatrix}$	$\begin{pmatrix} charm \\ strange \end{pmatrix}$	$\begin{pmatrix} truth \\ beauty \end{pmatrix}$
Mass (GeV)	0.0050	0.135	5.3

The second and third generations couple exactly the same as first. The third generation is the subject of great interest right now.

# Hadrons

Quarks only exist in "color neutral" combinations

blue - antiblue  
green - antigreen  
red - antired

red-green-blue

Baryons (e.g. proton)

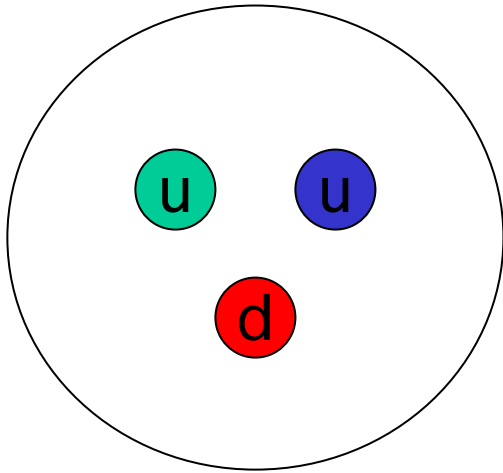

Mesons (e.g.  $\pi$ )

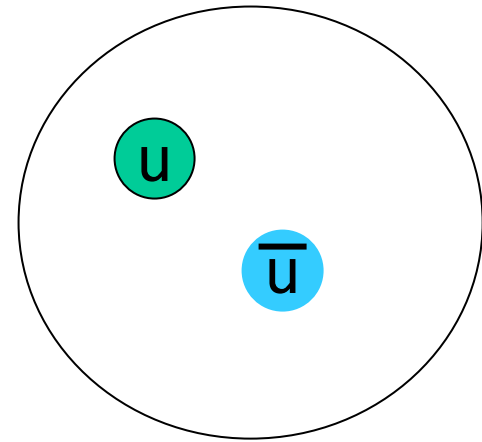

# Hadrons

There are hundreds of baryons and mesons. See the online "Particle Data Book" for the full list

<http://www.pdg-lbl.gov>

Charmonium (charm-anticharm)

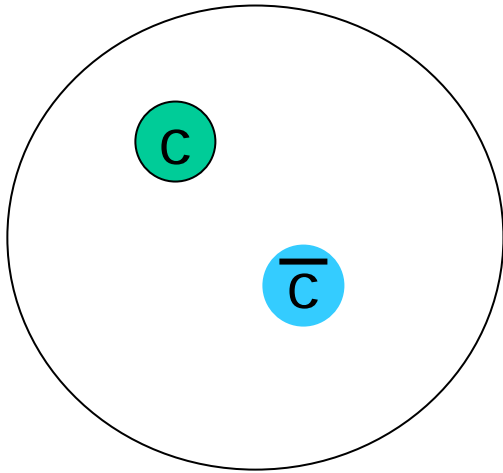

Upsilon (beauty-antibeauty)

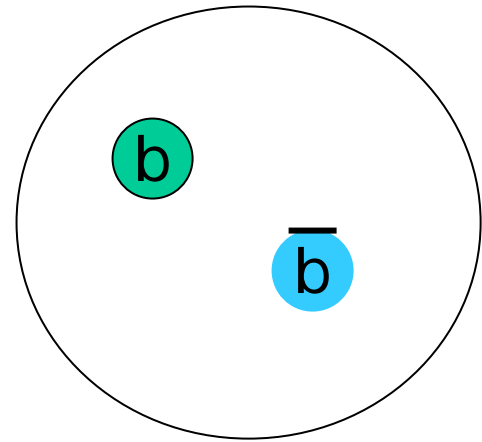

# The charm quark

Discovered at Stanford in  $e^+e^-$  collisions  
(and at Brookhaven, NY in  $p$  Be collisions  
at exactly the same time, Nov. 1974)

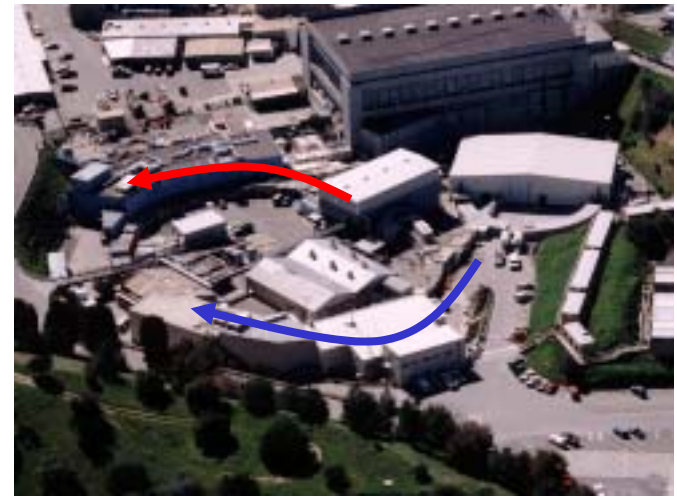

The charm-anticharm meson  
decays shortly after production

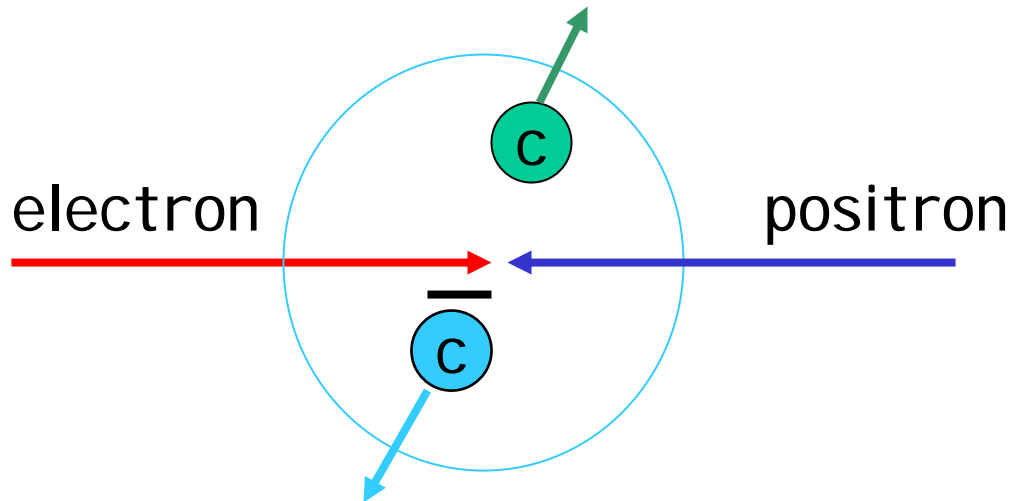

# The beauty quark

Currently we are producing millions of beauty -antibeauty quarks at Stanford in  $e^+e^-$  collisions, in the form of B and anti-B mesons (hence the name of the detector, BaBar). Small differences between B and anti-B decays may help us understand why there is a matter-antimatter asymmetry in the universe today.

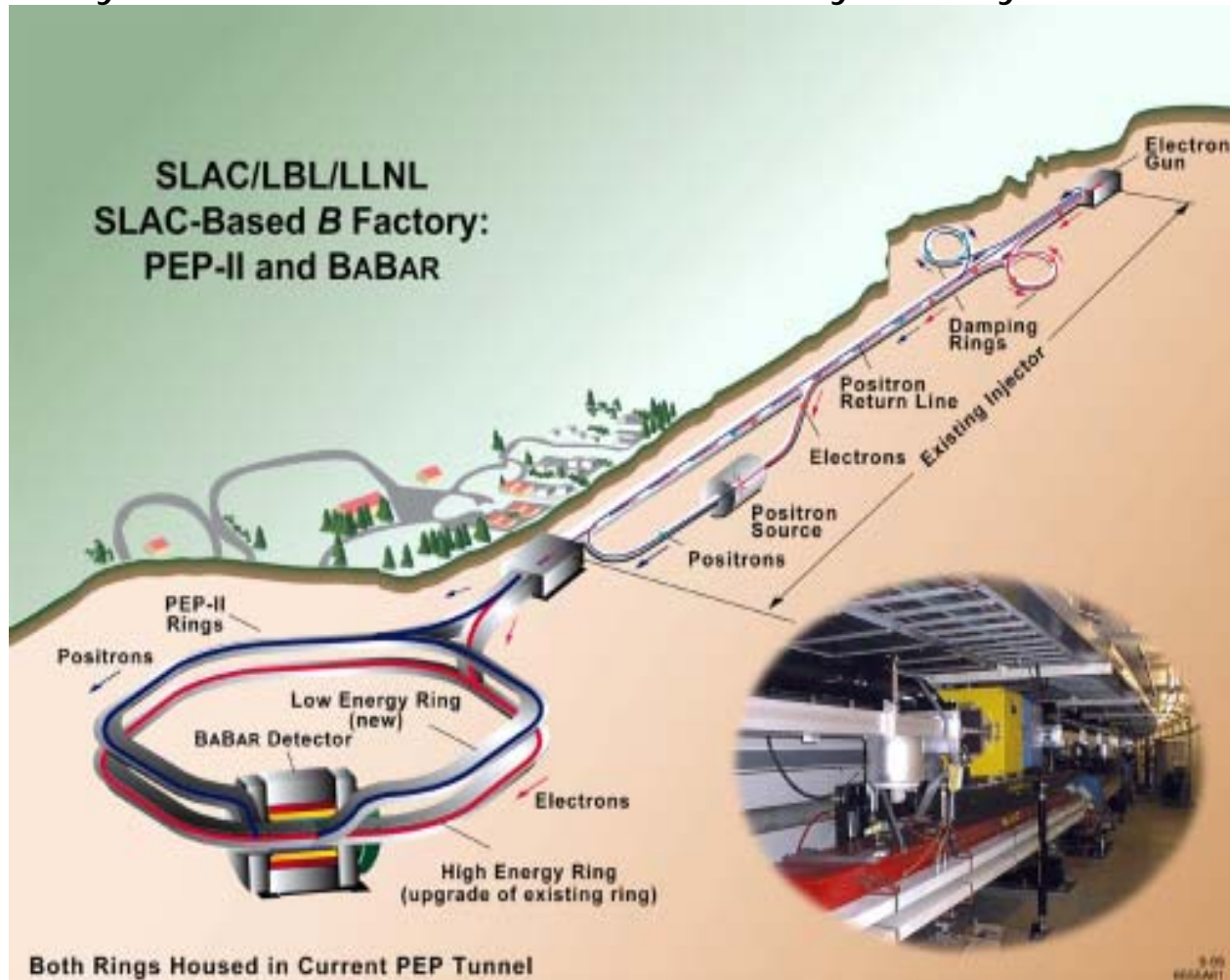

# Matter-Antimatter Collisions

It is possible to accelerate protons and antiprotons to much greater energies than electrons and positrons. This effectively makes a quark-antiquark collider

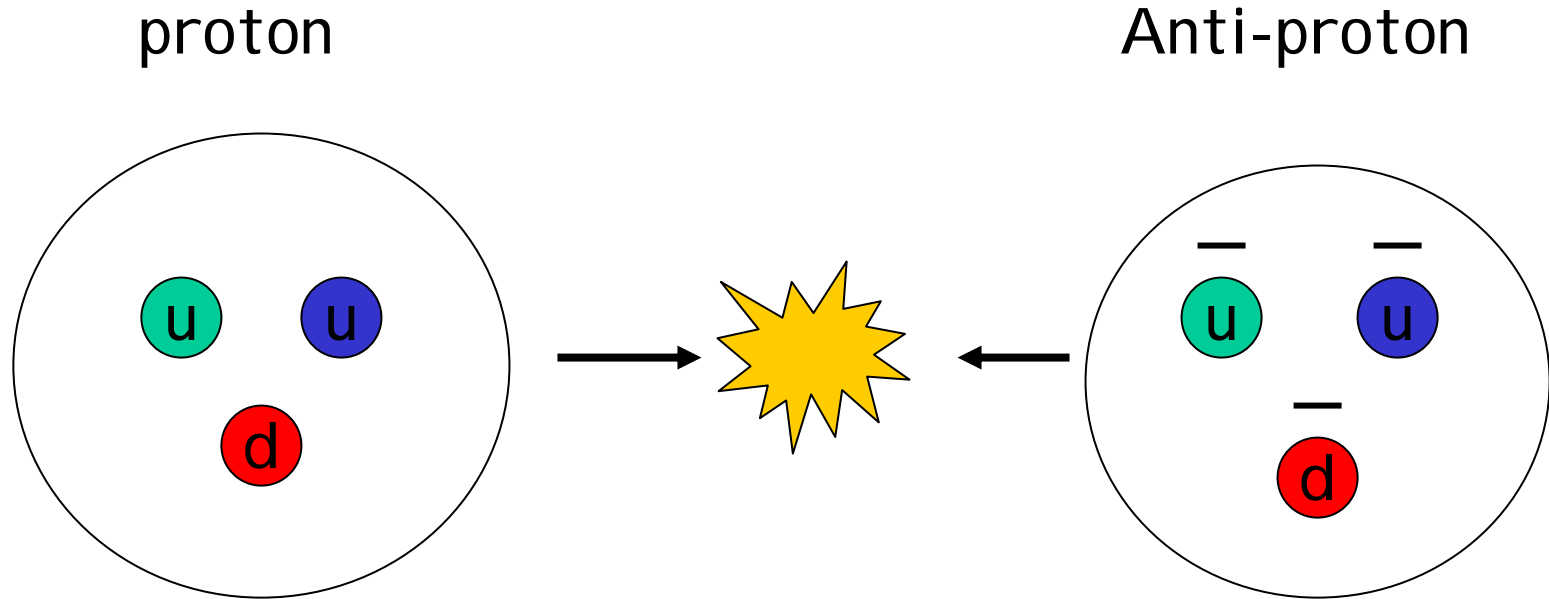

# Proton - Antiproton Collisions

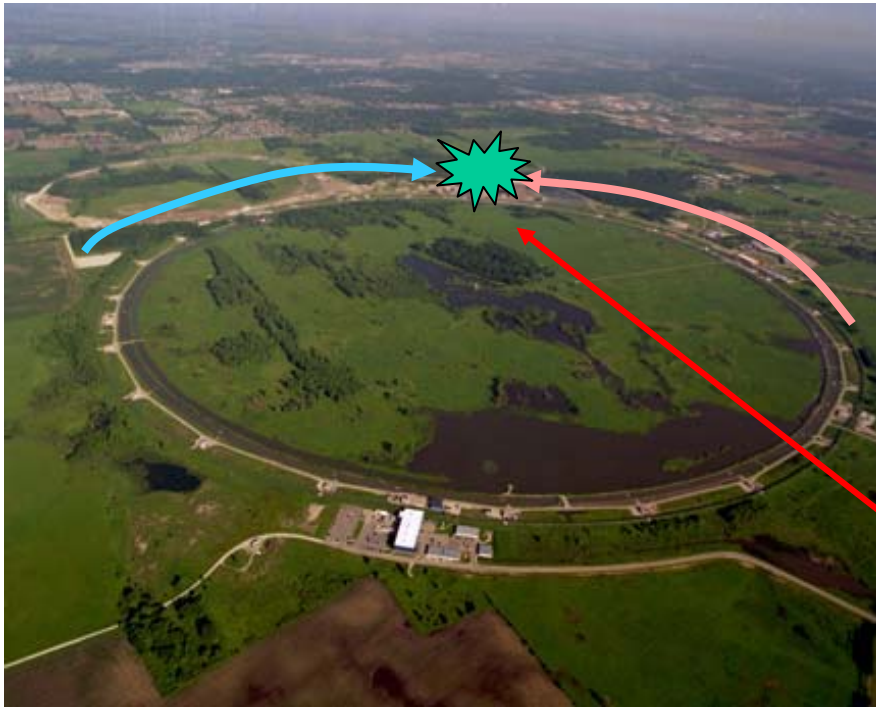

4 miles circumference

Fermilab (Chicago)

The worlds highest energy collider (until 2007)

980 GeV protons +  
980 GeV antiprotons



The CDF detector

# Discovery of the Top Quark

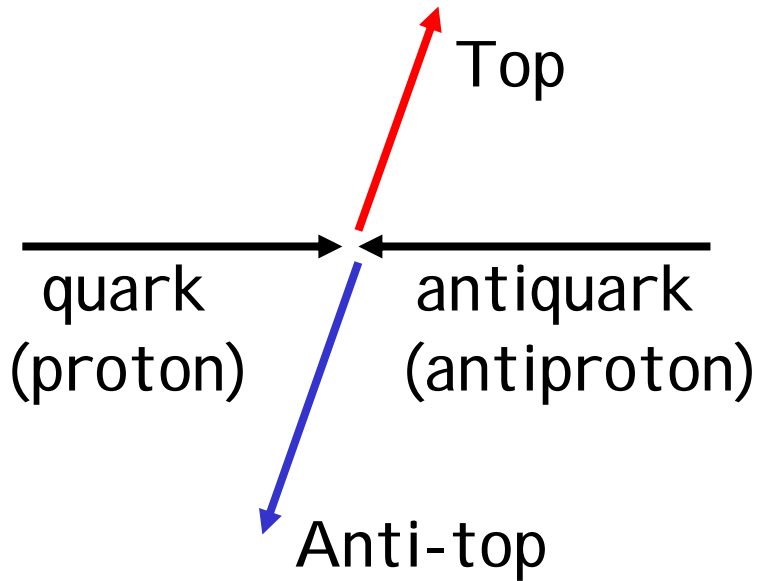

Top Quark Event

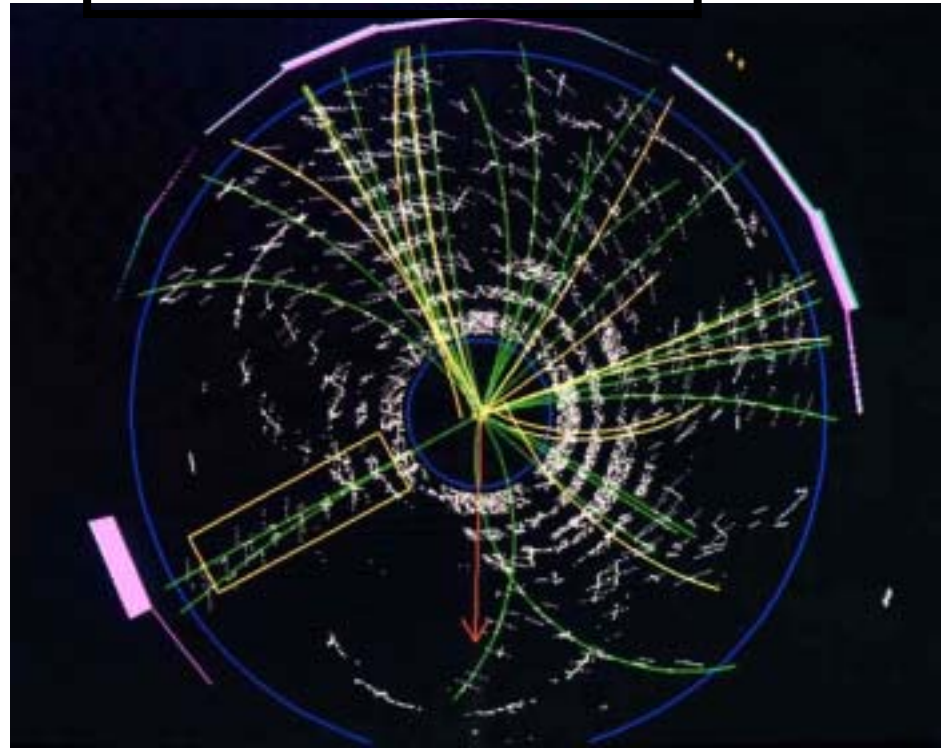

# The Next Big Thing - 2007

The LHC at CERN, Geneva. 16 Miles circumference, extends across France-Switzerland border. 14000 GeV



# The Higgs Boson

Missing piece to the puzzle: how do the  $W$ ,  $Z$ , quarks and leptons get their **mass**?

The Standard Model includes an explanation, the **Higgs mechanism**, but it is not well tested at all. It predicts a **spin 0** particle, the **Higgs boson**. We have never seen a spin 0 particle before, except for bound states.

Every high-energy collider has searched for it since ~ 1975. The Tevatron is looking for it now, though the LHC has the best chance once it turns on.

# Summary - The Standard Model

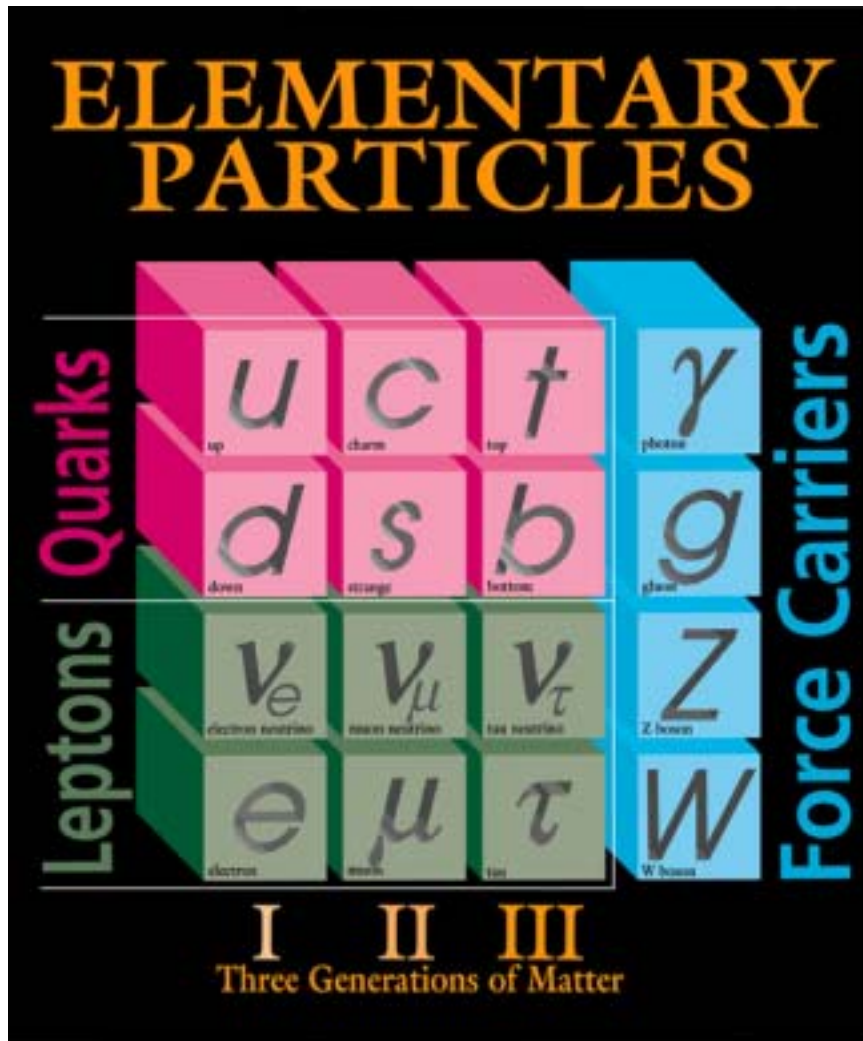

+ anti quarks  
anti leptons

missing in action:  
the Higgs boson

# Homework for (last +) next time

Order Griffiths, "Introduction to Elementary Particles"

Read Chapter 1 (history)

Skim Chapter 2 (intro. Feynman diagrams)

Read Chapter 3 (relativistic kinematics)

Problem set due April 14.