

GLAST Large Area Telescope

**Instrument Flight Software
Flight Unit Design Review
16 September 2004**

LAT Housekeeping

**Sergio Maldonado
Stanford Linear Accelerator Center**

smaldona@slac.stanford.edu

650-926-4355

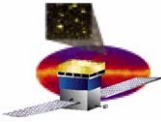

Housekeeping Requirements

- **Flight Software General Requirements:**
 - **LAT Housekeeping Data to SC (5.3.5.1.1)**
 - The SIU FSW shall provide housekeeping data to the SC, via the CTDB, on a schedule defined in the GLAST 1553 Bus Protocol ICD.
 - **LAT Housekeeping Data Set (5.3.5.1.2)**
 - The contents of this data set shall be as defined in the LAT Flight Software Telecommand and Telemetry Formats document.
 - **Housekeeping (5.3.5.1.3)**
 - The SIU FSW shall acquire and monitor health and environmental data, as defined in the LAT Flight Software Telecommand and Telemetry Formats document and the LAT Housekeeping design document, from the LAT power distribution subsystem and the CAL, TKR, ACD and T&DF subsystems.
 - **Low Rate Science (5.3.5.1.3)**
 - The SIU FSW shall acquire low-rate science data (rate counters) from the CAL, TKR, ACD, and T&DF subsystems for transmission to the ground via telemetry.



FSW Layer Architecture

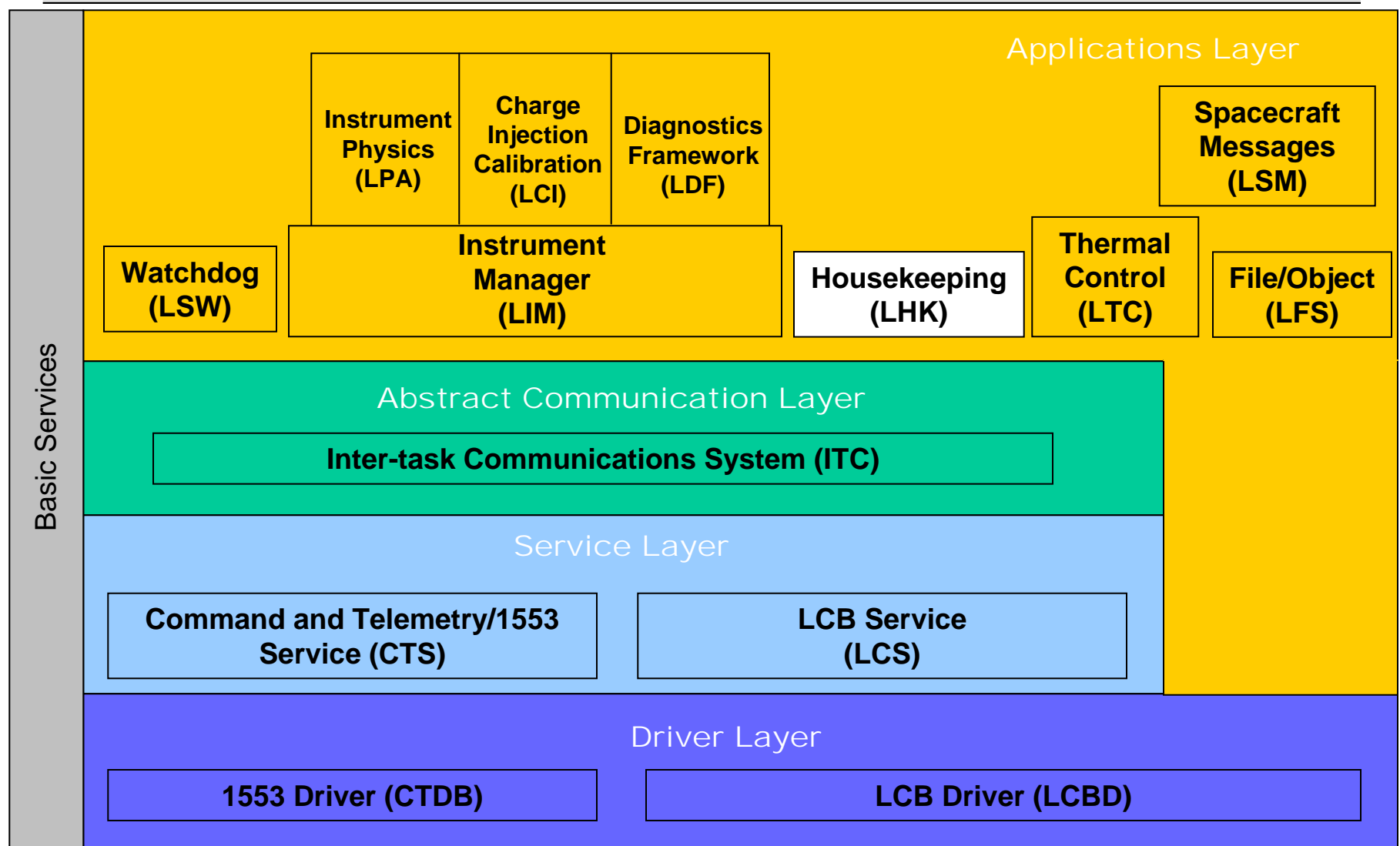

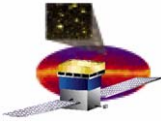

Functional Components

- **Functional Inputs**
 - From the ground, the Housekeeping function receives telecommands in 1553 CCSDS format.
 - From the 1553 controller, the Housekeeping function receives telemetry requests.
 - From the LAT file system, the Housekeeping function uses housekeeping specific configuration files.
- **Functional Processing**
 - From the LAT, the Housekeeping function accumulates:
 - Voltages, currents, and temperatures from hardware
 - Low rate science counters, processor metrics, and communications statistics from software counters
 - The Housekeeping function checks limits on appropriate health and environmental data against thresholds defined in the housekeeping configuration files.
- **Functional Outputs**
 - The Housekeeping function sends housekeeping data as 1553 CCSDS telemetry packets on the 1553 data bus.

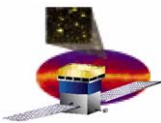

LAT FSW Architecture (Housekeeping Specific)

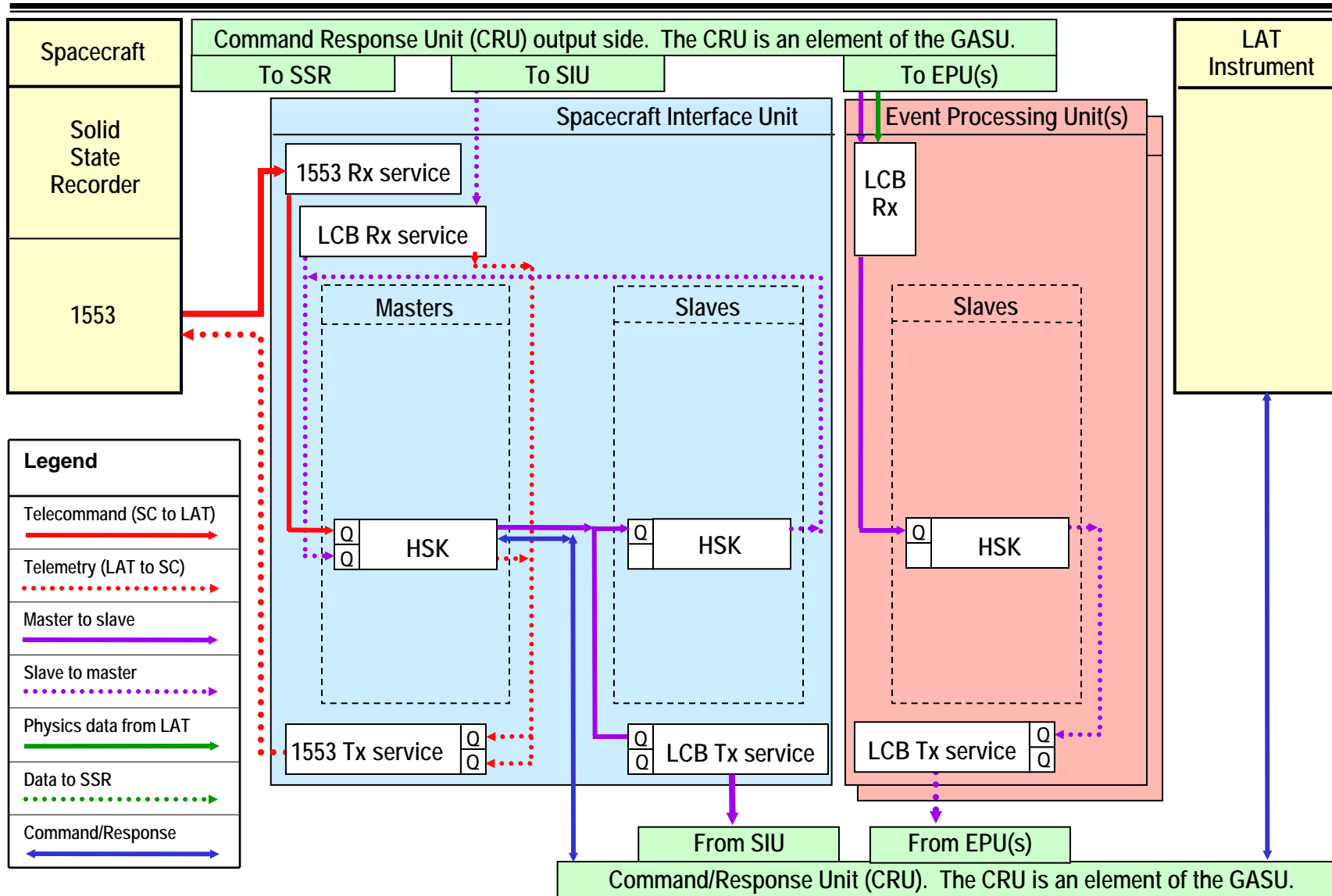



Housekeeping Architecture (cont'd)

- Housekeeping operation is maintained by separate tasks executing on multiple CPUs. A master task running on the SIU performs critical actions like managing collection, packetization, and limit validations. Slave tasks operating on the EPU collect autonomous and demand data and forward it to the master task.
- The housekeeping master task performs the following duties:
 - reads housekeeping specific configuration files from the LAT file base
 - schedules and performs reading of hardware monitors and software counters
 - requests/collects data from slave tasks operating on EPUs
 - performs limit checks on data and raises appropriate alarms
 - services asynchronous/synchronous requests for data sets
 - formats data to CCSDS telemetry packets
 - outputs packets to 1553 data bus
- The housekeeping slave tasks perform the following duties:
 - services requests from the housekeeping master task
 - schedules and performs reading of software counters

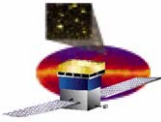

Housekeeping Data Categories and Schedules

- **FSW reports two categories of housekeeping data:**
 - **Critical data**
 - Reported in a single dedicated packet starting each telemetry transfer that is sent by the LAT to the Spacecraft
 - Environmental data from sensors around the instrument; CPU performance metrics
 - **Commanded and non-critical data**
 - Low-rate science data
 - Transferred via normal priority queues to the 1553 data bus.
- **The Housekeeping system operates on two schedules:**
 - **Acquisition schedule**
 - The schedule on which sensors are read
 - Order in which to read sensors
 - Frequency at which sensors are read
 - **Reporting/delivery schedule**
 - The schedule on which housekeeping data items are reported in telemetry

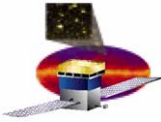

Collecting Data from the Hardware

- **Most housekeeping data is acquired by writing a value to one register, waiting a predetermined amount of time, and then reading another.**
 - **The time at which the register is written to, plus a predetermined or negligible wait period, is the time at which the actual measurement occurred.**
- **The LAT internal broadcast facility will be used throughout the housekeeping processes to:**
 - **Simultaneously write to registers across multiple towers**
- **Environmental Data:**
 - **Analog and digital environmental quantities for voltages, currents, and temperatures are provided by each TEM, each PDU (primary/redundant), and each AEM (primary/redundant).**
 - **Most of the values are read from hardware registers fronting for 12 bit ADCs.**
 - **All environmental housekeeping is considered critical telemetry.**
- **Low Rate Science:**
 - **The AEM, GEM, and each TEM provide low rate science counters.**
- **CPU Metrics (SIU and EPU) :**
 - **Housekeeping collects CPU idle time, CPU junction temperature, memory usage, cache misses, and task statistics**



Housekeeping Configuration

- After boot, the Housekeeping system initializes with a default configuration stored as part of the LHK image, but loadable configurations can override the defaults
 - The files can be interchanged via 1553 ground commands
- 4 types of files are used to define configuration:
 - Reporting/delivery configuration file: contains packet addressing data and the reporting/packet delivery schedule
 - Acquisition configuration file: contains mask values used to select which housekeeping data values to collect
 - Limit table values file: contains threshold values for limit checking
 - Limit table enabling file: contains mask values describing which value to limit check
- Loadable configuration files are read directly from the file system
 - Config file headers are validated and file contents are checksummed
- The LHK package provides utilities to produce the default configuration binary and modify the default to create loadable binaries

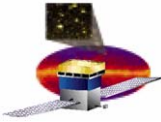

Housekeeping Telecommands

- **Telecommands**
 - The ground can send a telecommand to modify the behavior of the housekeeping system:
 - For instance, collection, schedule, and limit tables can be updated via configuration file reads.
 - Threshold checking, alarming, and alarm response actions can be enabled or disabled.
 - The ground can upload a telecommand to request on-demand telemetry
- **Telemetry**
 - Critical housekeeping occupies the first 116 bytes of every LAT telemetry frame
 - Non-critical housekeeping packets

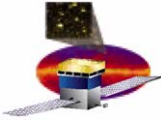

Forward Work

- **Coding is 85% complete**
- **The ability of Housekeeping system to collect a subset of housekeeping data, packetize the data, and send the packets over the 1553 interface was performed in June**
 - **A second demo of the Housekeeping system, in which a full range of housekeeping data will be collected from a fuller set of hardware, is scheduled for January 2005**
- **Coding and unit testing complete 10/15/04**

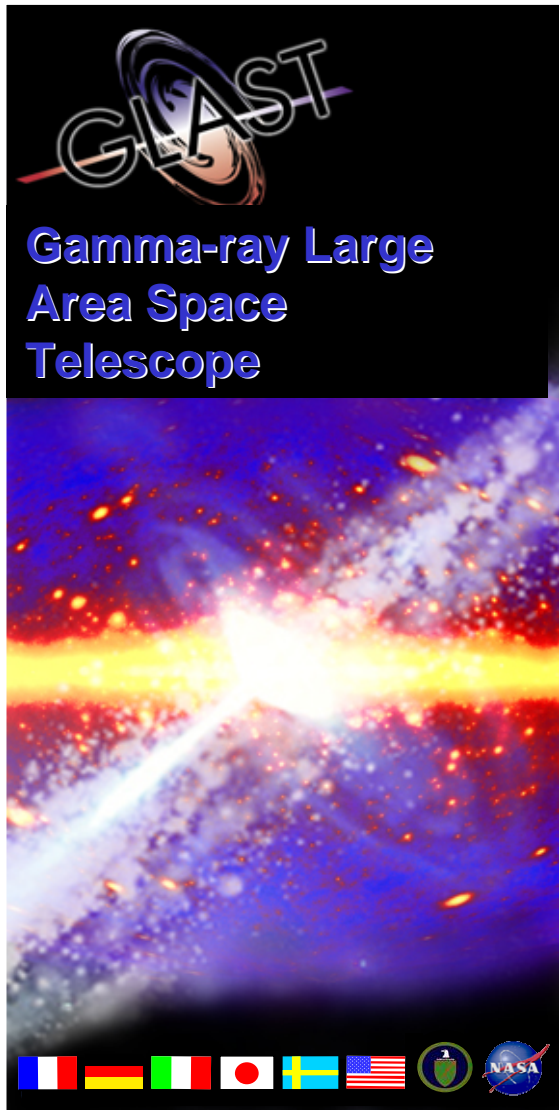
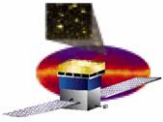

GLAST Large Area Telescope

Backup

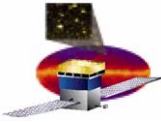

LHK Software Package Organization

- **Flight Components**
 - **Shareables**
 - **liblhk** - The housekeeping master
- **Ground Support and Testing Components**
 - **Shareables**
 - **liblhk_cfg** – Default Housekeeping configuration, provided as a shareable library
 - **liblhk_sim** - The housekeeping master using simulated data (no LCB)
 - **liblhk_scp** - SCP (Spacecraft control program) telecommand routines
 - **libLAT_enet** - Application driver 1553 ethernet simulation of LAT initialization and control
 - **libLAT_sumt** - Application driver 1553 summit dependent LAT initialization and control
 - **libSC_enet** - Application driver 1553 ethernet simulation of SC control
 - **libSC_sumt** - Application driver 1553 summit dependent SC control
 - **Executables**
 - **LAT_enet** - host platform only test application driver program (LAT side)
 - **SC_enet** - host platform only test application driver program (Spacecraft side)
 - **Utilities**
 - **lhk_gen_cfg.py** - python script that generates and builds default configuration files
 - **lhk_build_cfg** - shell script to compile configuration file to binary format

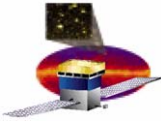

LHK Configuration Management

- LHK directly uses the following packages/constituents:
 - [CCSDS](#)
 - [CLI](#)
 - [CTDB](#)
 - [CTS](#)
 - [LEM](#)
 - [FILE](#)
 - [ITC](#)
 - [LCB](#)
 - [MSG](#)
 - [PBS](#)
 - [VXW](#)
 - [ZLIB](#)
- The dependency tree, constituent list, command and telemetry list, and other configuration management information related to LHK are published dynamically on the FSW Web site at http://www.slac.stanford.edu/exp/glast/flight/web/a_pnp/Pack_LHK.shtml