

**Gamma-ray Large
Area Space
Telescope**



GLAST Large Area Telescope

**Instrument Flight Software
EM2 Review
26 February 2004**

LAT Housekeeping

**Sergio Maldonado
Stanford Linear Accelerator Center**

smaldona@slac.stanford.edu

650-926-4355

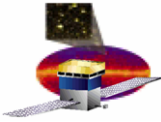

LAT Housekeeping: Requirements

- **Flight Software General Requirements:**
 - **Req. [5.3.4.8.1](#): FSW shall acquire and monitor health and environmental data from the CAL, TKR, ACD, T&DF, and LAT power-supply subsystems. The FSW shall be capable of responding to out-of-limits data by performing instrument shutdown or safing procedures.**
 - **Req. [5.3.4.4.1](#): The SIU FSW shall provide housekeeping data to the SC via the CTDB, on a schedule defined in [7]. The contents of this data set shall be as defined in the LAT Command and Telemetry List (TBS).**
 - **Req. [5.3.1.5](#): FSW shall export all science and housekeeping data via the science data and CTDB interfaces, respectively, for external storage.**

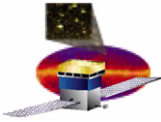

LAT Housekeeping: Functional Components

- **Functional Inputs**
 - From the ground, the Housekeeping function receives telecommands in 1553 CCSDS format.
 - From the 1553 controller, the Housekeeping function receives telemetry requests.
 - From the LAT file system, the Housekeeping function uses housekeeping specific configuration files.
- **Functional Processing**
 - From the LAT, the Housekeeping function accumulates:
 - Voltages, currents, and temperatures from hardware
 - Low rate science counters, processor metrics, and communications statistics from software counters
 - The Housekeeping function checks limits on appropriate health and environmental data against thresholds defined in the housekeeping configuration files.
- **Functional Outputs**
 - The Housekeeping function sends housekeeping data as 1553 CCSDS telemetry packets.

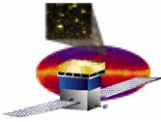

LAT FSW Architecture (Housekeeping Specific)

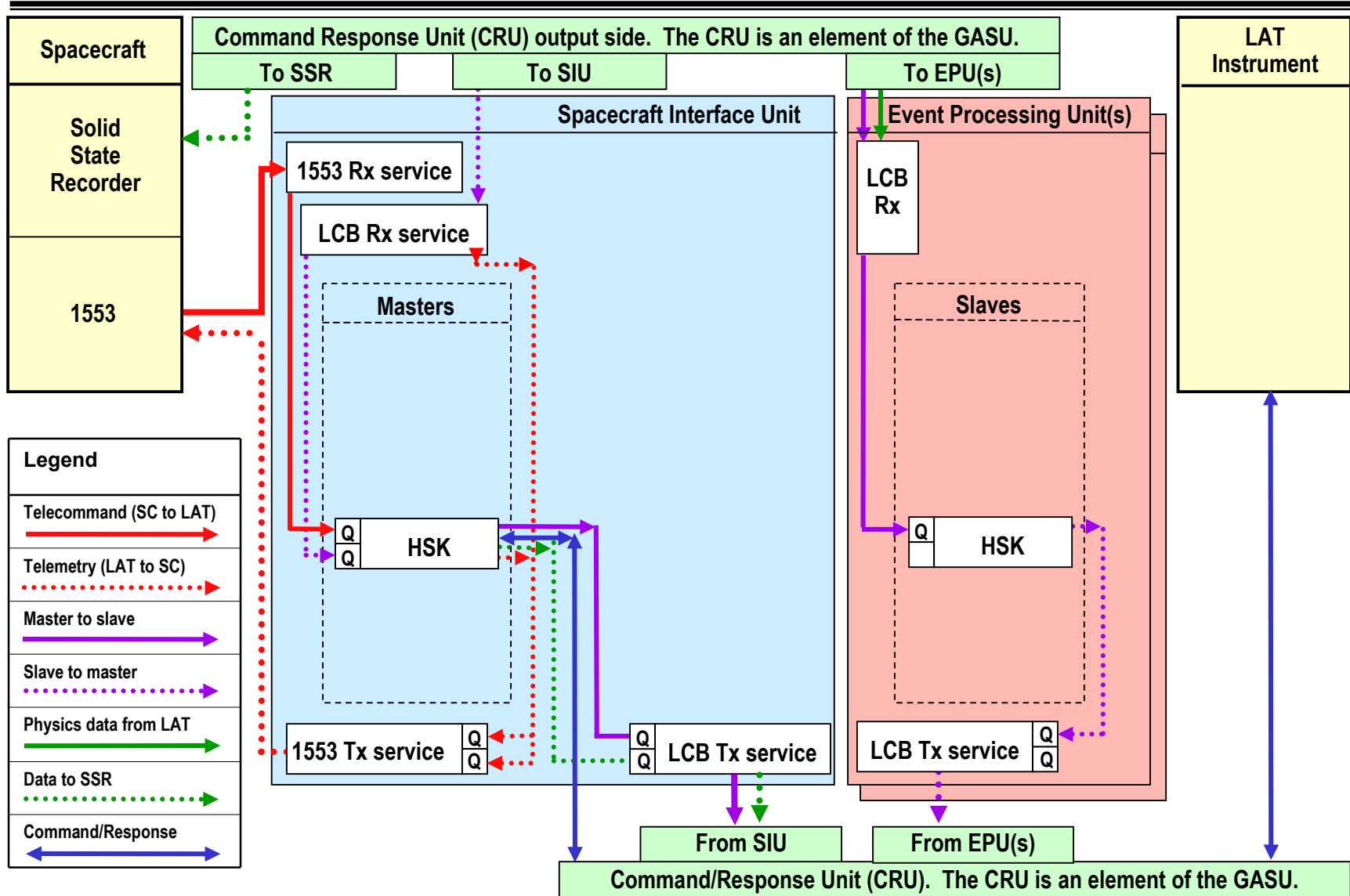

26 February 2004

EM2 Review - LAT Housekeeping

4

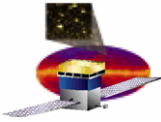

Housekeeping FSW: Architecture (cont'd)

- Housekeeping operation is maintained by separate tasks executing on multiple CPUs. A master task running on the SIU performs critical actions like managing collection and packetization. Slave tasks operating on the EPU collect autonomous and demand data and forward it to the master task.
- The housekeeping master task performs the following duties:
 - reads housekeeping specific configuration files from the LAT file base
 - schedules and performs reading of hardware monitors and software counters
 - requests/collects data from slave tasks operating on EPUs
 - performs limit checks on data and raises appropriate alarms
 - services asynchronous/synchronous requests for data sets
 - formats data to CCSDS telemetry packets
 - outputs packets to 1553 data bus
- The housekeeping slave tasks perform the following duties:
 - services requests from the housekeeping master task
 - schedules and performs reading of software counters

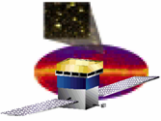

Housekeeping FSW: Scheduler

- There are both autonomous and commanded collection schedules for housekeeping data.
 - Instrument mode and/or state combined with housekeeping specific configuration files determine how and when the data is collected.
- Data sets are requested asynchronously via telecommands to the LAT, and synchronously by the 1553 service. The housekeeping master must be able to simultaneously service both types of requests.

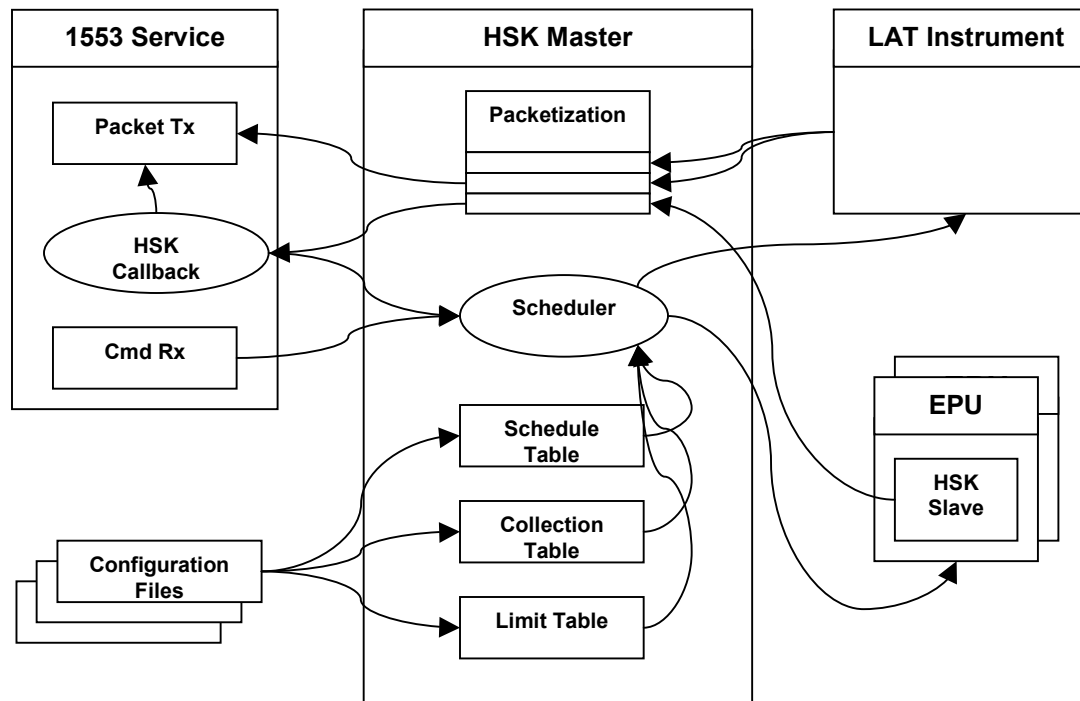

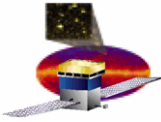

LAT Housekeeping: Telecommands and Telemetry

- **Telecommands**
 - The ground can upload a telecommand to modify the behavior of the housekeeping system:
 - For instance, collection, schedule, and limit tables can be updated via configuration file reads.
 - Threshold checking, alarming, and alarm response actions can be enabled or disabled.
 - The ground can upload a telecommand to request demand telemetry
- **Telemetry**
 - Once data has been collected, it must be formatted into CCSDS packets for 1553 transmission.
 - Priority housekeeping occupies the first 116 bytes of every LAT telemetry frame.
 - The remaining housekeeping data is transmitted to the 1553 service using the normal priority queues.

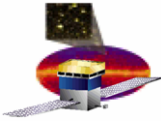

LAT Housekeeping: Testing

- **Test Setup**
 - **FSW Test Bed**
 - **1553 service provided by SIIS or emulation**
 - **LTX**
- **Telemetry Structure Tests**
 - **Verify that all housekeeping telemetry structures conform to the formats specified in the Telecommand and Telemetry dictionary.**
- **Telemetry Responses Tests**
 - **Verification of housekeeping telemetry CCSDS formatting and response delivery to the 1553 service.**
- **Configuration File Operations**
 - **Verify that housekeeping operation conforms to configurations set forth in associated schedule, collection, and limit configuration files.**
- **Limit Threshold Evaluation Tests**
 - **Verify that measurements are evaluated against proper threshold limits, and the appropriate action is taken in response to out of limit conditions.**
- **Performance Monitoring Tests**
 - **Verify that all housekeeping data is sampled, evaluated, and delivered at the required rates.**
 - **Verify that out of limit condition handling is executed within required time constraints**

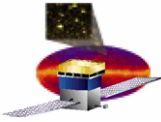

LAT Housekeeping: Consumers

	Test Stands		ISIS	I&T	FSW Test-bed	FSW Deliverable
	TKR,CAL	ACD				
Housekeeping data stream	Y	Y	Y	Y	Y	Y

- **Status:**
 - The design of the housekeeping function and a first pass implementation of the LHK package are complete.
- **Test Stands and Test-bed:**
 - As hardware is added to test stands, engineers will wish to gather housekeeping data from new components and subsystems.
- **ISIS:**
 - Spectrum Astro needs a working housekeeping function for GSE testing.
- **I&T:**
 - Integration and Test must have housekeeping data when they test the integrated instrument.