

Peer Design Review of Mechanical, Thermal, and Electrical

16 August 2001

**Stanford Linear Accelerator Center
Stanford CA**

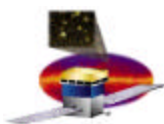

Introduction

- LAT viewed from the bottom

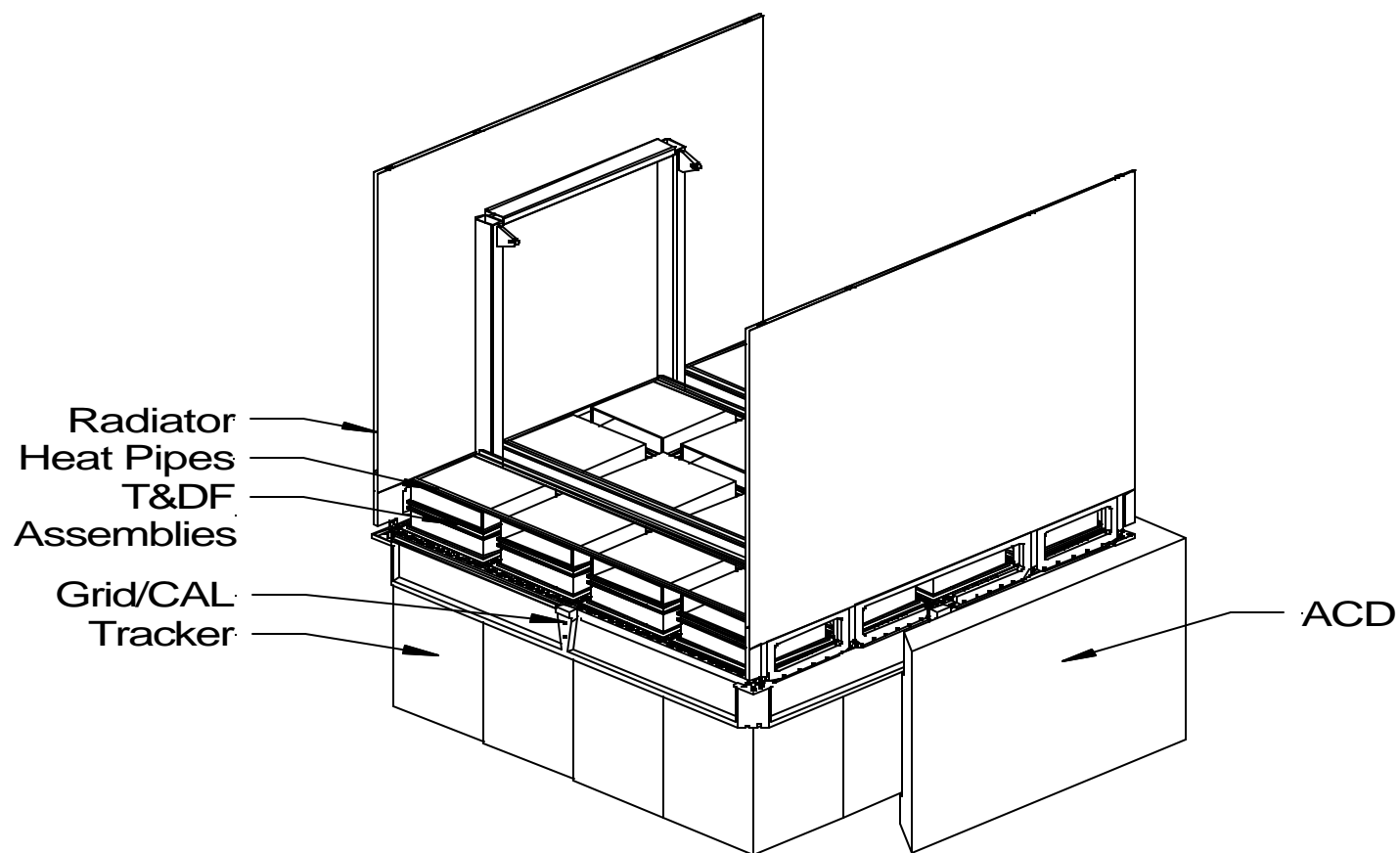

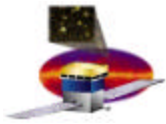

Mechanical layout(1)

- **16 T&DF assemblies**
 - Each assembly is ~ 316 mm X 316 mm X 230 mm
 - Has separate cooling system from the Grid
 - Thermally Isolated from Grid
 - Heat pipes connect to both radiators and the T&DF assemblies for uniform cooling
 - Material
 - Sides are 4 mm thick, bottom and top are 6 mm thick Al
 - Provides good thermal impedance
 - Provides excellent shielding

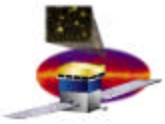

Mechanical layout(2)

Close up of one T&DF Assembly

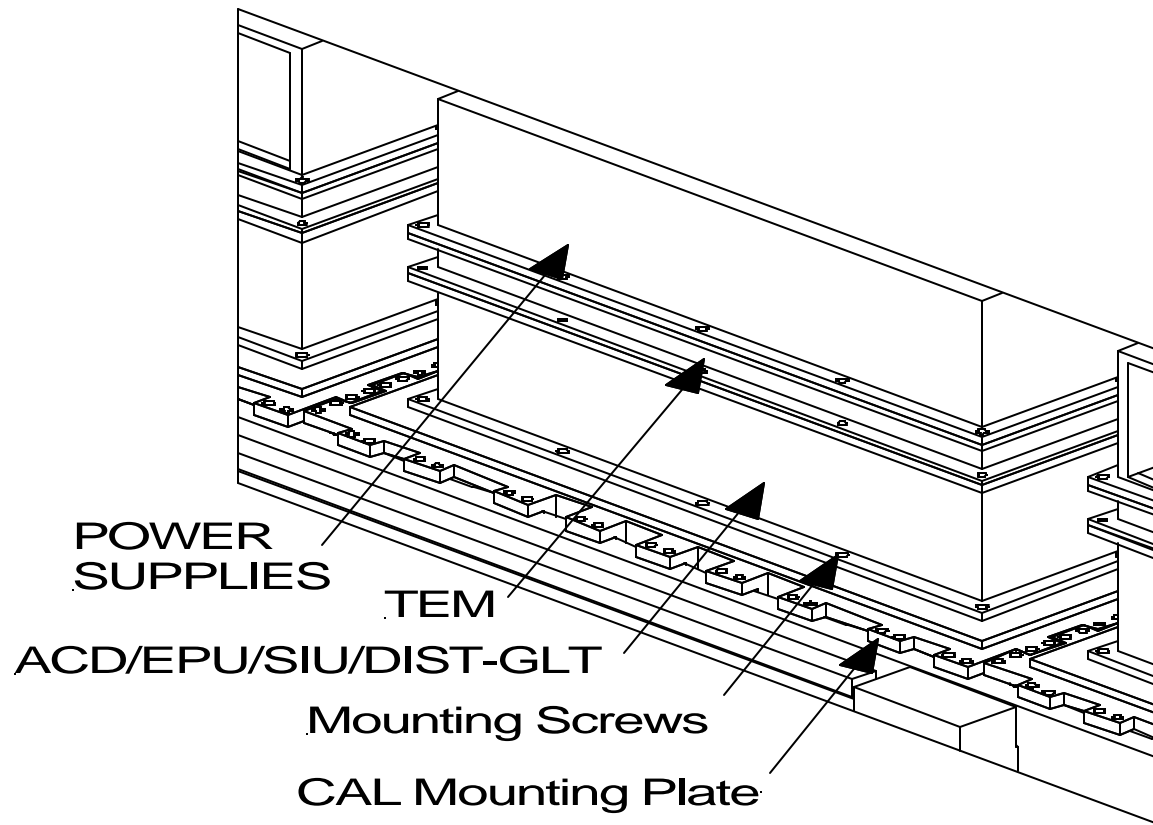

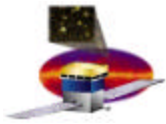

T&DF Assembly Design

- Each assembly consists of three subassemblies
 - The order of the assemblies may change
 - Probably want the TEM closest to CAL base plate
 - Power supply unit – 100 mm deep
 - Tower Electronics Module (TEM) – 30 mm deep
 - Other subsystems – 100 mm deep
 - Contains - SIU, EPU, Dist-GLT, ACD Assembly
 - Dist-GLT Assemblies cover four inner towers that contain
 - » Global Trigger, (GLT)
 - » Power distribution
 - » T&DF Patch panel

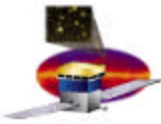

Cable Interconnections (1)

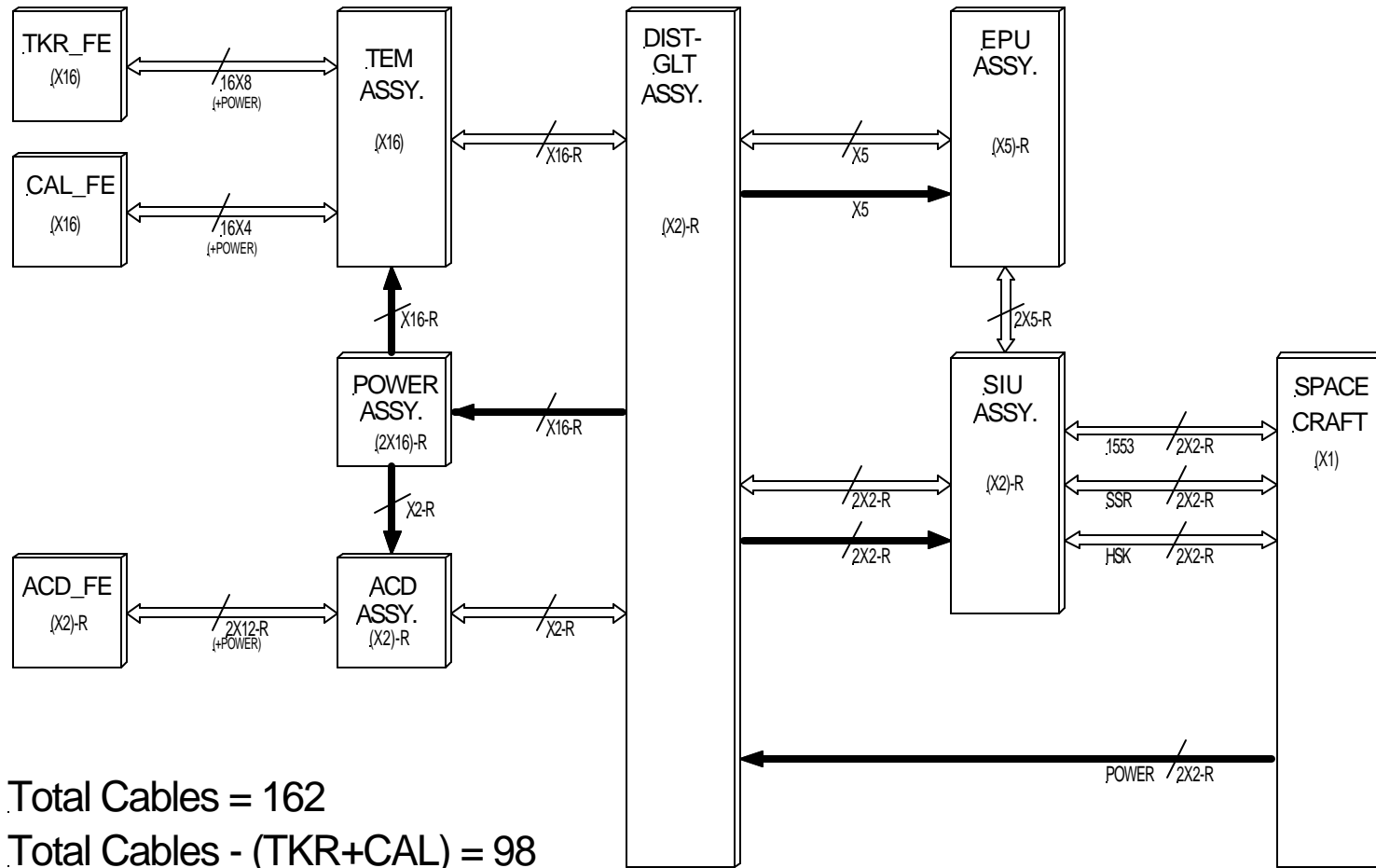

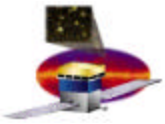

Cable Interconnections (2)

- **Cables/Connectors**
 - **Applicable documents**
 - **LAT-SS-00293 - T&DF Electrical Interface Specification**
 - **LAT-SS-00294 - T&DF Interface Control Specification**
 - **Total T&DF cables**
 - **98 cables (tbr)**
 - All very short except ACD front end and Spacecraft
 - Open issue is that the CAL prefers separate power cables because of possible digital noise pickup and ease of testing CAL front ends. Cost is 64 additional cables, complexity, weight
 - **192 cable connectors from TKR+CAL front ends**
 - Not reducible.
 - **Power Connectors from Spacecraft (tbd)**
 - **All other Connectors are Micro-D (tbr)**
 - **All T&DF cables are shielded**

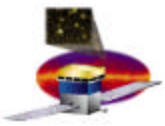

Grounding & Shielding (1)

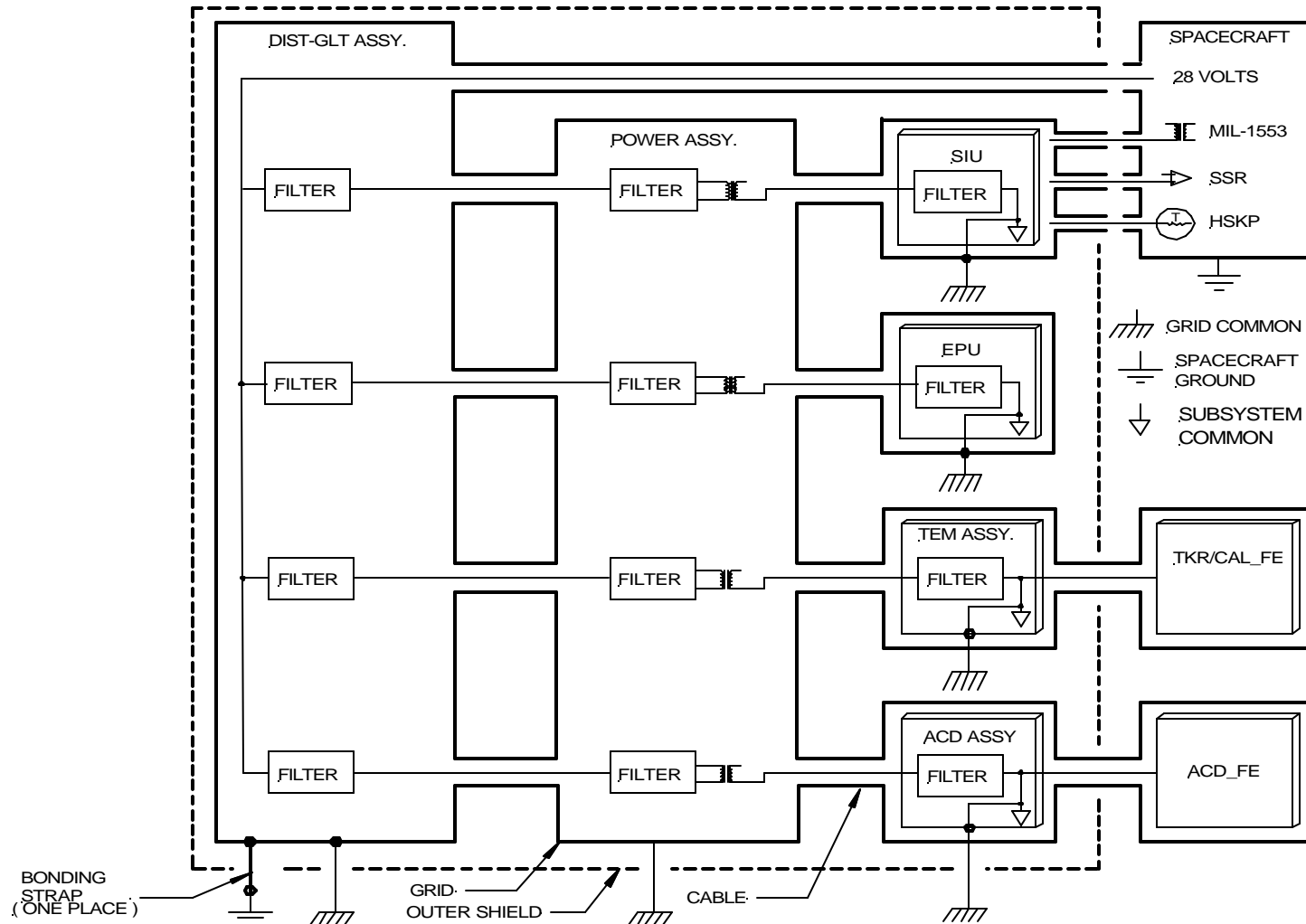

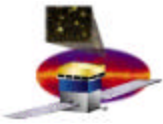

Grounding & Shielding (2)

- **Documents**
 - **NASA-HDBK- 4001 Electrical Grounding Architecture for Unmanned Spacecraft**
 - **GSFC 433-RQMT-0005 EMI Requirements document**
 - **LAT-SS-00291 LAT Grounding & Shielding**
- **Conceptual design**
 - **The Grid and the T&DF assemblies are grounding point for all assemblies**
 - **The Grid is thick, 8 mm, Al.**
 - **T&DF assemblies are electrically connected to the Grid**
 - **Overall shield covering the entire T&DF assemblies**
 - **Spacecraft is isolated with filters**
 - **Spacecraft communications are isolated with LVDS, transformers, relays, and isolation resistors**

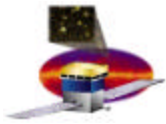

Power & Mass

- **Power**
 - **150 Watt**
- **Mass**
- **Allocation – 154 kg**
 - **Mechanical enclosures 139 kg**
 - **Cables 20 kg**
 - **Printed Wire Boards 80 kg**
 - **Total 239 kg**