



DCN No.  
LAT-XR-07131-01

## LAT PROJECT DOCUMENT CHANGE NOTICE (DCN)

SHEET 1 OF 2

**ORIGINATOR:** Mike DeKlotz      **PHONE:** 650-926-4752      **DATE:** 8/16/05

**CHANGE TITLE:** DCN for LAT Flight Software Test Procedures      **ORG.:**

DOCUMENT NUMBER	TITLE	NEW REV.
LAT-TD-07126	LAT FSW Qualification Test Procedure: DCMODE_001: ACD Diagnostics & Calibration	01
LAT-TD-07127	LAT FSW Qualification Test Procedure: DCMODE_002: ACD Diagnostics & Calibration	01
LAT-TD-07128	LAT FSW Qualification Test Procedure: DCMODE_003: TKR Diagnostics & Calibration	01
LAT-TD-07129	LAT FSW Qualification Test Procedure: NBTLMV_001: Narrowband Telemetry Housekeeping & Low-rate Science Data Verificaiton	01
LAT-TD-07130	LAT FSW Qualification Test Procedure: NBTLMV_002: Diagnostic Telemetry Verification	01

**CHANGE DESCRIPTION (FROM/TO):**

LAT-TD-07132-01- LAT FSW Qualification Test Procedure: FSWINI\_001: FSW Initialization-SIU Primary Boot  
 LAT-TD-07133-01- LAT FSW Qualification Test Procedure: FSWINI\_002: FSW & LAT Initialization- Boot Self-Test & Boot Housekeeping Telemetry  
 LAT-TD-07134-01- LAT FSW Qualification Test Procedure: FSWINI\_003: FSW & LAT Initialization- Multiple Boot Images  
 LAT-TD-07135-01- LAT FSW Qualification Test Procedure: FSWINI\_004: FSW & LAT Initialization- SIU Hardware Reboot in response to the Signal on the Discrete Lines  
 LAT-TD-07136-01- LAT FSW Qualification Test Procedure: FSWINI\_005: FSW Initialization- EPU Primary Boot  
 LAT-TD-07137-01- LAT FSW Qualification Test Procedure: FSWINI\_006: FSW & LAT initialization- Reset Source  
 LAT-TD-07138-01- LAT FSW Qualification Test Procedure: FSWINI\_007: FSW & LAT Initialization- Storage & Retrieval of System Errors During SIU Primary Boot  
 LAT-TD-07139-01- LAT FSW Qualification Test Procedure: FSWINI\_008: FSW & LAT Initialization- Storage & Retrieval of System Errors During EPU Primary Boot  
 LAT-TD-07140-01- LAT FSW Qualification Test Procedure: FSWINI\_009: FSW & LAT Initialization- SIU Boot Status on Discrete Lines & SISU Boot Housekeeping Telemetry  
 LAT-TD-07141-01- LAT FSW Qualification Test Procedure: FSWINI\_010: FSW & LAT Initialization- SIU & EPU Secondary Boot  
 LAT-TD-07142-01- LAT FSW Qualification Test Procedure: FSWINI\_011: FSW & LAT Initialization- SIU & EPU Secondary Boot Error Mitigation  
 LAT-TD-07143-01- LAT FSW Qualification Test Procedure: FSWINI\_012: FSW & LAT Initialization- LAT SEU Protection  
 LAT-TD-07144-01- LAT FSW Qualification Test Procedure: FSWINI\_013: FSW & LAT Initialization- LAT Memory Scrubbing  
 LAT-TD-07145-01- LAT FSW Qualification Test Procedure: FSWINI\_014: FSW & LAT Initialization- Watchdog Management During Boot  
 LAT-TD-07146-01- LAT FSW Qualification Test Procedure: FSWINI\_015: FSW & LAT Initialization- Soft Reset  
 LAT-TD-07152-01 - LAT FSW Qualification Test Procedure:FECALB\_001: Charge Injection Calibration – TOT Measurements  
 LAT-TD-07153-01- LAT FSW Qualification Test Procedure:FECALB\_002: Charge Injection Calibration – TKR Threshold and Charge Scans  
 LAT-TD-07154-01- LAT FSW Qualification Test Procedure: FECALB\_003: Charge Injection Calibration – TKR Trigger Check  
 LAT-TD-07155-01- LAT FSW Qualification Test Procedure: FECALB\_004: Charge Injection Calibration – ACD Charge Injection  
 LAT-TD-07156-01- LAT FSW Qualification Test Procedure: FECALB\_005: Charge Injection Calibration – CAL Charge Injection  
 LAT-TD-07157-01- LAT FSW Qualification Test Procedure: WBTLMV\_001: Wideband Telemetry Verification – Science Data Format and Volume

**REASON FOR CHANGE:**

**ACTION TAKEN:**     Change(s) included in new release     DCN attached to document(s), changes to be included in next revision  
 Other (specify):

**DISPOSITION OF HARDWARE (IDENTIFY SERIAL NUMBERS):**

**DCN DISTRIBUTION:**

- No hardware affected (record change only)
- List S/Ns which comply already:
- List S/Ns to be reworked or scrapped:
- List S/Ns to be built with this change:
- List S/Ns to be retested per this change:
- 

**SAFETY, COST, SCHEDULE, REQUIREMENTS IMPACT?**     YES     NO

If yes, CCB approval is required. Enter change request number:

APPROVALS	DATE	OTHER APPROVALS (specify):	DATE
<b>ORIGINATOR:</b> M. DeKlotz (signature on file)	8/16/05		
<b>ORG. MANAGER:</b> D. Horn (signature on file)	8/16/05		
PSA- K. Burlingham (signature on file)	8/16/05		
<b>DCC RELEASE:</b> Natalie Cramar (signature on file)	8/16/05	Doc. Control Level: <input checked="" type="checkbox"/> Subsystem <input type="checkbox"/> LAT IPO <input type="checkbox"/> GLAST Project	

DCN No: LAT-XR-07131-01



DCN No.  
LAT-XR-07131-01

SHEET 2 OF 2

## LAT PROJECT DOCUMENT CHANGE NOTICE

### Continuation:

LAT-TD-07158-01- LAT FSW Qualification Test Procedure: FILMGT\_001: File Management Verification  
LAT-TD-07159-01- LAT FSW Qualification Test Procedure: MEMMGT\_002: Memory Load Data  
LAT-TD-07160-01- LAT FSW Qualification Test Procedure: NBTLMV\_003: ACD HSK Anomaly Response and Alert Telemetry Verification  
LAT-TD-07161-01- LAT FSW Qualification Test Procedure: OPMODE\_001: LAT Operational Mode Control  
LAT-TD-07162-01- LAT FSW Qualification Test Procedure: THRMCS\_001: LAT Thermal Control System  
LAT-TD-07163-01- LAT FSW Qualification Test Procedure: VSGIFV\_001: Discrete Signal Interfaces  
LAT-TD-07164-01- LAT FSW Qualification Test Procedure: CMDFNC\_003: 1553 Interface and Command Functional Verification  
LAT-TD-07054-01- LAT FSW Qualification Test Procedure: EVTPMO\_001: Event Performance Monitoring and Verification – Software-Related Deadtime  
LAT-TD-07055-01- LAT FSW Qualification Test Procedure: EVTPMO\_002: Event Performance Monitoring and Verification –Acquisition of VETO Rates from the GEM  
LAT-TD-07056-01- LAT FSW Qualification Test Procedure: EVTPMO\_003: Event Performance Monitoring and Verification – Level 1 Trigger Rates  
LAT-TD-07057-01- LAT FSW Qualification Test Procedure: EVTPMO\_004: Event Performance Monitoring and Verification – Monitor CNO Rates  
LAT-TD-07112-01- LAT FSW Qualification Test Procedure: EVTFIL\_001: Event Filtering – Interface from the Event Builder  
LAT-TD-07113-01- LAT FSW Qualification Test Procedure: EVTFIL\_002: Event Filtering – Event Filter Rates and Capacity  
LAT-TD-07114-01- LAT FSW Qualification Test Procedure: EVTFIL\_003: Event Filtering – Event Filter Reprogramming  
LAT-TD-07115-01- LAT FSW Qualification Test Procedure: EVTFIL\_004: Event Filtering – Event Filter Bypass

	Document # <b>LAT-TD-07136-01</b>	Date effective 8/16/05
	Author(s) Igor Kouzmenko	Supersedes
	Subsystem/Office Electronics & DAQ Subsystem	
Document Title <b>LAT FSW Qualification Test Procedure:</b>  <b>FSWINI_005: FSW Initialization -- EPU Primary Boot</b>		

---

**CHANGE HISTORY LOG**

Revision	Effective Date	Description of Changes
01	August 16, 2005	Original

**TABLE OF CONTENTS**

Table of Contents .....	3
1. Scope.....	5
1.1 Test Suite .....	5
1.2 Test ID .....	5
1.3 Requirement(s) Tested.....	6
2. DEFINITIONS AND ACRONYMS .....	7
2.1 Definitions.....	7
2.2 Acronyms .....	7
3. REFERENCES .....	8
3.1 Applicable Documents.....	8
4. REQUIREMENTS.....	9
4.1 Test Data, Equipment and Software .....	9
4.2 Quality Assurance.....	9
4.3 Safety .....	9
4.4 Warnings, Cautions, and Notes.....	10
4.5 General Instructions .....	10
5. SETUP .....	12
5.1 Hardware Setup.....	12
5.2 Software Setup .....	13
5.3 Setup Validation.....	15
6. TEST PROCEDURE FOR FSWINI_005.....	16
6.1 Test Objective .....	16
6.2 Test Input Files .....	17

---

6.3	Test Preparation .....	17
6.4	Test Procedure .....	18
7.	TEST POST-CONDITIONS AND OVERALL OUTCOME .....	23
7.1	Test Post-Conditions.....	23
7.2	Overall Outcome of FSWINI_005.....	23
8.	CERTIFICATION .....	24
	Appendix A: Deviations from THE Qualification Test Procedure.....	25

## 1. SCOPE

This document describes the procedure followed for qualification testing of the LAT FSW. This Qualification Test Procedure document describes one of the qualification tests executed to verify compliance with the requirements defined in the “Flight Software Specification – Level III” (LAT-SS-00399).

### 1.1 Test Suite

#### *FSWINI*

The Test Suite is a logical grouping of a set of tests based on common functionalities and can be executed as a suite of tests in some order when the pre-conditions and post-conditions for each test within the suite have been met successfully.

This test procedure *FSWINI\_005* belongs in the Test Suite *FSWINI* under the *FST* Project.

### 1.2 Test ID

#### *FSWINI\_005*

Note: Test *FSWINI\_005* contains one main script, *FSWINI\_005*, which can be run when the EPU is unpowered.

The following telecommands and telemetry are used in this test.

#### Telecommands

APID	FC	Cmd. Packet (L)	Description (L)
<u>0x644</u>	0	LMEMDUMPMEM	Memory Data Dump
0x662	1	<u>LIMLOADSHED</u>	Load Shed
0x663	4	<u>LIMMAINFEEDON</u>	Enable Main Power Feed
0x663	7	<u>LIMPOWEROFF</u>	Disable Instrument Power
0x663	6	<u>LIMPOWERON</u>	Enable Instrument Power
<u>0x644</u>	6	<u>LMEMLOADREG</u>	Processor Register Write
<u>0x640</u>	1	<u>LBTRESET</u>	Warm reboot

0x640 2 LPBCERRDUMP Error code pop

### **Telemetry**

APID	Tlm. Packet (L)	Description (L)
<u>0x261</u>	LBTEPU0HKP	EPU 0 Boot Housekeeping Telemetry
<u>0x262</u>	LBTEPU1HKP	EPU 1 Boot Housekeeping Telemetry

### **1.3 Requirement(s) Tested**

The Qualification Test Procedure described herein is performed to verify that the FSW satisfies the following requirement(s), quoted from the Flight Software Specification – Level III:

Requirement Number	Requirement Name	Requirement	Level of Requirements Verification in This Test
5.3.1.1	Power-up	FSW shall perform a primary boot in response to EPU0 or EPU1 power-up.	Partial  (FSWINI_001 verifies the power-up requirement on the SIU. FSWINI_005 verifies this requirement on the EPU(s))
5.3.1.2	Boot from SUROM	FSW shall perform a primary boot from RAD750 SUROM.	Partial  (FSWINI_001 verifies the power-up requirement on the SIU. FSWINI_005 verifies this requirement on the EPU(s))
5.3.1.2.3	RAM Initialization	Upon power-up or hardware reset, the primary boot software shall initialize the RAM required to execute the FSW.	Partial  (FSWINI_001 verifies the power-up requirement on the SIU. FSWINI_005 verifies this requirement on the EPU(s))
5.3.1.3	Boot with Watchdog Safeguard	FSW shall disable the watchdog for at least 5 minutes to ensure the hardware watchdog does not activate during the primary boot.	Partial  (FSWINI_001 verifies the power-up requirement on the SIU. FSWINI_005 verifies this requirement on the EPU(s))

If the requirement(s) quoted above cite external documents (e.g., “...Further details are provided in [11]”), consult LAT-SS-00399 for the list of citations.

## 2. DEFINITIONS AND ACRONYMS

The following terms, abbreviations, and acronyms are used in this document:

### 2.1 Definitions

Hz	Hertz, unit of frequency
V	Volt
W	Watt
s, sec	seconds

### 2.2 Acronyms

CAL	Calorimeter
EGSE	Electrical Ground Support Equipment
GASU	Global trigger Anti-collision Spacecraft Unit
PTR	Post Test Review
SIB	Storage and Interface Board
TEM	Tower Electronics Module
TKR	Tracker
TPS	Tower Power Supply
TRR	Test Readiness Review
QAE	Quality Assurance Engineer
TE	Test Engineer
VSC	Virtual Spacecraft

### 3. REFERENCES

The list below provides documents that are to be used as references for this procedure:

#### 3.1 Applicable Documents

<u>Document Number</u>	<u>Description</u>
<u>SPECIFICATIONS</u>	
LAT-SS-00399	LAT Flight Software Level III Specification
1196 EI-S46310-000	GLAST 1553 Bus Protocol Interface Control
LAT-TD-02659	LAT Flight Software Telecommand and Telemetry Formats
LAT-TD-0561	The Virtual Spacecraft (VSC)
<u>PROCEDURES</u>	
FSWINI_005_proc	
<u>PLANS</u>	
LAT-MD-00039	Performance Assurance Implementation Plan
LAT-MD-00078	GLAST LAT System Safety Program Plan
LAT-MD-00404	LAT Contamination Control Plan
LAT-MD-00408	LAT Program Instrument Performance Verification Plan
LAT-SS-00296	T & DF Test Plan
LAT-TD-00297	LAT Electronics Test Plan
LAT-TD-00786	LAT Flight Software Test Plan
<u>DRAWINGS</u>	
N/A	
<u>OTHER</u>	
LAT-MD-00091	GLAST Quality Manual
LAT-MD-00471	Control of Nonconforming Product
LAT-MD-00472	Corrective and Preventative Action
	BAE "RAD750 Board Appendix to the Hardware User's Manual"

## **4. REQUIREMENTS**

This section lists the requirements that shall be followed during the LAT FSW Qualification Testing process.

The Performance Assurance Implementation Plan, LAT-MD-00039, shall be utilized to ensure that the products produced by the GLAST LAT project intended for design qualification, flight and critical ground support equipment usage meet the required levels of quality and functionality for their intended purposes.

The LAT Program Instrument Performance Verification Plan, LAT-MD-00408, shall be utilized to address the testing to be performed at the unit/subsystem and instrument level for flight qualification, proto-flight and acceptance testing phases. Also included are the necessary processes/procedures and systems assurance activities.

### **4.1 Test Data, Equipment and Software**

This procedure shall follow the requirements found in the Control of Nonconforming Product, LAT-MD-00471. This document establishes the method to identify and control nonconforming product developed by the LAT project team.

### **4.2 Quality Assurance**

This procedure shall follow the requirements found in the Corrective and Preventative Action document, LAT-MD-00472 and the GLAST Quality Manual, LAT-MD-00091.

The Corrective and Preventative Action document establishes the method to be used to initiate, implement, evaluate and record corrective and preventive actions. The GLAST Quality Manual defines the methods implemented by the GLAST LAT project to ensure consistent quality of all processes for procurement, design, development and production of flight hardware, flight software and all associated ground support equipment interfacing with flight hardware and software.

### **4.3 Safety**

This procedure shall follow the requirements found in the GLAST LAT System Safety Program Plan, LAT-MD-00078. This document defines all phases of the LAT program including: design, development, fabrication, handling, transportation, storage, test, assembly and operation.

**WARNING: When high voltages are present extreme care should be exercised.**

#### **4.4 Warnings, Cautions, and Notes**

The following SAFETY ALERTS are intended to create awareness of the potential safety hazards and the steps that must be taken to avoid accidents. These same alerts are used throughout this document to identify specific hazards that may endanger personnel and/or equipment.

Identification of every conceivable hazardous situation is impossible. Therefore, all personnel have the responsibility to diligently exercise safe practices whenever exposed to this equipment.

**WARNING: Indicates a potential hazardous situation which, if not avoided, could result in death or injury.**

**CAUTION:** Indicates a potential hazardous situation which, if not avoided, could result in damage to equipment.

**Note:** Indicates a notification of information that is important, but not hazard related.

#### **4.5 General Instructions**

This qualification test procedure shall be conducted on a formal basis to its latest approved and released version. The designated Software QAE shall be notified 24 hours prior to the start of this procedure. Software QAE may monitor the execution of all or part of this procedure should they elect to do so.

The Test Engineer conducting this test shall read this document in its entirety and resolve any apparent ambiguities before beginning the procedures described herein.

Deviations from the procedures described in this document and breaks in hardware or software configuration can only be initiated by the Test Engineer, must be approved by QA, and must be documented in Appendix A.

Any nonconformance/defect/anomaly is to be reported in JIRA. Refer to the LAT Flight Software Test Plan LAT-TD-00786 for guidance. Do not alter or break configuration if a failure occurs. Notify Software Quality Assurance.

All success conditions for a test must be met for the test to pass.

## 5. SETUP

This section describes the hardware and software configuration used for the qualification test described later in this document. Any break from configuration or deviation from a particular procedure must be authorized by the Quality Assurance Engineer and documented in Appendix A.

### 5.1 Hardware Setup

The list below indicates the equipment that is used to execute the tests described in this document.

Hardware Unit	Manufacturer	GLAT Number (and Hardware Sub-Units by GLAT Number)	Firmware Version (where applicable)
Virtual Spacecraft (VSC)	SLAC		
Spacecraft Interface Unit (EPU0)	SLAC		
Event Processor Unit (EPU0)	SLAC		
Event Processor Unit (EPU1)	SLAC		
Global Trigger AEM Signal Distribution Unit (GASU)	SLAC		
1553 cables and couplers	SLAC		
Unix or Linux Host	SLAC		
Power supply for EPU	SLAC		

The Figure below depicts the Testbed on which this qualification test is performed. The particular hardware units utilized in this test are itemized by GLAT number and firmware version in the preceding table.

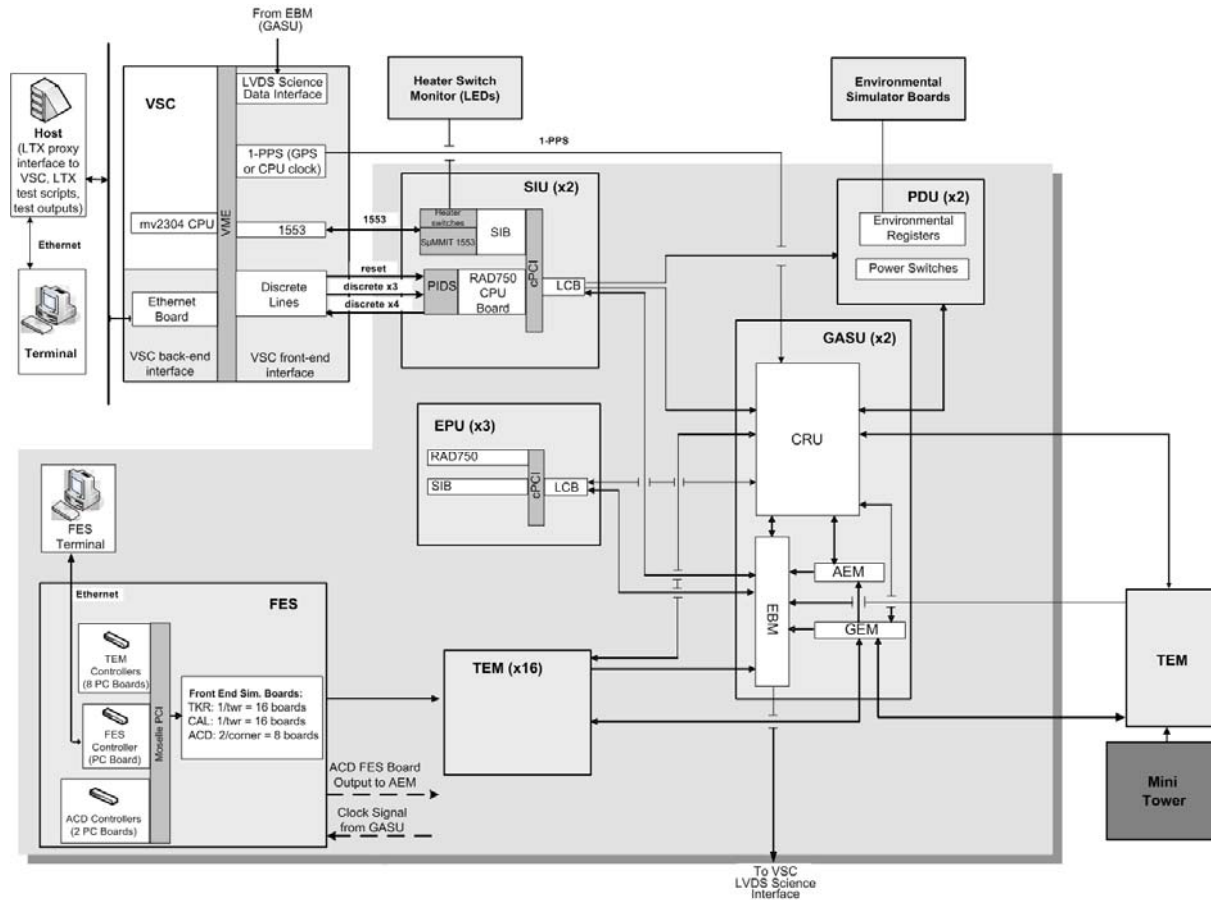

Figure 1. FSW Testbed

## 5.2 Software Setup

The software required to prepare for and execute the tests described in this Qualification Test Procedure document is itemized in this section.

### 5.2.1 Test Tools

The following table specifies the test executive used to run this qualification test, and identifies the other software tools used to support the execution of the test. The “Software Version Number” column identifies the version number of the test tool being used; alternatively, this column identifies the hardcopy attachment to this document that records the version of the tool being used (e.g., “Attachment 1”). The “Path to Attachment” column identifies the directory in which the electronic copy of any hardcopy attachment is saved (if applicable).

Software	Description of Software	Software Version Number (or Specify Attachment Number)	Path to Attachment (If Applicable)
LTX	LAT Test Executive		
FMX	File Management Extra		
VSC	Virtual Spacecraft system software		
VPI	VSC Python/Proxy Interface		

### 5.2.2 Test Scripts

The following table identifies the test scripts that are run to execute this qualification test. The “Script Version Number” column identifies which version of the script is being used; alternatively, this column identifies the hardcopy attachment to this document that records the version of the script being used (e.g., “Attachment 1”). The “Path to Attachment” column identifies the directory in which the electronic copy of any hardcopy attachment is saved (if applicable).

Test Script	Description of Test Script	Script Version Number (or Specify Attachment Number)	Path to Attachment (If Applicable)
FSWINI_005.py	The main LTX qualification test execution script for this test. This script must be run before the EPU RAD750 crate has powered up. The main part of this script may be useful to verify the pre-conditions for some tests that need to be conducted in the Boot Mode only.		
FSWINI_005.xml	LTX test description file for test FSWINI_005.		

### 5.2.3 Flight Software

This qualification test is performed on a complete, integrated Candidate Release of FSW. All FSW libraries under test are final Flight Unit Candidate versions. The test described in this document is designed to evaluate the particular FSW packages and constituents listed in the following table; for clarity, only those constituents that are the focus of the test are listed below.

FSW Package	Constituent(s)
PBC	

The Candidate Release into which these FSW constituents are integrated is identified in the following table. The “Candidate Release Build Number” column specifies the build number of the FSW Candidate Release under test (e.g., “B0-0-1”). The “Candidate Release Attachment Number” column identifies which hardcopy attachment to this document confirms the name and version number of the full set of FSW packages and constituents used in the test (e.g., “Attachment 2”). The “Path to Attachment” column specifies where in the test repository an electronic copy of the hardcopy attachment has been saved.

Candidate Release Build Number	Candidate Release Attachment Number	Path to Attachment

### 5.3 Setup Validation

#### 5.3.1 Hardware Validation

The following signatures confirm that the Test Engineer and Quality Assurance Engineer have verified the GLAT numbers, firmware version numbers, and the proper connection of all hardware listed in the table in Section 5.1.

\_\_\_\_\_

Date                      Time                      Test Engineer                      QAE

### 5.3.2 Software Validation

The Test Engineer performs the following procedure to validate the software setup for this qualification test and records completion of the setup validation steps in the space provided.

Step No.	Description of Step	Step Outcome
1	Obtain version numbers of the test tools used to perform this qualification test by running the <b>xxxx</b> script. Pick up and label the hardcopy report generated by the <b>xxxx</b> script and attach it to this test procedure document. Record (1) the label for the attachment in table and (2) the directory location to which an electronic copy of the report was saved in Section 5.2.1.	Complete/ Not Complete
2	Obtain version numbers of the tesc scripts used to perform this qualification test by running the <b>xxxx</b> script. Pick up and label the hardcopy report generated by the <b>xxxx</b> script and attach it to this test procedure document. Record (1) the label for the attachment and (2) the directory location to which an electronic copy of the report was saved in Section 5.2.2.	Complete/ Not Complete
3	Obtain the versions of the FSW packages loaded on the targets by running the <i>version_test</i> script <b>in the Boot mode</b> . Pick up and label the hardcopy report generated by the <i>version_test</i> script and attach it to this test procedure document. Record (1) the label for the attachment and (2) the directory location to which an electronic copy of the report was saved in Section 5.2.3.	Complete/ Not Complete

The following signatures confirm that, using the procedure described in the previous table, the Test Engineer and Quality Assurance Engineer have verified that all versions of test support software, test scripts, and FSW constituents match those identified in Section 5.2.

\_\_\_\_\_  
 Date                      Time                      Test Engineer                      QAE

## 6. TEST PROCEDURE FOR FSWINI\_005

### 6.1 Test Objective

This test verifies that EPU FSW performs a primary boot from RAD750 SUROM in response to EPU power-up. It also confirms that on power-up, the FSW initializes the RAM required to execute FSW applications and disables the watchdog for at least 5 minutes.

This Test Objective is broken down into the following Test Sub-Objectives.

Number	Test Sub-Objective
1	Verify that at least one primary boot image is burned into SUROM on the EPU0 RAD750 board and confirm that Primary Boot start from SUROM.
2	Confirm primary boot is complete after power up by verifying transmission of EPU0 boot housekeeping telemetry.

Number	Test Sub-Objective
3	Verify that the Virtual Spacecraft received the resulting memory dump in the EPU0 boot housekeeping telemetry.
4	Verify that FSW disables the watchdog of EPU0 for at least 5 minutes to ensure the hardware watchdog does not activate during the primary boot.
5	Verify that at least one primary boot image is burned into SUROM on the EPU1 RAD750 board and confirm that Primary Boot start from SUROM.
6	Confirm primary boot is complete after power up by verifying transmission of EPU1 boot housekeeping telemetry.
7	Verify that the Virtual Spacecraft received the resulting memory dump in the EPU1 boot housekeeping telemetry.
8	Verify that FSW disables the watchdog of EPU1 for at least 5 minutes to ensure the hardware watchdog does not activate during the primary boot.

## 6.2 Test Input Files

The following table identifies all auxiliary files (e.g., Front End Simulator data files, GLEAM data files) used as inputs to this qualification test. Note that not all qualification tests use input data of this type. The “Input File Version Number” column identifies the version number of the auxiliary file being used; alternatively, this column identifies the hardcopy attachment to this document that records the version of the file being used (e.g., “Attachment 1”). The “Path to Attachment” column specifies where in the test repository an electronic copy of the hardcopy attachment has been saved .

Input File	Description of Input File	Input File Version Number (or Specify Attachment Number)	Path to Attachment (If Applicable)
N/A	N/A	N/A	N/A

## 6.3 Test Preparation

After the hardware and software setup has been validated, steps may be required to place the hardware and FSW in an operational mode in which the qualification test can be performed or otherwise complete preparations for the test to begin.

The Test Engineer carries out the following procedure to prepare for qualification testing and records completion of the test preparation steps in the space provided.

Step No.	Description of Step	Step Outcome
1	Power up the VSC and SIU.	Complete/ Not Complete
2	Confirm that the EPU0 and EPU1 crates are ready to power up.	Complete/ Not Complete
3	Start CMX by issuing the following command from the host machine:  <b>\$ cmx start</b>	Complete/ Not Complete
4	On the host machine, change directory to the location of the test scripts by issuing the following command:  <b>\$ cd /afs/slac.stanford.edu/g/glast/flight/FST/source/FSWINI/Vx-x-x/FSWINI_005/</b>	Complete/ Not Complete

The Test Engineer and Quality Assurance Engineer verify that all test preparation steps are complete.

\_\_\_\_\_

Date

\_\_\_\_\_

Time

\_\_\_\_\_

Test Engineer

\_\_\_\_\_

QAE

## 6.4 Test Procedure

After the test setup has been validated, and test preparation steps are complete, the Test Engineer proceeds with the qualification test procedure itself, as described below, and records the outcome of each step during test execution. The outcome of each step is either “Complete” or “Not Complete” (for steps which involve no analysis or verification); or, “Pass” or “Fail” (for steps involved in verifying completion of test objectives and sub-objectives).

Step No.	Description of Step	Step Outcome
1	Power up the SIU.	Complete/ Not Complete
2	Run the FSWINI_005 test script by typing the following command at the shell:  <b>\$ ltx run &lt;FSWINI_005</b>  Mark ‘Complete’ for the Step Outcome if the test is not aborted.	Complete/ Not Complete

Step No.	Description of Step	Step Outcome
3	<p>LTX automatically sends several output files to the nfs file space. Print the /nfs/slac/g/glast/ltx000/ltx_repos/FST/FSWINI/Vx-x-x/FSWINI_0xx/mmdyy_hhmmss log file, retrieve it from the printer, label it, and attach it to this test procedure.</p> <p>Record the label written on the printed log file: _____</p> <p>Record the full nfs path and filename of the soft copy of this output file: _____</p>	Complete/ Not Complete
4	<p>The test script issues an LLIMLOADSHED command (all of LIM related commands will be tested in OPMODE). The SIU reboots the GASU, PDU, EPU, and instrument power.</p> <p>Then VSC issues the LLIMMAINFEEDON telecommand to power up the PDU and GASU and the LLIMPOWERON command to power up EPU0 and EPU1. In response to a power up, EPUs should begin a COLD primary boot.</p> <p>If the EPUs FSW cannot execute these operations, LTX prints an error message to the screen and exits, aborting the test.</p> <p>If the test is not aborted, mark 'Complete' for the Step Outcome.</p>	Complete/ Not Complete
5	<p>- Confirm that at least one primary boot image is burned into SUROM on the EPU0 RAD750 board. SUROM refers to the 256 kilobytes of EEPROM that reside on the RAD750. This EEPROM is NOT intended to be re-programmed during flight.</p> <p>The verification that FSW perform a primary boot from RAD750 SUROM is in the documentation that describes the RAD750 board hardware (BAE "RAD750 Board Appendix to the Hardware User's Manual"). The hardware gives the software no choice but to begin execution from the SUROM.</p> <p>The Storage and Interface Board (SIB) mounted in each CPU crate on the Testbed is labeled to indicate which boot image is loaded. When a new image is burned, the label is changed and the oslink is updated. This includes not only the version of the VXW package used to burn the image, but the FSW build as well.</p> <p>Read the label on the SIU SIB and record the version information:</p> <hr/> <p>Review the <b>xxx</b> output file and verify that the following entry appears:</p> <p style="text-align: center;"><b>FSWINI_005(1): Passed</b></p> <p>- To confirm that the PBC code continues to use the SUROM, send LMEMDUMPREG command with offset 0x8c. The value of this register is related to the CPU program counter, and should be in the SUROM range (0xff00000 - 0xff3fff).</p> <p>This is validation of requirement 5.3.1.2 for the EPU0. Those steps complete test sub-objective 1.</p>	Pass/Fail

Step No.	Description of Step	Step Outcome
6	<p>Review the <b>xxx</b> output file and verify that the following entry appears:</p> <p><b>FSWINI_005(2): Passed</b></p> <p>This output indicates that the EPU0 FSW performed a proper primary boot , at the end of which the FSW remained in the primary boot shell and transmitted boot housekeeping telemetry (LBTEPU0HKP packets) with APID = 0x261. Verify header and payload of boot housekeeping telemetry packets.</p> <p>This step completes test sub-objective 2.</p>	Pass/ Fail
7	<p>Review the <b>xxx</b> output file and verify that the following entry appears:</p> <p><b>FSWINI_005(3): Passed</b></p> <p>The PBC initializes RAM in two steps. First, the RAM that is tested right after reset is initialized as a side-effect of the testing. For cold boot, this is the entire RAM from address 0x00000000 to 0x00bffff. Second, the application/reserved RAM from 0x00c00000 to 0x07ffffff is initialized to all zeroes at the beginning of secondary boot.</p> <p>There's no way to access the RAM before the first step.</p> <p>Between the first step of RAM init and the second step when PBC is running:</p> <ul style="list-style-type: none"> <li>- Send LMEMLOADMEM command to the RAM above address 00c00000 (16 words) and 0x07ffffe0 (8 words) with random values;</li> <li>- Get uninitialized RAM using LMEMDUMPREG command ;</li> <li>- Reset the RAD750 with the primary boot flags set to re-run the RAM test (using the LPBCRESET command);</li> <li>- Look at RAM again after the PBC restarts.</li> </ul> <p>This output indicates that RAM initialization was performed correctly. After initialization, RAM word data should be all 0's.</p> <p>This step completes test sub-objective 3.</p>	Pass/ Fail
8	<p>After the previous steps of the test are complete, the test engineer waits for not less than 5 minutes to confirm that the EPU0 FSW remains the boot shell and is not restarted after 5 minutes by the hardware watchdog. The EPU0 boot housekeeping telemetry doesn't show the Hardware Watchdog Cold Reboot during 5 minutes after Primary Boot.</p> <p><b>FSWINI_005(4): Passed</b></p> <p>Another opportunity to trigger WATCHDOG is to send MEMLOADMEM command to the address 0xBF880058 with value 0 which initiates WATCHDOG type of reset. Resultant Boot Housekeeping Telemetry is checked to verify that the WATCHDOG type of reboot occurred in the BOOTYPE field. Also the Hi scrub addresses and error fields in this Telemetry are initialized too.</p> <p>This step completes test sub-objective 4.</p>	Pass/ Fail

Step No.	Description of Step	Step Outcome
9	<p>- Confirm that at least one primary boot image is burned into SUROM on the EPU1 RAD750 board. SUROM refers to the 256 kilobytes of EEPROM that reside on the RAD750. This EEPROM is NOT intended to be re-programmed during flight.</p> <p>The verification that FSW perform a primary boot from RAD750 SUROM is in the documentation that describes the RAD750 board hardware (BAE "RAD750 Board Appendix to the Hardware User's Manual"). The hardware gives the software no choice but to begin execution from the SUROM.</p> <p>The Storage and Interface Board (SIB) mounted in each CPU crate on the Testbed is labeled to indicate which boot image is loaded. When a new image is burned, the label is changed and the oslink is updated. This includes not only the version of the VXW package used to burn the image, but the FSW build as well.</p> <p>Read the label on the SIU SIB and record the version information:</p> <hr/> <p>Review the <b>xxx</b> output file and verify that the following entry appears:</p> <p><b>FSWINI_005(5): Passed</b></p> <p>- To confirm that the PBC code continues to use the SUROM, send LMEMDUMPREG command with offset 0x8c. The value of this register is related to the CPU program counter, and should be in the SUROM range (0xffff0000 - 0xffff3fff).</p> <p>This is validation of requirement 5.3.1.2 for the EPU1. Those steps complete test sub-objective 5.</p>	Pass/ Fail
10	<p>Review the <b>xxx</b> output file and verify that the following entry appears:</p> <p><b>FSWINI_005(6): Passed</b></p> <p>This output indicates that the EPU1 FSW performed a proper primary boot , at the end of which the FSW remained in the primary boot shell and transmitted boot housekeeping telemetry (LBTEPU1HKP packets) with APID = 0x262. Verify header and payload of boot housekeeping telemetry packets.</p> <p>This step completes test sub-objective 6.</p>	Pass/ Fail

Step No.	Description of Step	Step Outcome
11	<p>Review the <b>xxx</b> output file and verify that the following entry appears:</p> <p style="text-align: center;"><b>FSWINI_005(7): Passed</b></p> <p>The PBC initializes RAM in two steps. First, the RAM that is tested right after reset is initialized as a side-effect of the testing. For cold boot, this is the entire RAM from address 0x00000000 to 0x00bfffff. Second, the application/reserved RAM from 0x00c00000 to 0x07ffffff is initialized to all zeroes at the beginning of secondary boot.</p> <p>There's no way to access the RAM before the first step.</p> <p>Between the first step of RAM init and the second step when PBC is running:</p> <ul style="list-style-type: none"> <li>- Send LMEMLOADMEM command to the RAM above address 00c00000 (16 words) and 0x07ffffe0 (8 words) with random values;</li> <li>- Get uninitialized RAM using LMEMDUMPREG command ;</li> <li>- Reset the RAD750 with the primary boot flags set to re-run the RAM test (using the LPBCRESET command);</li> <li>- Look at RAM again after the PBC restarts.</li> </ul> <p>This output indicates that RAM initialization was performed correctly. After initialization, RAM word data should be all 0's.</p> <p>This step completes test sub-objective 7.</p>	Pass/ Fail
	<p>After the previous steps of the test are complete, the test engineer waits for not less than 5 minutes to confirm that the EPU1 FSW remains the boot shell and is not restarted after 5 minutes by the hardware watchdog. The EPU1 boot housekeeping telemetry doesn't show the Hardware Watchdog Cold Reboot during 5 minutes after Primary Boot.</p> <p style="text-align: center;"><b>FSWINI_005(8): Passed</b></p> <p>Another opportunity to trigger WATCHDOG is to send MEMLOADMEM command to the address 0xBF880058 with value 0 which initiates WATCHDOG type of reset. Resultant Boot Housekeeping Telemetry is checked to verify that the WATCHDOG type of reboot occurred in the BOOTYPE field. Also the Hi scrub addresses and error fields in this Telemetry are initialized too.</p> <p>This step completes test sub-objective 8.</p>	

Initial to confirm.

\_\_\_\_\_  
 Date                      Time                      Test Engineer                      QAE

**7. TEST POST-CONDITIONS AND OVERALL OUTCOME**

**7.1 Test Post-Conditions**

The expected state of the FSW and/or Testbed at the conclusion of this qualification test is indicated in the following table.

No.	Post-Condition	Post-Condition Met? (Yes/No)
1	Primary boot is complete and the EPU's are ready for the secondary boot process.	

The Test Engineer and Quality Assurance Engineer verify that all test post-conditions are met.

\_\_\_\_\_  
 Date                      Time                      Test Engineer                      QAE

**7.2 Overall Outcome of FSWINI\_005**

Based on the analysis of the test results, the overall outcome of Test FSWINI\_005 is as follows:

- Passed** - all of the expected outcomes for the test were confirmed
- Failed** - one or more of the test outcomes were not confirmed

\_\_\_\_\_  
 Date                      Test Engineer                      QAE

**8. CERTIFICATION**

I certify that the information obtained under this test procedure is as represented and the information recorded in this document is complete and correct. Any deviations from test procedures described herein are identified in Appendix A.

\_\_\_\_\_  
Date                                      Test Engineer (Print Name)                                      Test Engineer (Signature)

I certify that the information obtained through execution of this test procedure is as represented and the information recorded in this document is complete and correct. Execution of the test, storage of the results, and verification of outcomes were carried out in accordance with quality standards defined in the GLAST Quality Manual (LAT-MD-00091).

\_\_\_\_\_  
Date                                      Software QA Engineer (Print Name)                                      Software QA Engineer (Sign)

I certify that the information obtained under this test procedure is as represented and the information recorded in this document is complete and correct. The test procedure, as designed and executed, does indeed verify that the FSW functionality under test satisfies the corresponding requirements from the Flight Software Specification – Level III.

\_\_\_\_\_  
Date                                      FSW Manager (Print Name)                                      FSW Manager (Signature)

---

**APPENDIX A: DEVIATIONS FROM THE QUALIFICATION TEST PROCEDURE**

This section details any deviations from the hardware configuration, software configuration, or test procedure followed during the execution of the test or tests described in this Qualification Test Procedure document. All deviations from the approved procedure are agreed to by the Test Engineer and the Software Quality Engineer during the test execution session. All deviations must be reported during the Post Qualification Test Review, where their impact on the test results will be evaluated.

**Hardware Deviations**

Describe any deviations from the hardware configuration defined in Section 5.1. Name the hardware that was modified and describe the modifications. If hardware is *replaced* during execution of the test, name the replaced hardware, the manufacturer, and list an identification number (e.g., GLAT ID number).

---

---

---

---

---

---

---

---

**Software Deviations**

Describe any changes made to the software configuration under test or the software configuration used to support test execution, as defined in Section 5.2. Give version numbers of all FSW packages and test packages that were modified. Describe how the contents of the modified software load were verified. Describe these deviations for each test that was modified.

---

---

---

---

---

---

---

---

---

**Procedural Deviations**

Specify any deviations from the test procedure for the test being executed. If this document contains more than one test procedure, list the procedure by number (e.g., “MEMMGT\_001”). List by number the steps modified or skipped. Provide a numbered sequence listing any added steps. Describe these deviations for each test that was modified.

---

---

---

---

---

---

---