



DCN No.
LAT-XR-07131-01

LAT PROJECT DOCUMENT CHANGE NOTICE (DCN)

SHEET 1 OF 2

ORIGINATOR: Mike DeKlotz **PHONE:** 650-926-4752 **DATE:** 8/16/05

CHANGE TITLE: DCN for LAT Flight Software Test Procedures **ORG.:**

DOCUMENT NUMBER	TITLE	NEW REV.
LAT-TD-07126	LAT FSW Qualification Test Procedure: DCMODE_001: ACD Diagnostics & Calibration	01
LAT-TD-07127	LAT FSW Qualification Test Procedure: DCMODE_002: ACD Diagnostics & Calibration	01
LAT-TD-07128	LAT FSW Qualification Test Procedure: DCMODE_003: TKR Diagnostics & Calibration	01
LAT-TD-07129	LAT FSW Qualification Test Procedure: NBTLMV_001: Narrowband Telemetry Housekeeping & Low-rate Science Data Verificaiton	01
LAT-TD-07130	LAT FSW Qualification Test Procedure: NBTLMV_002: Diagnostic Telemetry Verification	01

CHANGE DESCRIPTION (FROM/TO):

LAT-TD-07132-01- LAT FSW Qualification Test Procedure: FSWINI_001: FSW Initialization-SIU Primary Boot
 LAT-TD-07133-01- LAT FSW Qualification Test Procedure: FSWINI_002: FSW & LAT Initialization- Boot Self-Test & Boot Housekeeping Telemetry
 LAT-TD-07134-01- LAT FSW Qualification Test Procedure: FSWINI_003: FSW & LAT Initialization- Multiple Boot Images
 LAT-TD-07135-01- LAT FSW Qualification Test Procedure: FSWINI_004: FSW & LAT Initialization- SIU Hardware Reboot in response to the Signal on the Discrete Lines
 LAT-TD-07136-01- LAT FSW Qualification Test Procedure: FSWINI_005: FSW Initialization- EPU Primary Boot
 LAT-TD-07137-01- LAT FSW Qualification Test Procedure: FSWINI_006: FSW & LAT initialization- Reset Source
 LAT-TD-07138-01- LAT FSW Qualification Test Procedure: FSWINI_007: FSW & LAT Initialization- Storage & Retrieval of System Errors During SIU Primary Boot
 LAT-TD-07139-01- LAT FSW Qualification Test Procedure: FSWINI_008: FSW & LAT Initialization- Storage & Retrieval of System Errors During EPU Primary Boot
 LAT-TD-07140-01- LAT FSW Qualification Test Procedure: FSWINI_009: FSW & LAT Initialization- SIU Boot Status on Discrete Lines & SISU Boot Housekeeping Telemetry
 LAT-TD-07141-01- LAT FSW Qualification Test Procedure: FSWINI_010: FSW & LAT Initialization- SIU & EPU Secondary Boot
 LAT-TD-07142-01- LAT FSW Qualification Test Procedure: FSWINI_011: FSW & LAT Initialization- SIU & EPU Secondary Boot Error Mitigation
 LAT-TD-07143-01- LAT FSW Qualification Test Procedure: FSWINI_012: FSW & LAT Initialization- LAT SEU Protection
 LAT-TD-07144-01- LAT FSW Qualification Test Procedure: FSWINI_013: FSW & LAT Initialization- LAT Memory Scrubbing
 LAT-TD-07145-01- LAT FSW Qualification Test Procedure: FSWINI_014: FSW & LAT Initialization- Watchdog Management During Boot
 LAT-TD-07146-01- LAT FSW Qualification Test Procedure: FSWINI_015: FSW & LAT Initialization- Soft Reset
 LAT-TD-07152-01 - LAT FSW Qualification Test Procedure:FECALB_001: Charge Injection Calibration – TOT Measurements
 LAT-TD-07153-01- LAT FSW Qualification Test Procedure:FECALB_002: Charge Injection Calibration – TKR Threshold and Charge Scans
 LAT-TD-07154-01- LAT FSW Qualification Test Procedure: FECALB_003: Charge Injection Calibration – TKR Trigger Check
 LAT-TD-07155-01- LAT FSW Qualification Test Procedure: FECALB_004: Charge Injection Calibration – ACD Charge Injection
 LAT-TD-07156-01- LAT FSW Qualification Test Procedure: FECALB_005: Charge Injection Calibration – CAL Charge Injection
 LAT-TD-07157-01- LAT FSW Qualification Test Procedure: WBTLMV_001: Wideband Telemetry Verification – Science Data Format and Volume

REASON FOR CHANGE:

ACTION TAKEN: Change(s) included in new release DCN attached to document(s), changes to be included in next revision
 Other (specify):

DISPOSITION OF HARDWARE (IDENTIFY SERIAL NUMBERS):	DCN DISTRIBUTION:
<input checked="" type="checkbox"/> No hardware affected (record change only)	
<input type="checkbox"/> List S/Ns which comply already:	
<input type="checkbox"/> List S/Ns to be reworked or scrapped:	
<input type="checkbox"/> List S/Ns to be built with this change:	
<input type="checkbox"/> List S/Ns to be retested per this change:	
<input type="checkbox"/>	

SAFETY, COST, SCHEDULE, REQUIREMENTS IMPACT? YES NO
 If yes, CCB approval is required. Enter change request number:

APPROVALS	DATE	OTHER APPROVALS (specify):	DATE
ORIGINATOR: M. DeKlotz (signature on file)	8/16/05		
ORG. MANAGER: D. Horn (signature on file)	8/16/05		
PSA- K. Burlingham (signature on file)	8/16/05		
DCC RELEASE: Natalie Cramar (signature on file)	8/16/05	Doc. Control Level: <input checked="" type="checkbox"/> Subsystem <input type="checkbox"/> LAT IPO <input type="checkbox"/> GLAST Project	

DCN No: LAT-XR-07131-01



DCN No.
LAT-XR-07131-01

LAT PROJECT DOCUMENT CHANGE NOTICE

SHEET 2 OF 2

Continuation:

LAT-TD-07158-01- LAT FSW Qualification Test Procedure: FILMGT_001: File Management Verification
LAT-TD-07159-01- LAT FSW Qualification Test Procedure: MEMMGT_002: Memory Load Data
LAT-TD-07160-01- LAT FSW Qualification Test Procedure: NBTLMV_003: ACD HSK Anomaly Response and Alert Telemetry Verification
LAT-TD-07161-01- LAT FSW Qualification Test Procedure: OPMODE_001: LAT Operational Mode Control
LAT-TD-07162-01- LAT FSW Qualification Test Procedure: THRMCS_001: LAT Thermal Control System
LAT-TD-07163-01- LAT FSW Qualification Test Procedure: VSGIFV_001: Discrete Signal Interfaces
LAT-TD-07164-01- LAT FSW Qualification Test Procedure: CMDFNC_003: 1553 Interface and Command Functional Verification
LAT-TD-07054-01- LAT FSW Qualification Test Procedure: EVTPMO_001: Event Performance Monitoring and Verification – Software-Related Deadtime
LAT-TD-07055-01- LAT FSW Qualification Test Procedure: EVTPMO_002: Event Performance Monitoring and Verification –Acquisition of VETO Rates from the GEM
LAT-TD-07056-01- LAT FSW Qualification Test Procedure: EVTPMO_003: Event Performance Monitoring and Verification – Level 1 Trigger Rates
LAT-TD-07057-01- LAT FSW Qualification Test Procedure: EVTPMO_004: Event Performance Monitoring and Verification – Monitor CNO Rates
LAT-TD-07112-01- LAT FSW Qualification Test Procedure: EVTFIL_001: Event Filtering – Interface from the Event Builder
LAT-TD-07113-01- LAT FSW Qualification Test Procedure: EVTFIL_002: Event Filtering – Event Filter Rates and Capacity
LAT-TD-07114-01- LAT FSW Qualification Test Procedure: EVTFIL_003: Event Filtering – Event Filter Reprogramming
LAT-TD-07115-01- LAT FSW Qualification Test Procedure: EVTFIL_004: Event Filtering – Event Filter Bypass

	Document # LAT-TD-07113	Date effective
	Author(s) Igor Volobouev Mark Arndt	Supersedes
	Subsystem/Office Electronics & DAQ Subsystem	
Document Title LAT FSW Qualification Test Procedure: EVTFIL_002: Event Filtering – Event Filter Rates and Capacity		

CHANGE HISTORY LOG

Revision	Effective Date	Description of Changes
01	08/15/05	Original

TABLE OF CONTENTS

1.Scope.....	4
1.1Test Suite.....	4
1.2Test ID.....	4
1.3Requirement(s) Tested.....	4
2.DEFINITIONS AND ACRONYMS.....	5
2.1Definitions.....	5
2.2Acronyms.....	5
3.REFERENCES.....	6
3.1Applicable Documents.....	6
4.REQUIREMENTS.....	7
4.1Test Data, Equipment and Software.....	7
4.2Quality Assurance.....	7
4.3Safety.....	7
4.4Warnings, Cautions, and Notes.....	8
4.5General Instructions.....	8
5.SETUP.....	9
5.1Hardware Setup.....	9
5.2Software Setup.....	10
5.3Setup Validation.....	12
6.TEST PROCEDURE FOR EVTFIL_002.....	13
6.1Test Objective.....	13
6.2Test Input Files.....	14
6.3Test Output Files.....	14
6.4Test Preparation.....	15
6.5Test Procedure.....	15
7.TEST POST-CONDITIONS AND OVERALL OUTCOME.....	16
7.1Test Post-Conditions.....	16
7.2Overall Outcome of EVTFIL_002.....	17
8.CERTIFICATION.....	18

1.SCOPE

This document describes the procedure followed for qualification testing of the LAT FSW. This Qualification Test Procedure document describes one of the qualification tests executed to verify compliance with the requirements defined in the “Flight Software Specification – Level III” (LAT-SS-00399).

1.1 Test Suite

EVTFIL

The Test Suite is a logical grouping of a set of tests based on common functionalities and can be executed as a suite of tests in some order when the pre-conditions and post-conditions for each test within the suite have been met successfully.

This test procedure *EVTFIL_002* belongs in the Test Suite *EVTFIL* under the *FST* Project. The *EVTFIL* tests verify the functionality of the LAT onboard event filter software.

1.2 Test ID

EVTFIL_002

Test *EVTFIL_002* contains one main test script, *evtfil_002.py*, which can be run when the SIU and EPU are operating in Application Mode.

1.3 Requirement(s) Tested

The Qualification Test Procedure described herein is performed to verify that the FSW satisfies the following requirement(s), quoted from the Flight Software Specification – Level III:

Requirement Number	Requirement Name	Requirement
5.3.9.1	Event Filter Rates and Capacity	<p>The FSW shall provide the capability to filter the input stream of events accepted by the electronic trigger to an output stream commensurate with the spacecraft (SC) interface rate (see 5.2.1.3.1), and capacity of a maximum of 104 Gb in any given 24 hour period, keeping events meeting the science objectives.</p> <p>Note that the 104 Gb allocation includes a total source packet overhead of 112 bits per packet (64 bits of the secondary header are for a time stamp).</p>

If the requirement(s) quoted above cite external documents (e.g., “...Further details are provided in [11]”), consult LAT-SS-00399 for the list of citations.

2.DEFINITIONS AND ACRONYMS

The following terms, abbreviations, and acronyms are used in this document:

2.1Definitions

Hz	Hertz, unit of frequency
s, sec	seconds
V	Volt
W	Watt
s, sec	seconds

2.2Acronyms

CAL	Calorimeter
EGSE	Electrical Ground Support Equipment
FOV	Field of View
GASU	Global trigger Anti-collision Spacecraft Unit
GBM	Gamma-ray Burst Monitor
GRB	Gamma Ray Bust
PTR	Post Test Review
TEM	Tower Electronics Module
TKR	Tracker
TPS	Tower Power Supply
TRR	Test Readiness Review
QAE	Quality Assurance Engineer
TE	Test Engineer
BPU	Bus Protection Unit
APID	Application Identifier
FES	Front-End Simulator
VSC	Virtual Spacecraft
LIM	LAT Instrument Manager
LPA	LAT Physics Application
SIU	Spacecraft Interface Unit

3.REFERENCES

The list below provides documents that are to be used as references for this procedure:

3.1Applicable Documents

<u>Document Number</u>	<u>Description</u>
<u>SPECIFICATIONS</u>	
LAT-SS-00399	LAT Flight Software Level III Specification
1196 EI-S46310-000	GLAST 1553 Bus Protocol Interface Control
LAT-TD-02659	LAT Flight Software Telecommand and Telemetry Formats
LAT-TD-0561	The Virtual Spacecraft (VSC)
LAT-SS-00010-1	GLAST LAT Performance Specification - Level II(b) Specification
<u>PROCEDURES</u>	
<u>PLANS</u>	
LAT-MD-00039	Performance Assurance Implementation Plan
LAT-MD-00078	GLAST LAT System Safety Program Plan
LAT-MD-00404	LAT Contamination Control Plan
LAT-MD-00408	LAT Program Instrument Performance Verification Plan
LAT-SS-00296	T & DF Test Plan
LAT-TD-00297	LAT Electronics Test Plan
LAT-TD-00786	LAT Flight Software Test Plan
LAT-MD-00104	LAT Flight Software Management Plan
<u>DRAWINGS</u>	
<u>OTHER</u>	
LAT-MD-00091	GLAST Quality Manual
LAT-MD-00471	Control of Nonconforming Product
LAT-MD-00472	Corrective and Preventative Action

4.REQUIREMENTS

This section lists the requirements that shall be followed during the LAT FSW Qualification Testing process.

The Performance Assurance Implementation Plan, LAT-MD-00039, shall be utilized to ensure that the products produced by the GLAST LAT project intended for design qualification, flight and critical ground support equipment usage meet the required levels of quality and functionality for their intended purposes.

The LAT Program Instrument Performance Verification Plan, LAT-MD-00408, shall be utilized to address the testing to be performed at the unit/subsystem and instrument level for flight qualification, proto-flight and acceptance testing phases. Also included are the necessary processes/procedures and systems assurance activities.

4.1 Test Data, Equipment and Software

This procedure shall follow the requirements found in the Control of Nonconforming Product, LAT-MD-00471. This document establishes the method to identify and control nonconforming product developed by the LAT project team.

4.2 Quality Assurance

This procedure shall follow the requirements found in the Corrective and Preventative Action document, LAT-MD-00472 and the GLAST Quality Manual, LAT-MD-00091.

The Corrective and Preventative Action document establishes the method to be used to initiate, implement, evaluate and record corrective and preventive actions. The GLAST Quality Manual defines the methods implemented by the GLAST LAT project to ensure consistent quality of all processes for procurement, design, development and production of flight hardware, flight software and all associated ground support equipment interfacing with flight hardware and software.

4.3 Safety

This procedure shall follow the requirements found in the GLAST LAT System Safety Program Plan, LAT-MD-00078. This document defines all phases of the LAT program including: design, development, fabrication, handling, transportation, storage, test, assembly and operation.

WARNING:When high voltages are present extreme care should be exercised.

4.4 Warnings, Cautions, and Notes

The following SAFETY ALERTS are intended to create awareness of the potential safety hazards and the steps that must be taken to avoid accidents. These same alerts are used throughout this document to identify specific hazards that may endanger personnel and/or equipment.

Identification of every conceivable hazardous situation is impossible. Therefore, all personnel have the responsibility to diligently exercise safe practices whenever exposed to this equipment.

WARNING: Indicates a potential hazardous situation which, if not avoided, could result in death or injury.

CAUTION: Indicates a potential hazardous situation which, if not avoided, could result in damage to equipment.

Note: Indicates a notification of information that is important, but not hazard related.

4.5 General Instructions

This qualification test procedure shall be conducted on a formal basis to its latest approved and released version. The designated Software QAE shall be notified 24 hours prior to the start of this procedure. Software QAE may monitor the execution of all or part of this procedure should they elect to do so.

The Test Engineer conducting this test shall read this document in its entirety and resolve any apparent ambiguities before beginning the procedures described herein.

Deviations from the procedures described in this document and breaks in hardware or software configuration can only be initiated by the Test Engineer, must be approved by QA, and must be documented in Appendix A.

Any nonconformance/defect/anomaly is to be reported in JIRA. Refer to the LAT Flight Software Test Plan LAT-TD-00786 for guidance. Do not alter or break configuration if a failure occurs. Notify Software Quality Assurance.

All success conditions for a test must be met for the test to pass.

5.SETUP

This section describes the hardware and software configuration used for the qualification test described later in this document. Any break from configuration or deviation from a particular procedure must be authorized by the Quality Assurance Engineer and documented in Appendix A.

5.1Hardware Setup

The list below indicates the equipment that is used to execute the tests described in this document.

Hardware Unit	Manufacturer	GLAT Number	Firmware Version (where applicable)
Front End Simulator (FES): 1	SLAC		
Virtual Spacecraft (VSC): 1	SLAC		
Spacecraft Interface Unit (SIU): 1	SLAC		
Event Processing Unit (EPU): 2	SLAC		
Tower Electronics Module (TEM): 16	SLAC		
Global Trigger AEM Signal distribution unit (GASU): 1	SLAC		
Power Distribution Unit (PDU):1	SLAC		
Unix or Linux host Establishes connection between VSC and the terminal from which the test is run.			

The Figure below depicts the Testbed on which this qualification test is performed. The particular hardware units utilized in this test are itemized by GLAT number and firmware version in the preceding table.

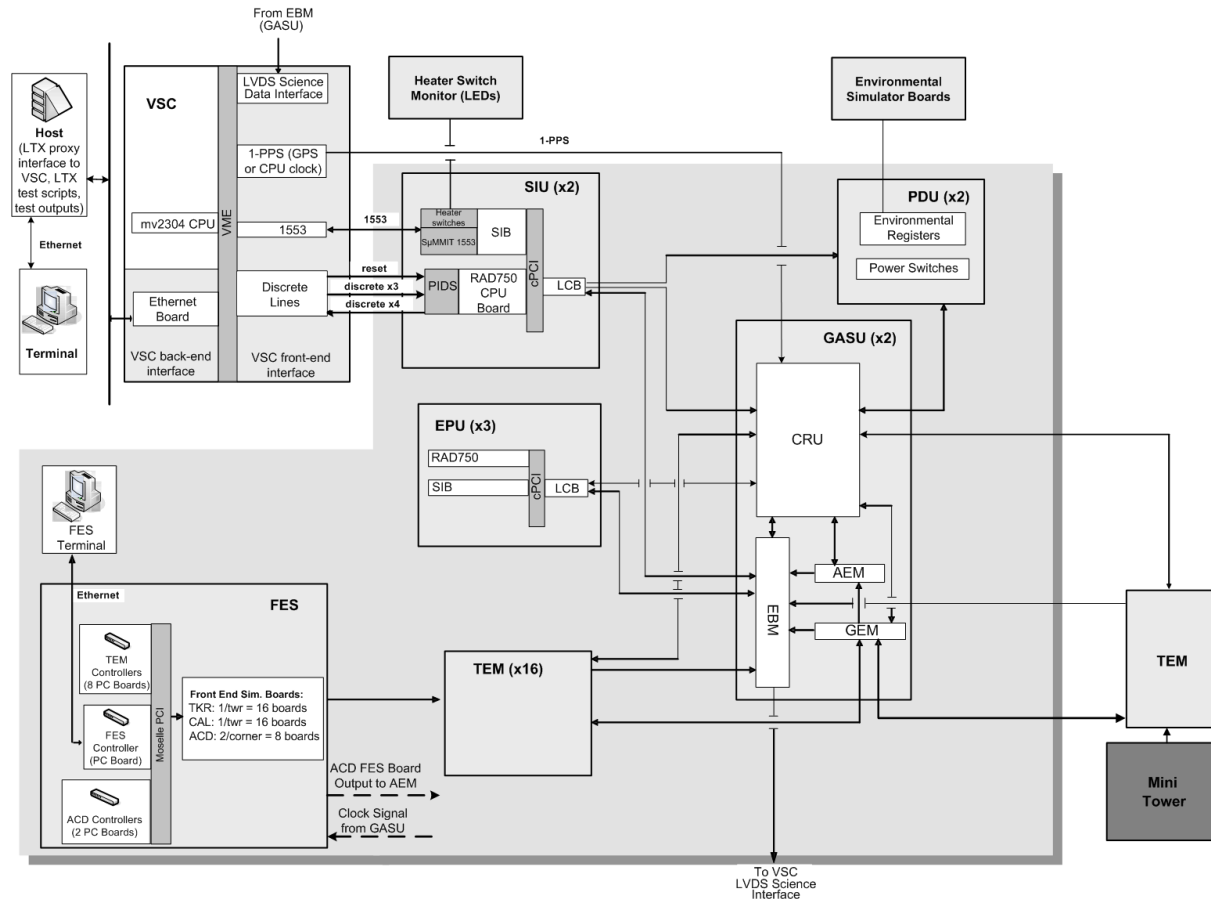

Figure 1. FSW Testbed

5.2 Software Setup

The software required to prepare for and execute the tests described in this Qualification Test Procedure document is itemized in this section.

5.2.1 Test Tools

The following table specifies the test executive used to run this qualification test, and identifies the other software tools used to support the execution of the test. The “Software Version Number” column identifies the version number of the test tool being used; alternatively, this column identifies the hardcopy attachment to this document that records the version of the tool being used (e.g., “Attachment 1”). The “Path to Attachment” column identifies the directory in which the electronic copy of any hardcopy attachment is saved (if applicable).

Software	Description of Software	Software Version Number (or Specify Attachment Number)	Path to Attachment (If Applicable)
LTX	LAT Test Executive		
FMX	File Management Extra		

Software	Description of Software	Software Version Number (or Specify Attachment Number)	Path to Attachment (If Applicable)
GLEAM	GLast Event Analysis Machine		
FES	Front End Simulator system software		
VSC	Virtual Spacecraft system software		
VPI	VSC Python/Proxy Interface		
(GLAST) ROOT	Data analysis toolkit		

5.2.2 Test Scripts

The following table identifies the test scripts that are run to execute this qualification test. The “Script Version Number” column identifies which version of the script is being used; alternatively, this column identifies the hardcopy attachment to this document that records the version of the script being used (e.g., “Attachment 1”). The “Path to Attachment” column identifies the directory in which the electronic copy of any hardcopy attachment is saved (if applicable).

Test Script	Description of Test Script	Script Version Number (or Specify Attachment Number)	Path to Attachment (If Applicable)
evtfil_002.py	Main LTX qualification test execution script for EVTFIL_002		
evtfil_002.xml	LTX test description file for EVTFIL_002		
evtfil_002_analyze.py	Test data/results analysis script for EVTFIL_002		

5.2.3 Flight Software

This qualification test is performed on a complete, integrated Candidate Release of FSW. All FSW libraries under test are final Flight Unit Candidate versions. The test described in this document is designed to evaluate the particular FSW packages and constituents listed in the following table; for clarity, only those constituents that are the focus of the test are listed below.

FSW Package	Constituent(s)
EFC	TBD

The Candidate Release into which these FSW constituents are integrated is identified in the following table. The “Candidate Release Build Number” column specifies the build number of the

FSW Candidate Release under test (e.g., “B0-0-1”). The “Candidate Release Attachment Number” column identifies which hardcopy attachment to this document confirms the name and version number of the full set of FSW packages and constituents used in the test (e.g., “Attachment 2”). The “Path to Attachment” column specifies where in the test repository an electronic copy of the hardcopy attachment has been saved.

Candidate Release Build Number	Candidate Release Attachment Number	Path to Attachment

5.3 Setup Validation

5.3.1 Hardware Validation

The following signatures confirm that the Test Engineer and Quality Assurance Engineer have verified the GLAT numbers, firmware version numbers, and the proper connection of all hardware listed in the table in Section 5.1.

 Date Time Test Engineer QAE

5.3.2 Software Validation

The Test Engineer performs the following procedure to validate the software setup for this qualification test and records completion of the setup validation steps in the space provided.

Step No.	Description of Step	Step Outcome
1	Obtain version numbers of the test tools used to perform this qualification test by running the TBD script. Pick up and label the hardcopy report generated by the TBD script and attach it to this test procedure document. Record (1) the label for the attachment and (2) the directory location to which an electronic copy of the report was saved in Section 5.2.1.	Complete/ Not Complete
2	Obtain version numbers of the test scripts used to perform this qualification test by running the TBD script. Pick up and label the hardcopy report generated by the TBD script and attach it to this test procedure document. Record (1) the label for the attachment and (2) the directory location to which an electronic copy of the report was saved in Section 5.2.2.	Complete/ Not Complete
3	Obtain the versions of the FSW packages loaded on the targets by running the version_test script in the Application Mode . Pick up and label the hardcopy report generated by the version_test script and attach it to this test procedure document. Record (1) the label for the attachment and (2) the directory location to which an electronic copy of the report was saved in Section 5.2.3.	Complete/ Not Complete

The following signatures confirm that, using the procedure described in the previous table, the Test Engineer and Quality Assurance Engineer have verified that all versions of test support software, test scripts, and FSW constituents match those identified in Section 5.2.

_____ Date

_____ Time

_____ Test Engineer

_____ QAE

6.TEST PROCEDURE FOR EVTFIL_002

6.1Test Objective

This test verifies that:

- The output rate of the filtered events is compatible with the spacecraft interface rate of 40 Mbps
- The filter can be configured so that the event stream does not exceed the spacecraft capacity of 104 Gb in any 24 hour period. This test assumes that the actual data volume management policy will be left to the ground operations, and only verifies that the flight software provides sufficient support for implementing such a policy.
- The trigger keeps events consistent with the LAT science objectives. These objectives are specified in the LAT Performance Specification document LAT-SS-00010-1. Objectives relevant to this test are:
 - The effective area for 20 MeV photons at normal incidence should exceed 300 cm²
 - The effective area for 100 MeV photons at normal incidence should exceed 3000 cm²
 - The effective area for 300 GeV photons at normal incidence should exceed 6400 cm²
 - The peak effective area at optimal energy should exceed 8000 cm²
 - The LAT field of view should exceed 2 steradians

The test runs several sets of simulated science data through the Front End Simulator and monitors the FSW performance while the simulations are running.

This Test Objective is broken down into the following Test Sub-Objective(s).

Number	Test Sub-Objective
1	Using simulated photon data with different energies, the test confirms that the fraction of photon events passed by the filter satisfies the effective area and the field of view requirements.
2	The test uses the peak rate and size of passed background events at the orbit interval with high expected background to verify the interface rate requirement.

Number	Test Sub-Objective
3	The test verifies that the filter can be reconfigured to reduce the rate of passed events in order to comply with the data volume requirement. Two alternative configuration are used: with tightened event selection criteria and with filter configured to reject all events.

6.2 Test Input Files

The following table identifies all auxiliary files (e.g., Front End Simulator data files, GLEAM data files) used as inputs to this qualification test. Note that not all qualification tests use input data of this type. The “Input File Version Number” column identifies the version number of the auxiliary file being used; alternatively, this column identifies the hardcopy attachment to this document that records the version of the file being used (e.g., “Attachment 1”). The “Path to Attachment” column specifies where in the test repository an electronic copy of the hardcopy attachment has been saved .

Input File	Description of Input File	Input File Version Number (or Specify Attachmnt Number)	Path to Attachment (If Applicable)
TBD	Simulated orbit file for high background orbit		
TBD	FES file simulating cosmic ray background data on high background orbit		
TBD	FES file simulating 20 MeV photons		
TBD	FES file simulating 100 MeV photons		
TBD	FES file simulating 300 GeV photons		
TBD	FES file simulating 1/E photon spectrum at normal incidence		
TBD	FES file simulating 1/E photon spectrum with isotropic flux from the zenith hemisphere		
TBD	Filter configuration file with default event selection criteria		
TBD	Filter configuration file with tightened event selection criteria		
TBD	Filter configuration for rejecting all events		

6.3 Test Output Files

The following table identifies the log files, data dump files, and other output files generated by the test scripts executed during this qualification test. The “Output File Attachment Number” column identifies which attachment to this document is the hardcopy record of this script output data. The

“Path to Attachment” column specifies where in the test repository an electronic copy of the hardcopy attachment has been saved.

Output File	Description of Output File	Output File Attachment Number	Path to Attachment
TBD	Science data telemetry, LDF format file for the 20 MeV photon sample		
TBD	Science data telemetry, LDF format file for the 100 MeV photon sample		
TBD	Science data telemetry, LDF format file for the 300 GeV photon sample		
TBD	Science data telemetry, LDF format file for the 1/E normal incidence photon sample		
TBD	Science data telemetry, LDF format file for the 1/E isotropic incidence photon sample		
TBD	Science data telemetry, LDF format file for the background run with the standard filter configuration		
TBD	Science data telemetry, LDF format file for the background run with tightened event selection criteria		
TBD	Science data telemetry, LDF format file for the run in which the filter is configured to reject all events		
TBD	Analysis script output		

6.4 Test Preparation

After the hardware and software setup has been validated, steps may be required to place the hardware and FSW in an operational mode in which the qualification test can be performed or otherwise complete preparations for the test to begin.

The Test Engineer carries out the following procedure to prepare for qualification tested and records completion of the test preparation steps in the space provided.

Step No.	Description of Step	Step Outcome
1	Confirm that the Front End Simulator is powered up: -- The power LED on all FES computers (lat-ent1, lat-ent2, ..., lat-ent11) should be on. -- The voltage indicator on the Xantrex power supply marked "FES-FEED" should display $48 \pm 0.5V$, and the current should be above 5A. -- The state indicators on all FES electronic boards should be flashing.	Complete/ Not Complete
2	Boot the Front End Simulator control nodes.	Complete/ Not Complete

Step No.	Description of Step	Step Outcome
3	Load simulated science data files to the FES nodes.	Complete/ Not Complete
4	Boot and initialize the Virtual Spacecraft.	Complete/ Not Complete
5	Confirm that the SIU and the GASU are powered up: -- The voltage indicator on the SIU/GASU Xantrex power supply should display $28 \pm 0.2V$. -- The SIU feed "POWER ON" switch on the regulated feeds bus protection unit (BPU) should be flipped "ON". The SIU voltage indicator on the BPU should display $28 \pm 0.2V$. The SIU current as shown by the BPU indicator should be above 0.4A -- The DAQ feed "POWER ON" switch on the BPU should be flipped "ON". The DAQ voltage indicator on the BPU should display $28 \pm 0.2V$.	Complete/ Not Complete
6	Execute Primary Boot and Secondary Boot on the SIU crate.	Complete/ Not Complete
7	Execute Primary Boot and Secondary Boot on the EPU crates.	Complete/ Not Complete
8	Confirm that FSW application modules have been loaded and that all FSW tasks have been initialized and are running. [[A script will be provided for this purpose.]]	Complete/ Not Complete

The Test Engineer and Quality Assurance Engineer verify that all test preparation steps are complete.

Date

Time

Test Engineer

QAE

6.5 Test Procedure

After the test setup has been validated, and test preparation steps are complete, the Test Engineer proceeds with the qualification test procedure itself, as described below, and records the outcome of each step during test execution. The outcome of each step is either "Complete" or "Not Complete" (for steps which involve no analysis or verification); or, "Pass" or "Fail" (for steps involved in verifying completion of test objectives and sub-objectives).

Step No.	Description of Step	Step Outcome
1	Verify presence of the simulated science data on the FES nodes: [[Will be implemented using Owen Saxton's FES web server at http://lat-ent1/home.asp Support for file system browsing is not there yet.]]	Complete / Not Complete
2	Verify that the filter configuration files listed in Section 6.2 are present on the SIB EEPROM and that they are included into the LPA task "working set". [[A script will be provided for this purpose.]]	Complete / Not Complete

Step No.	Description of Step	Step Outcome
3	<p>Launch the data acquisition script. The expected run time for this script is TBD min:</p> <p>Itx run EVTFIL_002</p> <p>The data acquisition script performs eight testbed runs using different Monte Carlo event samples and onboard filter configurations and generates eight LDF files listed in the table in Section 6.3. The following sequence of operations is performed for each testbed run:</p> <ol style="list-style-type: none"> 1) A set of spacecraft timestamped coordinates and attitudes is scheduled for simulation on the VSC using the VSC interface M7 (“magic seven”) class. The simulated orbit file used for “magic seven” telecommand scheduling is the same as the orbit file used to produce the background simulation. The orbit file format is described at http://confluence.slac.stanford.edu/display/DC2/Orbit+and+Pointing+History 2) The science telemetry stream is open on the VSC (operation description TBD). 3) The Physics-Start telecommand (APID TBD) is sent to the spacecraft. This changes the LAT Instrument Manager operation mode from QUIESCENT to PHYSICS and initiates data taking by the LAT. The filter configuration number (an element of the LPA “working set”) is provided as the telecommand argument. 4) The LLIMSTATE telemetry (APID 0x30f) is received. The LPA task state, as identified by the lpa_state field, is required to be “Running”. The LIM operation mode, as identified by the op_mode field, is required to be PHYSICS. The timeout for LLIMSTATE telemetry reception after the Physics-Start telecommand is set to TBD seconds. 5) The FES run is started using the VSC interface FES class “start” method. FES timing is periodic for the runs with photon samples and determined by simulation for the runs with the background sample. 6) After a waiting period, the FES run is stopped using the VSC interface FES class “stop” method. For the photon samples, the length of the waiting period is set to the number of events in the sample times the FES period. For the background samples the length of the waiting period is determined by the difference in the time of the first and last event in the sample. 7) The Physics-Stop telecommand (APID TBD) is sent to the spacecraft. 8) One or more LLIMSTATE telemetry packets is received, until the lpa_state field of the LLIMSTATE packet indicates that that the state of the LPA task is “Idle” and the op_mode field indicates that the instrument operation mode is QUIESCENT. The timeout for telemetry reception after the Physics-Stop telecommand is set to TBD seconds. 9) The science telemetry stream is closed on the VSC (operation description TBD). 	<p>Complete / Not Complete</p>

Step No.	Description of Step	Step Outcome
4	<p>Run the data analysis script. The expected run time for this script is TBD min:</p> <p>python \$HOME/FST/source/EVTFIL/test/EVTFIL_002/evtfil_002_analyze.py TBD</p> <p>For the fixed energy photon samples, the data analysis script determines the effective area, A_{eff}, as</p> $A_{eff} = N_{pass}/N_{gen} A_{flux}$ <p>where</p> <p>N_{pass} is the number of photon events which passed the on-board filter and were delivered on the VSC science stream</p> <p>N_{gen} is the number of photon events originally generated in Monte Carlo for this energy (before trigger)</p> <p>A_{flux} is the area over which the photon flux was generated (6 m² for all Monte Carlo event samples)</p> <p>The peak effective area is determined from the 1/E normal incidence photon sample. A sliding window with width TBD and step TBD is used in the $\log_{10}(E / 1 \text{ MeV})$ variable. The number of generated MC events inside the sliding window is assumed to be the same for each window position and determined as</p> $N_{gen} = N_{all} (\text{window width}) / \log_{10}(E_{max}/E_{min})$ <p>where</p> <p>E_{min} is the minimum photon energy in the simulation (20 MeV)</p> <p>E_{max} is the maximum photon energy in the simulation (300 GeV)</p> <p>N_{all} is the total number of events in the sample (before trigger)</p> <p>Peak effective area, A_{peak}, is defined as the maximum A_{eff} over all sliding window positions inside the energy range covered by the simulation. The energy at which the maximum A_{eff} is achieved is E_{peak}. The fraction of photon events passed by the filter at the optimal window position is ϵ_{peak}.</p> <p>The LAT field of view is determined from the 1/E photon sample whose incidence angle is isotropic in the upper hemisphere (2π steradians). The sliding energy window with the same width centered on E_{peak} is used to select the photon log-energy interval for which the field of view is determined. The field of view is calculated as $2\pi\epsilon/\epsilon_{peak}$ where ϵ is the fraction of events passed by the filter for the isotropic sample within the selected energy window.</p> <p>The peak spacecraft interface rate is determined as the maximum size of the data transferred over the VSC science interface each second in the testbed run with the background sample and default filter configuration.</p> <p>The spacecraft interface volume is determined as the average spacecraft interface rate in the background runs multiplied by 86,400 seconds.</p>	<p>Complete/ Not Complete</p>
5	<p>Confirm the outputs of the data analysis script were saved to the repository. Record the directory location of the output as indicated in Section 6.3.</p>	<p>Complete/ Not Complete</p>

Step No.	Description of Step	Step Outcome
6	<p>Review the outputs of the data analysis script on the test terminal. The test passes if every line of the output contains the word "PASS". Successful completion of this step fulfills all test objectives and sub-objectives. Example data analysis script output is shown below:</p> <p>Effective area at 20 MeV : ?? cm^2 : PASS Effective area at 100 MeV : ?? cm^2 : PASS Effective area at 300 GeV : ?? cm^2 : PASS Peak effective area : ?? cm^2 : PASS Field of view : ?? sr : PASS Peak SC interface rate : ?? Mbps : PASS SC interface volume with default configuration : ?? Gb : PASS SC interface volume with tightened event selection : ?? Gb : PASS SC interface volume with filter configured to reject all events : 0 Gb : PASS</p>	<p>Pass/ Fail</p>

Initial to confirm.

_____ Date _____ Time _____ Test Engineer _____ QAE

7.TEST POST-CONDITIONS AND OVERALL OUTCOME

7.1Test Post-Conditions

The following post-conditions are analyzed and verified by the test script:

No.	Post-Condition	Post-Condition Met? (Yes/No)
N/A	N/A	N/A

The Test Engineer and Quality Assurance Engineer verify that all test post-conditions are met.

_____ Date _____ Time _____ Test Engineer _____ QAE

7.2Overall Outcome of EVTFIL_002

Based on the analysis of the test results, the overall outcome of Test EVTFIL_002 is as follows:

- Passed** - all of the expected outcomes for the test were confirmed
- Failed** - one or more of the test outcomes were not confirmed

Date Test Engineer QAE

8.CERTIFICATION

I certify that the information obtained under this test procedure is as represented and the information recorded in this document is complete and correct. Any deviations from test procedures described herein are identified in Appendix A.

Date Test Engineer (Print Name) Test Engineer (Signature)

I certify that the information obtained through execution of this test procedure is as represented and the information recorded in this document is complete and correct. Execution of the test, storage of the results, and verification of outcomes were carried out in accordance with quality standards defined in the GLAST Quality Manual (LAT-MD-00091).

Date Software QA Engineer (Print Name) Software QA Engineer (Sign)

I certify that the information obtained under this test procedure is as represented and the information recorded in this document is complete and correct. The test procedure, as designed and executed, does indeed verify that the FSW functionality under test satisfies the corresponding requirements from the Flight Software Specification – Level III.

Date FSW Manager (Print Name) FSW Manager (Signature)

APPENDIX A: DEVIATIONS FROM THE QUALIFICATION TEST PROCEDURE

This section details any deviations from the hardware configuration, software configuration, or test procedure followed during the execution of the test or tests described in this Qualification Test Procedure document. All deviations from the approved procedure are agreed to by the Test Engineer and the Software Quality Engineer during the test execution session. All deviations must be reported during the Post Qualification Test Review, where their impact on the test results will be evaluated.

Hardware Deviations

Describe any deviations from the hardware configuration defined in Section 5.1. Name the hardware that was modified and describe the modifications. If hardware is *replaced* during execution of the test, name the replaced hardware, the manufacturer, and list an identification number (e.g., GLAT ID number).

Software Deviations

Describe any changes made to the software configuration under test or the software configuration used to support test execution, as defined in Section 5.2. Give version numbers of all FSW packages and test packages that were modified. Describe how the contents of the modified software load were verified. Describe these deviations for each test that was modified.

Procedural Deviations

Specify any deviations from the test procedure for the test being executed. If this document contains more than one test procedure, list the procedure by number (e.g., “MEMMGT_001”). List by number the steps modified or skipped. Provide a numbered sequence listing any added steps. Describe these deviations for each test that was modified.
