



DCN No.
LAT-XR-07131-01

LAT PROJECT DOCUMENT CHANGE NOTICE (DCN)

SHEET 1 OF 2

ORIGINATOR: Mike DeKlotz PHONE: 650-926-4752 DATE: 8/16/05

CHANGE TITLE: DCN for LAT Flight Software Test Procedures ORG.:

DOCUMENT NUMBER	TITLE	NEW REV.
LAT-TD-07126	LAT FSW Qualification Test Procedure: DCMODE_001: ACD Diagnostics & Calibration	01
LAT-TD-07127	LAT FSW Qualification Test Procedure: DCMODE_002: ACD Diagnostics & Calibration	01
LAT-TD-07128	LAT FSW Qualification Test Procedure: DCMODE_003: TKR Diagnostics & Calibration	01
LAT-TD-07129	LAT FSW Qualification Test Procedure: NBTLMV_001: Narrowband Telemetry Housekeeping & Low-rate Science Data Verificaiton	01
LAT-TD-07130	LAT FSW Qualification Test Procedure: NBTLMV_002: Diagnostic Telemetry Verification	01

CHANGE DESCRIPTION (FROM/TO):

LAT-TD-07132-01- LAT FSW Qualification Test Procedure: FSWINI_001: FSW Initialization-SIU Primary Boot
 LAT-TD-07133-01- LAT FSW Qualification Test Procedure: FSWINI_002: FSW & LAT Initialization- Boot Self-Test & Boot Housekeeping Telemetry
 LAT-TD-07134-01- LAT FSW Qualification Test Procedure: FSWINI_003: FSW & LAT Initialization- Multiple Boot Images
 LAT-TD-07135-01- LAT FSW Qualification Test Procedure: FSWINI_004: FSW & LAT Initialization- SIU Hardware Reboot in response to the Signal on the Discrete Lines
 LAT-TD-07136-01- LAT FSW Qualification Test Procedure: FSWINI_005: FSW Initialization- EPU Primary Boot
 LAT-TD-07137-01- LAT FSW Qualification Test Procedure: FSWINI_006: FSW & LAT initialization- Reset Source
 LAT-TD-07138-01- LAT FSW Qualification Test Procedure: FSWINI_007: FSW & LAT Initialization- Storage & Retrieval of System Errors During SIU Primary Boot
 LAT-TD-07139-01- LAT FSW Qualification Test Procedure: FSWINI_008: FSW & LAT Initialization- Storage & Retrieval of System Errors During EPU Primary Boot
 LAT-TD-07140-01- LAT FSW Qualification Test Procedure: FSWINI_009: FSW & LAT Initialization- SIU Boot Status on Discrete Lines & SISU Boot Housekeeping Telemetry
 LAT-TD-07141-01- LAT FSW Qualification Test Procedure: FSWINI_010: FSW & LAT Initialization- SIU & EPU Secondary Boot
 LAT-TD-07142-01- LAT FSW Qualification Test Procedure: FSWINI_011: FSW & LAT Initialization- SIU & EPU Secondary Boot Error Mitigation
 LAT-TD-07143-01- LAT FSW Qualification Test Procedure: FSWINI_012: FSW & LAT Initialization- LAT SEU Protection
 LAT-TD-07144-01- LAT FSW Qualification Test Procedure: FSWINI_013: FSW & LAT Initialization- LAT Memory Scrubbing
 LAT-TD-07145-01- LAT FSW Qualification Test Procedure: FSWINI_014: FSW & LAT Initialization- Watchdog Management During Boot
 LAT-TD-07146-01- LAT FSW Qualification Test Procedure: FSWINI_015: FSW & LAT Initialization- Soft Reset
 LAT-TD-07152-01 - LAT FSW Qualification Test Procedure:FECALB_001: Charge Injection Calibration – TOT Measurements
 LAT-TD-07153-01- LAT FSW Qualification Test Procedure:FECALB_002: Charge Injection Calibration – TKR Threshold and Charge Scans
 LAT-TD-07154-01- LAT FSW Qualification Test Procedure: FECALB_003: Charge Injection Calibration – TKR Trigger Check
 LAT-TD-07155-01- LAT FSW Qualification Test Procedure: FECALB_004: Charge Injection Calibration – ACD Charge Injection
 LAT-TD-07156-01- LAT FSW Qualification Test Procedure: FECALB_005: Charge Injection Calibration – CAL Charge Injection
 LAT-TD-07157-01- LAT FSW Qualification Test Procedure: WBTLMV_001: Wideband Telemetry Verification – Science Data Format and Volume

REASON FOR CHANGE:

ACTION TAKEN: Change(s) included in new release DCN attached to document(s), changes to be included in next revision
 Other (specify):

DISPOSITION OF HARDWARE (IDENTIFY SERIAL NUMBERS):

DCN DISTRIBUTION:

No hardware affected (record change only)

List S/Ns which comply already:

List S/Ns to be reworked or scrapped:

List S/Ns to be built with this change:

List S/Ns to be retested per this change:

SAFETY, COST, SCHEDULE, REQUIREMENTS IMPACT? YES NO

If yes, CCB approval is required. Enter change request number:

APPROVALS	DATE	OTHER APPROVALS (specify):	DATE
ORIGINATOR: M. DeKlotz (signature on file)	8/16/05		
ORG. MANAGER: D. Horn (signature on file)	8/16/05		
PSA- K. Burlingham (signature on file)	8/16/05		
DCN RELEASE: Natalie Cramar (signature on file)	8/16/05	Doc. Control Level: <input checked="" type="checkbox"/> Subsystem <input type="checkbox"/> LAT IPO <input type="checkbox"/> GLAST Project	

DCN No: LAT-XR-07131-01



DCN No.
LAT-XR-07131-01

LAT PROJECT DOCUMENT CHANGE NOTICE

SHEET 2 OF 2

Continuation:

LAT-TD-07158-01- LAT FSW Qualification Test Procedure: FILMGT_001: File Management Verification
LAT-TD-07159-01- LAT FSW Qualification Test Procedure: MEMMGT_002: Memory Load Data
LAT-TD-07160-01- LAT FSW Qualification Test Procedure: NBTLMV_003: ACD HSK Anomaly Response and Alert Telemetry Verification
LAT-TD-07161-01- LAT FSW Qualification Test Procedure: OPMODE_001: LAT Operational Mode Control
LAT-TD-07162-01- LAT FSW Qualification Test Procedure: THRMCS_001: LAT Thermal Control System
LAT-TD-07163-01- LAT FSW Qualification Test Procedure: VSGIFV_001: Discrete Signal Interfaces
LAT-TD-07164-01- LAT FSW Qualification Test Procedure: CMDFNC_003: 1553 Interface and Command Functional Verification
LAT-TD-07054-01- LAT FSW Qualification Test Procedure: EVTPMO_001: Event Performance Monitoring and Verification – Software-Related Deadtime
LAT-TD-07055-01- LAT FSW Qualification Test Procedure: EVTPMO_002: Event Performance Monitoring and Verification –Acquisition of VETO Rates from the GEM
LAT-TD-07056-01- LAT FSW Qualification Test Procedure: EVTPMO_003: Event Performance Monitoring and Verification – Level 1 Trigger Rates
LAT-TD-07057-01- LAT FSW Qualification Test Procedure: EVTPMO_004: Event Performance Monitoring and Verification – Monitor CNO Rates
LAT-TD-07112-01- LAT FSW Qualification Test Procedure: EVTFIL_001: Event Filtering – Interface from the Event Builder
LAT-TD-07113-01- LAT FSW Qualification Test Procedure: EVTFIL_002: Event Filtering – Event Filter Rates and Capacity
LAT-TD-07114-01- LAT FSW Qualification Test Procedure: EVTFIL_003: Event Filtering – Event Filter Reprogramming
LAT-TD-07115-01- LAT FSW Qualification Test Procedure: EVTFIL_004: Event Filtering – Event Filter Bypass

	Document # LAT-TD-07126-01	Date effective
	Author(s) Sergio Maldonado	Supersedes
	Subsystem/Office Electronics & DAQ Subsystem	
Document Title LAT FSW Qualification Test Procedure: DCMODE_001: ACD Diagnostics and Calibration		

CHANGE HISTORY LOG

Revision	Effective Date	Description of Changes
01	August 16, 2005	Original

TABLE OF CONTENTS

Table of Contents	3
1. Scope	3
1.1 Test Suite	3
1.2 Test ID	3
1.3 Requirement(s) Tested	3
2. DEFINITIONS AND ACRONYMS	3
2.1 Definitions	3
2.2 Acronyms	3
3. REFERENCES	3
3.1 Applicable Documents	3
4. REQUIREMENTS	3
4.1 Test Data, Equipment and Software	3
4.2 Quality Assurance	3
4.3 Safety	3
4.4 Warnings, Cautions, and Notes	3
4.5 General Instructions	3
5. SETUP	3
5.1 Hardware Setup	3
5.2 Software Setup	3
5.3 Setup Validation	3
6. TEST PROCEDURE FOR DCMODE_001	3
6.1 Test Objective	3
6.2 Test Input Files	3

6.3	Test Preparation	3
6.4	Test Procedure and Test Analysis.....	3
7.	TEST POST_CONDITIONS AND OVERALL OUTCOME.....	3
7.1	Test Post-Conditions.....	3
7.2	Overall Outcome of DCMODE_001	3
8.	CERTIFICATION	3
	Appendix A: Deviations from the Qualification Test Procedure.....	3

1. **SCOPE**

This document describes the procedure followed for qualification testing of the LAT FSW. This Qualification Test Procedure document describes one of the qualification tests executed to verify compliance with the requirements defined in the “Flight Software Specification – Level III” (LAT-SS-00399).

1.1 **Test Suite**

DCMODE

This suite of tests shall verify that the SIU FSW properly engages in diagnostic operations upon command, and then properly execute the requested diagnostic algorithms. The suite also confirms that FSW responds properly to valid diagnostics mode-related telecommands.

1.2 **Test ID**

DCMODE_001

DCMODE_001 verifies FSW support for ACD related diagnostic operations include cosmic ray calibration, ACD triggering, and pedestal data collection.

1.3 **Requirement(s) Tested**

The Qualification Test Procedure described herein is performed to verify that the FSW satisfies the following requirement(s), quoted from the Flight Software Specification – Level III:

Requirement Number	Requirement Name	Requirement	Level of Requirements Verification in This Test
5.3.13.1.1	ACD Cosmic Ray Sample Events	<p>[1] (3.1.3.2.3, 3.3.3.4)</p> <p>Upon receipt of the appropriate command, FSW shall process a sample of events that are identified as likely to be cosmic rays. Data transmitted would include PHA data for the events (not a spectrum accumulated on board).</p> <p>Note: This data will be used to monitor the MIP peak in the tiles.</p>	Full
5.3.13.2.1	ACD Trigger Mode	<p>FSW shall configure the ACD to ACD Trigger Mode, as defined in a configurable file, upon command. See [30] for details.</p>	Full
5.3.13.2.2	Pedestal Data	<p>[1] (3.1.3.2.3, 3.3.3.2, 3.3.3.4), [4] (5.4.6)</p> <p>Upon receipt of the appropriate command, FSW shall put the detector in 4-range, non-zero suppressed mode, and take at least 10K events for further processing on the ground.</p> <p>Note: Additional processing of the data on the ground will extract the pedestal information.</p>	Full

If the requirement(s) quoted above cite external documents (e.g., "...Further details are provided in [11]"), consult LAT-SS-00399 for the list of citations.

2. DEFINITIONS AND ACRONYMS

The following terms, abbreviations, and acronyms are used in this document:

2.1 Definitions

Hz	Hertz, unit of frequency
s, sec	Seconds
V	Volt
W	Watt

2.2 Acronyms

CAL	Calorimeter
EGSE	Electrical Ground Support Equipment
GASU	Global trigger Anti-collision Spacecraft Unit
PTR	Post Test Review
TEM	Tower Electronics Module
TKR	Tracker
TPS	Tower Power Supply
TRR	Test Readiness Review
QAE	Quality Assurance Engineer
TE	Test Engineer
1 PPS	One Pulse per Second

3. REFERENCES

The list below provides documents that are to be used as references for this procedure:

3.1 **Applicable Documents**

<u>Document Number</u>	<u>Description</u>
<u>SPECIFICATIONS</u>	
LAT-SS-00399	LAT Flight Software Level III Specification
1196 EI-S46310-000	GLAST 1553 Bus Protocol Interface Control
LAT-TD-02659	LAT Flight Software Telecommand and Telemetry Formats
LAT-TD-0561	The Virtual Spacecraft (VSC)
<u>PROCEDURES</u>	
N/A	
<u>PLANS</u>	
LAT-MD-00039	Performance Assurance Implementation Plan
LAT-MD-00078	GLAST LAT System Safety Program Plan
LAT-MD-00404	LAT Contamination Control Plan
LAT-MD-00408	LAT Program Instrument Performance Verification Plan
LAT-SS-00296	T & DF Test Plan
LAT-TD-00297	LAT Electronics Test Plan
LAT-TD-00786	LAT Flight Software Test Plan
LAT-MD-00104	LAT FSW Management Plan
<u>DRAWINGS</u>	
N/A	
<u>OTHER</u>	
LAT-MD-00091	GLAST Quality Manual
LAT-MD-00471	Control of Nonconforming Product
LAT-MD-00472	Corrective and Preventative Action

4. REQUIREMENTS

This section lists the requirements that shall be followed during the LAT FSW Qualification Testing process.

The Performance Assurance Implementation Plan, LAT-MD-00039, shall be utilized to ensure that the products produced by the GLAST LAT project intended for design qualification, flight and critical ground support equipment usage meet the required levels of quality and functionality for their intended purposes.

The LAT Program Instrument Performance Verification Plan, LAT-MD-00408, shall be utilized to address the testing to be performed at the unit/subsystem and instrument level for flight qualification, proto-flight and acceptance testing phases. Also included are the necessary processes/procedures and systems assurance activities.

4.1 Test Data, Equipment and Software

This procedure shall follow the requirements found in the Control of Nonconforming Product, LAT-MD-00471. This document establishes the method to identify and control nonconforming product developed by the LAT project team.

4.2 Quality Assurance

This procedure shall follow the requirements found in the Corrective and Preventative Action document, LAT-MD-00472 and the GLAST Quality Manual, LAT-MD-00091.

The Corrective and Preventative Action document establishes the method to be used to initiate, implement, evaluate and record corrective and preventive actions. The GLAST Quality Manual defines the methods implemented by the GLAST LAT project to ensure consistent quality of all processes for procurement, design, development and production of flight hardware, flight software and all associated ground support equipment interfacing with flight hardware and software.

4.3 Safety

This procedure shall follow the requirements found in the GLAST LAT System Safety Program Plan, LAT-MD-00078. This document defines all phases of the LAT program including: design, development, fabrication, handling, transportation, storage, test, assembly and operation.

WARNING: When high voltages are present extreme care should be exercised.

4.4 Warnings, Cautions, and Notes

The following SAFETY ALERTS are intended to create awareness of the potential safety hazards and the steps that must be taken to avoid accidents. These same alerts are used throughout this document to identify specific hazards that may endanger personnel and/or equipment.

Identification of every conceivable hazardous situation is impossible. Therefore, all personnel have the responsibility to diligently exercise safe practices whenever exposed to this equipment.

WARNING: Indicates a potential hazardous situation which, if not avoided, could result in death or injury.

CAUTION: Indicates a potential hazardous situation which, if not avoided, could result in damage to equipment.

Note: Indicates a notification of information that is important, but not hazard related.

4.5 General Instructions

This qualification test procedure shall be conducted on a formal basis to its latest approved and released version. The designated Software QAE shall be notified 24 hours prior to the start of this procedure. Software QAE may monitor the execution of all or part of this procedure should they elect to do so.

The Test Engineer conducting this test shall read this document in its entirety and resolve any apparent ambiguities before beginning the procedures described herein.

Deviations from the procedures described in this document and breaks in hardware or software configuration can only be initiated by the Test Engineer, must be approved by QA, and must be documented in Appendix A.

Any nonconformance/defect/anomaly is to be reported in JIRA. Refer to the LAT Flight Software Test Plan LAT-TD-00786 for guidance. Do not alter or break configuration if a failure occurs. Notify Software Quality Assurance.

All success conditions for a test must be met for the test to pass.

5. SETUP

This section describes the hardware and software configuration used for the qualification test described later in this document. Any break from configuration or deviation from a particular procedure must be authorized by the Quality Assurance Engineer and documented in Appendix A.

5.1 Hardware Setup

The list below indicates the equipment that is used to execute the tests described in this document.

Hardware Unit	Manufacturer	GLAT Number (and Hardware Sub-Units by GLAT Number)	Firmware Version (where applicable)
Virtual Spacecraft (VSC)	SLAC		
Spacecraft Interface Unit (SIU)	SLAC		
Event Processing Unit (EPU): 2 (EPU0 and EPU1)	SLAC		
Global Trigger AEM Signal Distribution Unit (GASU)	SLAC		
Front End Simulator (FES)	SLAC		
Power Distribution Unit (PDU)	SLAC		
1553 cables and couplers	SLAC		
Unix or Linux Host Establishes connection between VSC and the terminal from which the test is run.			
Power supply for SIU	SLAC		

The Figure below depicts the Testbed on which this qualification test is performed. The particular hardware units utilized in this test are itemized by GLAT number and firmware version in the

preceding table.

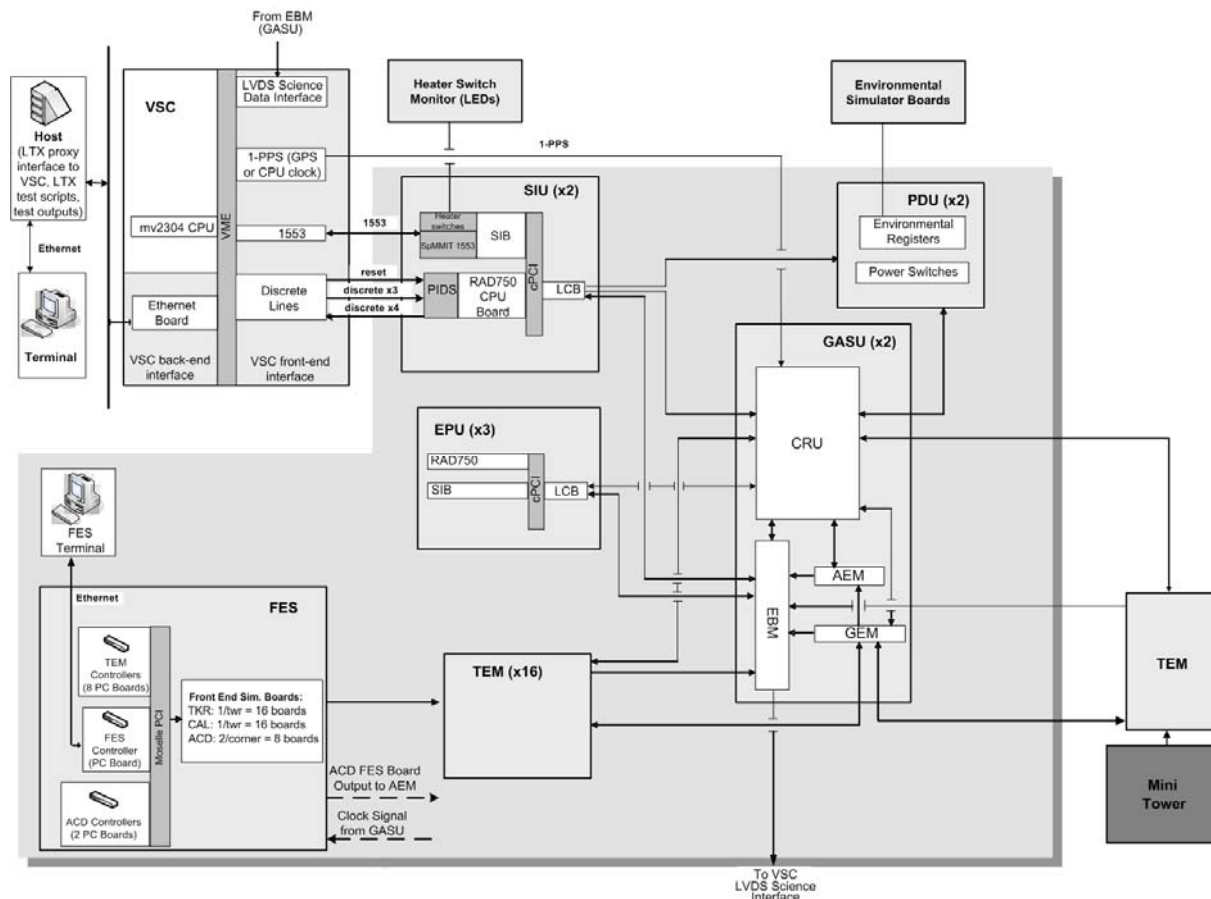

Figure 1. FSW Testbed

5.2 Software Setup

The software required to prepare for and execute the tests described in this Qualification Test Procedure document is itemized in this section.

5.2.1 Test Tools

The following table specifies the test executive used to run this qualification test, and identifies the other software tools used to support the execution of the test. The “Software Version Number” column identifies the version number of the test tool being used; alternatively, this column identifies the hardcopy attachment to this document that records the version of the tool being used (e.g., “Attachment 1”). The “Path to Attachment” column identifies the directory in which the electronic copy of any hardcopy attachment is saved (if applicable).

Software	Description of Software	Software Version Number (or Specify Attachment Number)	Path to Attachment (If Applicable)
LTX	LAT Test Executive		
VSC	Virtual Spacecraft system software		
VPI	VSC Python/Proxy Interface		

5.2.2 Test Scripts

The following table identifies the test scripts that are run to execute this qualification test. The “Script Version Number” column identifies which version of the script is being used; alternatively, this column identifies the hardcopy attachment to this document that records the version of the script being used (e.g., “Attachment 1”). The “Path to Attachment” column identifies the directory in which the electronic copy of any hardcopy attachment is saved (if applicable).

Test Script	Description of Test Script	Script Version Number (or Specify Attachment Number)	Path to Attachment (If Applicable)
DCMODE_001.py	This script, the main test execution script, tests FSW operating in Application Mode. It executes tests of SIU FSW, EPU0 FSW, and EPU1 FSW. The script controls the entire test process, detecting the state of the hardware and FSW and advancing SIU and EPU FSW through the different necessary operational modes required to execute the test.		
DCMODE_001_analyze.py	Post-processing result analysis script.		

5.2.3 Flight Software

This qualification test is performed on a complete, integrated Candidate Release of FSW. All FSW libraries under test are final Flight Unit Candidate versions. The test described in this document is designed to evaluate the particular FSW packages and constituents listed in the following table; for clarity, only those packages and constituents that are the focus of the test are listed below.

FSW Package	Constituent(s)
EFC	efc_XXX

FSW Package	Constituent(s)

The Candidate Release into which these FSW constituents are integrated is identified in the following table. The “Candidate Release Build Number” column specifies the build number of the FSW Candidate Release under test (e.g., “B0-0-1”). The “Candidate Release Attachment Number” column identifies which hardcopy attachment to this document confirms the name and version number of the full set of FSW packages and constituents used in the test (e.g., “Attachment 2”). The “Path to Attachment” column specifies where in the test repository an electronic copy of the hardcopy attachment has been saved.

Candidate Release Build Number	Candidate Release Attachment Number	Path to Attachment

5.3 Setup Validation

5.3.1 Hardware Validation

The following signatures confirm that the Test Engineer and Quality Assurance Engineer have verified the GLAT numbers, firmware version numbers, and the proper connection of all hardware listed in the table in Section 5.1.

 Date Time Test Engineer QAE

5.3.2 Software Validation

The Test Engineer performs the following procedure to validate the software setup for this qualification test and records completion of the setup validation steps in the space provided.

Step No.	Description of Step	Step Outcome
1	Record the version numbers of all test tools used to perform this qualification test in the table in Section 5.2.1	Complete/ Not Complete

Step No.	Description of Step	Step Outcome
2	Record the version numbers of all test scripts used to perform this qualification test in the table in Section 5.2.2	Complete/ Not Complete
3	Record the version numbers of the FSW constituents and the Candidate Release on which this test is performed in Section 5.2.3.	Complete/ Not Complete

The following signatures confirm that, using the procedure described in the previous table, the Test Engineer and Quality Assurance Engineer have verified that all versions of test support software, test scripts, and FSW constituents match those identified in Section 5.2.

 Date Time Test Engineer QAE

6. TEST PROCEDURE FOR DCMODE 001

6.1 Test Objective

Testing of the ACD diagnostic data for purposes of calibration involves four primary steps:

1. Load the FES with the appropriate file representing a cosmic ray background.
2. Configure the trigger and ACD, using the LAT configuration software, to accept cosmic rays, and/or enter ACD Trigger Mode.
3. Configure the filter software to select candidate CR events while preserving downlink bandwidth. This involves the adjustment of trigger prescale parameters.
4. Initiate physics run, via telecommand, to acquire and telemeter resulting event data.

Number	Test Sub-Objective
1	Verify FSW acceptance of ACD cosmic ray data and inclusion of PHA data in event output.
2	Verify successful configuration by file of the ACD to ACD trigger mode.
3	Verify successful configuration of the instrument to 4-range non-zero suppressed and a minimum of 10K pedestal events taken.

Analysis of results is performed as and when data arrives in telemetry. Typically analysis includes verifying the telemetry values against expected values and tagging the sub-objectives as either “PASS” or “FAIL”.

6.2 Test Input Files

The following table identifies all auxiliary files (e.g., Front End Simulator data files, GLEAM data files) used as inputs to this qualification test. Note that not all qualification tests use input data of this type. The “Input File Version Number” column identifies the version number of the auxiliary file being used; alternatively, this column identifies the hardcopy attachment to this document that records the version of the file being used (e.g., “Attachment 1”). The “Path to Attachment” column specifies where in the test repository an electronic copy of the hardcopy attachment has been saved.

Input File	Description of Input File	Input File Version Number (or Specify Attachment Number)	Path to Attachment (If Applicable)
TBD0.f	FES input file simulating cosmic ray background.		
TBD1.f	Event filter configuration file with ACD CR settings and output rate adjustment		
TBD2.f	LATC configuration file for ACD trigger mode		
TBD3.f	LATC configuration file with pedestal data settings		

6.3 Test Output Files

The following table identifies all files used as outputs to this qualification test. Note that not all qualification tests use output data of this type. The “Output File Version Number” column identifies the version number of the auxiliary file being used; alternatively, this column identifies the hardcopy attachment to this document that records the version of the file being used (e.g., “Attachment 1”). The “Path to Attachment” column specifies where in the test repository an electronic copy of the hardcopy attachment has been saved.

Output File	Description of Output File	Output File Version Number (or Specify Attachment Number)	Path to Attachment (If Applicable)
TBD4.ldf	Event data output file, LDF format, generated by VSC proxy interface (VPI)		

6.4 Test Preparation

After the hardware and software setup has been validated, steps may be required to place the hardware and FSW in an operational mode in which the qualification test can be performed or otherwise complete preparations for the test to begin.

The Test Engineer carries out the following procedure to prepare for qualification testing and records completion of the test preparation steps in the space provided.

Step No.	Description of Step	Step Outcome
1	Confirm that the VSC is powered up.	Complete/ Not Complete
2	Confirm that the SIU and the GASU are powered up: The voltage indicator on the SIU/GASU Xantrex power supply should display $28 \pm 0.2V$. The SIU feed "POWER ON" switch on the regulated feeds bus protection unit (BPU) should be flipped "ON". The SIU voltage indicator on the BPU should display $28 \pm 0.2V$. The SIU current as shown by the BPU indicator should be above 0.4A. The DAQ feed "POWER ON" switch on the BPU should be flipped "ON". The DAQ voltage indicator on the BPU should display $28 \pm 0.2V$.	Complete/ Not Complete

6.5 Test Procedure

This section describes the step by step procedure performed once the test preparation is complete. The Test Engineer proceeds with the qualification test procedure itself, as described below, and records the outcome of each step during test execution. The outcome of each step is either "Complete" or "Not Complete" (for steps which involve no analysis or verification).

Step No.	Description of Step	Step Outcome
1	At the test terminal, run the script <i>DCMODE_001</i> under LTX through the VSC with the following command: \$ ltx run DCMODE_001	Complete/ Not Complete

Step No.	Description of Step	Step Outcome
2	<p>The test script determines whether the SIU is powered on by checking whether SIU boot housekeeping telemetry is being transmitted. Regardless of the SIU's current operational mode, the script sends the SIU the LPBCRESET telecommand to reboot the unit.</p> <p>The script then checks whether the SIU FSW is operating in Boot Mode by detecting if boot housekeeping is being transmitted. If not, the script sends the LPBCRESET command and checks again.</p> <p>If the SIU FSW cannot be placed in Boot Mode, LTX prints an error message to the screen and exits, aborting the test.</p> <p>If the test is NOT aborted, mark "Complete" for the Step Outcome.</p>	Complete/ Not Complete
3	The script initializes the VSC software and starts proxy interface.	N/A
4	With FSW on the SIU in Boot Mode, send PBCRTOSEXEC telecommand to advance to secondary boot.	N/A
5	After completion of secondary boot, FSW modules are loaded and the SIU is placed in TERMINAL mode. Housekeeping telemetry LHKxxx shows LIM reporting terminal mode.	N/A
6	<p>Send telecommand LIMMAINFEEDON to initialize the LCB, PDU, and GASU. Housekeeping telemetry LHKxxx reports LIM in QUIESCIENT mode.</p> <p>Send telecommand LIMPOWERON with parameters set to enable power to all instrument subsystems.</p>	N/A
7	Initialize and start the FES run using input file TBD0.f for cosmic ray background simulation.	Complete/ Not Complete
8	Send telecommand LPAxxxx start physics run with filter configuration file TBD1.f to collect data for 3-5 minutes	N/A
9	<p>LAT flight software is in PHYSICS mode as reported by telemetry apid 0x30f mnemonic LIMTOPMODE</p> <p>Terminal displays LAT MODE: PHYSICS</p>	Complete/ Not Complete
10	Send telecommand LPAxxx to end physics run	N/A
11	Send telecommand LATCxxx with configuration file TBD2.f to enable ACD trigger.	N/A
12	Send telecommand LATCxxx to readback configuration containing enabled ACD trigger	N/A
13	Send telecommand LATCxxx with configuration file TBD5.f to enable pedestal settings.	N/A
14	Send telecommand LATCxxx to readback configuration containing enabled pedestal settings	N/A
15	Send telecommand LPAxxxx start diagnostic run to collect data for 15-30 minutes. The rate from input file * run time >= 10K events.	N/A
16	<p>LAT flight software is in DIAGNOSTIC mode as reported by telemetry apid 0x30f mnemonic LIMTOPMODE</p> <p>Terminal displays LAT MODE: DIAGNOSTIC</p>	Complete/ Not Complete
17	Send telecommand LPAxxx to end physics run	N/A

Initial to confirm.

Date

Time

Test Engineer

QAE

6.6 Test Analysis

The analysis for each of the sub-objectives is conducted by the main analysis script DCMODE_XXX. “Pass” or “Fail” is specified for steps involved in verifying completion of test objectives and sub-objectives.

Step No.	Description of Step	Step Outcome
1	At the conclusion of the test run, the analysis script <i>DCMODE_001_analyze.py</i> is autonomously executed: Review the terminal output of the analysis script for: Analyzing test output	Complete/ Not Complete
2	Event data archive file TBD4.ldf is loaded and parsed for event records with apid 0xxxx corresponding to ACD PHA values. Presence of such data verifies FSW receipt and processing of cosmic ray events, thereby verifying sub-objective 1. Review the terminal output of the analysis script for: ACD cosmic ray event PHA data validated: 0: PASS	Pass/ Fail
3	Event data archive file TBD4.ldf is parsed for data records with apid 0xxxx corresponding to LATC readback data. The readback data is compared to source input file TBD2.f to verify configuration of ACD in trigger mode, thereby verifying sub-objective 2. Review the terminal output of the analysis script for: ACD trigger mode configuration validated: 0: PASS	Pass/ Fail
4	Event data archive file TBD4.ldf is parsed for data records with apid 0xxxx corresponding to LATC readback data. The readback data is compared to source input file TBD3.f to verify configuration of instrument with pedestal settings, thereby partially verifying sub-objective 3.	Pass/ Fail
5	Review the terminal output of the analysis script for: Pedestal configuration verified: 0: PASS	Pass/ Fail
6	Event data archive file TBD4.ldf is parsed for 10k event records with apid 0xxxx corresponding to pedestal data, thus completing verification of sub-objective 3. Review the terminal output of the analysis script for: 10K pedestal event data verified: 0: PASS	Pass/ Fail

7. TEST POST CONDITIONS AND OVERALL OUTCOME

7.1 Test Post-Conditions

The following post-conditions are analyzed and verified by the test script as described in “Test Procedure and Test Analysis”:

No.	Post-Condition	Post-Condition Met? (Yes/No)
1	LAT flight software is in QUIESCIENT mode as reported by telemetry apid 0x30f mnemonic LIMTOPMODE Terminal displays LAT MODE: QUIESCIENT	

The Test Engineer and Quality Assurance Engineer verify that all test post-conditions are met.

 Date Time Test Engineer QAE

7.2 Overall Outcome of DCMODE_001

Based on the analysis of the test results, the overall outcome of Test DCMODE_001 is as follows:

- Passed** - all of the expected outcomes for the test were confirmed
- Failed** - one or more of the test outcomes were not confirmed

 Date Test Engineer QAE

8. CERTIFICATION

I certify that the information obtained under this test procedure is as represented and the information recorded in this document is complete and correct. Any deviations from test procedures described herein are identified in Appendix A.

Date Test Engineer (Print Name) Test Engineer (Signature)

I certify that the information obtained through execution of this test procedure is as represented and the information recorded in this document is complete and correct. Execution of the test, storage of the results, and verification of outcomes were carried out in accordance with quality standards defined in the GLAST Quality Manual (LAT-MD-00091).

Date Software QA Engineer (Print Name) Software QA Engineer (Sign)

I certify that the information obtained under this test procedure is as represented and the information recorded in this document is complete and correct. The test procedure, as designed and executed, does indeed verify that the FSW functionality under test satisfies the corresponding requirements from the Flight Software Specification – Level III.

Date FSW Manager (Print Name) FSW Manager (Signature)

APPENDIX A: DEVIATIONS FROM THE QUALIFICATION TEST PROCEDURE

This section details any deviations from the hardware configuration, software configuration, or test procedure followed during the execution of the test or tests described in this Qualification Test Procedure document. All deviations from the approved procedure are agreed to by the Test Engineer and the Software Quality Engineer during the test execution session. All deviations must be reported during the Post Qualification Test Review, where their impact on the test results will be evaluated.

Hardware Deviations

Describe any deviations from the hardware configuration defined in Section 5.1. Name the hardware that was modified and describe the modifications. If hardware is *replaced* during execution of the test, name the replaced hardware, the manufacturer, and list an identification number (e.g., GLAT ID number).

Software Deviations

Describe any changes made to the software configuration under test or the software configuration used to support test execution, as defined in Section 5.2. Give version numbers of all FSW packages and test packages that were modified. Describe how the contents of the modified software load were verified. Describe these deviations for each test that was modified.

Procedural Deviations

Specify any deviations from the test procedure for the test being executed. If this document contains more than one test procedure, list the procedure by number (e.g., “DCMODE_001”). List by number the steps modified or skipped. Provide a numbered sequence listing any added steps. Describe these deviations for each test that was modified.
