



DCN No.
LAT-XR-07131-01

LAT PROJECT DOCUMENT CHANGE NOTICE (DCN)

SHEET 1 OF 2

ORIGINATOR: Mike DeKlotz **PHONE:** 650-926-4752 **DATE:** 8/16/05

CHANGE TITLE: DCN for LAT Flight Software Test Procedures **ORG.:**

DOCUMENT NUMBER	TITLE	NEW REV.
LAT-TD-07126	LAT FSW Qualification Test Procedure: DCMODE_001: ACD Diagnostics & Calibration	01
LAT-TD-07127	LAT FSW Qualification Test Procedure: DCMODE_002: ACD Diagnostics & Calibration	01
LAT-TD-07128	LAT FSW Qualification Test Procedure: DCMODE_003: TKR Diagnostics & Calibration	01
LAT-TD-07129	LAT FSW Qualification Test Procedure: NBTLMV_001: Narrowband Telemetry Housekeeping & Low-rate Science Data Verificaiton	01
LAT-TD-07130	LAT FSW Qualification Test Procedure: NBTLMV_002: Diagnostic Telemetry Verification	01

CHANGE DESCRIPTION (FROM/TO):

LAT-TD-07132-01- LAT FSW Qualification Test Procedure: FSWINI_001: FSW Initialization-SIU Primary Boot
 LAT-TD-07133-01- LAT FSW Qualification Test Procedure: FSWINI_002: FSW & LAT Initialization- Boot Self-Test & Boot Housekeeping Telemetry
 LAT-TD-07134-01- LAT FSW Qualification Test Procedure: FSWINI_003: FSW & LAT Initialization- Multiple Boot Images
 LAT-TD-07135-01- LAT FSW Qualification Test Procedure: FSWINI_004: FSW & LAT Initialization- SIU Hardware Reboot in response to the Signal on the Discrete Lines
 LAT-TD-07136-01- LAT FSW Qualification Test Procedure: FSWINI_005: FSW Initialization- EPU Primary Boot
 LAT-TD-07137-01- LAT FSW Qualification Test Procedure: FSWINI_006: FSW & LAT initialization- Reset Source
 LAT-TD-07138-01- LAT FSW Qualification Test Procedure: FSWINI_007: FSW & LAT Initialization- Storage & Retrieval of System Errors During SIU Primary Boot
 LAT-TD-07139-01- LAT FSW Qualification Test Procedure: FSWINI_008: FSW & LAT Initialization- Storage & Retrieval of System Errors During EPU Primary Boot
 LAT-TD-07140-01- LAT FSW Qualification Test Procedure: FSWINI_009: FSW & LAT Initialization- SIU Boot Status on Discrete Lines & SISU Boot Housekeeping Telemetry
 LAT-TD-07141-01- LAT FSW Qualification Test Procedure: FSWINI_010: FSW & LAT Initialization- SIU & EPU Secondary Boot
 LAT-TD-07142-01- LAT FSW Qualification Test Procedure: FSWINI_011: FSW & LAT Initialization- SIU & EPU Secondary Boot Error Mitigation
 LAT-TD-07143-01- LAT FSW Qualification Test Procedure: FSWINI_012: FSW & LAT Initialization- LAT SEU Protection
 LAT-TD-07144-01- LAT FSW Qualification Test Procedure: FSWINI_013: FSW & LAT Initialization- LAT Memory Scrubbing
 LAT-TD-07145-01- LAT FSW Qualification Test Procedure: FSWINI_014: FSW & LAT Initialization- Watchdog Management During Boot
 LAT-TD-07146-01- LAT FSW Qualification Test Procedure: FSWINI_015: FSW & LAT Initialization- Soft Reset
 LAT-TD-07152-01 - LAT FSW Qualification Test Procedure:FECALB_001: Charge Injection Calibration – TOT Measurements
 LAT-TD-07153-01- LAT FSW Qualification Test Procedure:FECALB_002: Charge Injection Calibration – TKR Threshold and Charge Scans
 LAT-TD-07154-01- LAT FSW Qualification Test Procedure: FECALB_003: Charge Injection Calibration – TKR Trigger Check
 LAT-TD-07155-01- LAT FSW Qualification Test Procedure: FECALB_004: Charge Injection Calibration – ACD Charge Injection
 LAT-TD-07156-01- LAT FSW Qualification Test Procedure: FECALB_005: Charge Injection Calibration – CAL Charge Injection
 LAT-TD-07157-01- LAT FSW Qualification Test Procedure: WBTLMV_001: Wideband Telemetry Verification – Science Data Format and Volume

REASON FOR CHANGE:

ACTION TAKEN: Change(s) included in new release DCN attached to document(s), changes to be included in next revision
 Other (specify):

DISPOSITION OF HARDWARE (IDENTIFY SERIAL NUMBERS):

DCN DISTRIBUTION:

- No hardware affected (record change only)
- List S/Ns which comply already:
- List S/Ns to be reworked or scrapped:
- List S/Ns to be built with this change:
- List S/Ns to be retested per this change:
-

SAFETY, COST, SCHEDULE, REQUIREMENTS IMPACT? YES NO

If yes, CCB approval is required. Enter change request number:

APPROVALS	DATE	OTHER APPROVALS (specify):	DATE
ORIGINATOR: M. DeKlotz (signature on file)	8/16/05		
ORG. MANAGER: D. Horn (signature on file)	8/16/05		
PSA- K. Burlingham (signature on file)	8/16/05		
DCC RELEASE: Natalie Cramar (signature on file)	8/16/05	Doc. Control Level: <input checked="" type="checkbox"/> Subsystem <input type="checkbox"/> LAT IPO <input type="checkbox"/> GLAST Project	

DCN No: LAT-XR-07131-01



DCN No.
LAT-XR-07131-01

LAT PROJECT DOCUMENT CHANGE NOTICE

SHEET 2 OF 2

Continuation:

LAT-TD-07158-01- LAT FSW Qualification Test Procedure: FILMGT_001: File Management Verification
LAT-TD-07159-01- LAT FSW Qualification Test Procedure: MEMMGT_002: Memory Load Data
LAT-TD-07160-01- LAT FSW Qualification Test Procedure: NBTLMV_003: ACD HSK Anomaly Response and Alert Telemetry Verification
LAT-TD-07161-01- LAT FSW Qualification Test Procedure: OPMODE_001: LAT Operational Mode Control
LAT-TD-07162-01- LAT FSW Qualification Test Procedure: THRMCS_001: LAT Thermal Control System
LAT-TD-07163-01- LAT FSW Qualification Test Procedure: VSGIFV_001: Discrete Signal Interfaces
LAT-TD-07164-01- LAT FSW Qualification Test Procedure: CMDFNC_003: 1553 Interface and Command Functional Verification
LAT-TD-07054-01- LAT FSW Qualification Test Procedure: EVTPMO_001: Event Performance Monitoring and Verification – Software-Related Deadtime
LAT-TD-07055-01- LAT FSW Qualification Test Procedure: EVTPMO_002: Event Performance Monitoring and Verification –Acquisition of VETO Rates from the GEM
LAT-TD-07056-01- LAT FSW Qualification Test Procedure: EVTPMO_003: Event Performance Monitoring and Verification – Level 1 Trigger Rates
LAT-TD-07057-01- LAT FSW Qualification Test Procedure: EVTPMO_004: Event Performance Monitoring and Verification – Monitor CNO Rates
LAT-TD-07112-01- LAT FSW Qualification Test Procedure: EVTFIL_001: Event Filtering – Interface from the Event Builder
LAT-TD-07113-01- LAT FSW Qualification Test Procedure: EVTFIL_002: Event Filtering – Event Filter Rates and Capacity
LAT-TD-07114-01- LAT FSW Qualification Test Procedure: EVTFIL_003: Event Filtering – Event Filter Reprogramming
LAT-TD-07115-01- LAT FSW Qualification Test Procedure: EVTFIL_004: Event Filtering – Event Filter Bypass

	Document # LAT-TD-07164-01	Date effective 8/16/05
	Author(s) Shantha Condamoor Mark Arndt	Supersedes
	Subsystem/Office Electronics & DAQ Subsystem	
Document Title LAT FSW Qualification Test Procedure: C MDFNC_003: 1553 Interface and Command Functional Verification		

CHANGE HISTORY LOG

Revision	Effective Date	Description of Changes
01	8/16/05	Original

TABLE OF CONTENTS

Table of Contents	3
1. Scope	5
1.1 Test Suite	5
1.2 Test ID	10
1.3 Requirement(s) Tested	10
2. DEFINITIONS AND ACRONYMS	13
2.1 Definitions	13
2.2 Acronyms	13
3. REFERENCES	14
3.1 Applicable Documents	14
4. REQUIREMENTS	15
4.1 Test Data, Equipment and Software	15
4.2 Quality Assurance	15
4.3 Safety	15
4.4 Warnings, Cautions, and Notes	16
4.5 General Instructions	16
5. SETUP	17
5.1 Hardware Setup	17
5.2 Software Setup	18
5.3 Setup Validation	20
6. TEST PROCEDURE FOR CMDFNC_003	21
6.1 Test Objective	21
6.2 Test Input Files	22

6.3	Test Output Files.....	23
6.4	Test Preparation	23
6.5	Test Procedure and Test Analysis.....	24
7.	TEST POST_CONDITIONS AND OVERALL OUTCOME.....	30
7.1	Test Post-Conditions.....	30
7.2	Overall Outcome of CMDFNC_003.....	30
8.	CERTIFICATION	31
	Appendix A: Deviations from the Qualification Test Procedure.....	32

1. **SCOPE**

This document describes the procedure followed for qualification testing of the LAT FSW. This Qualification Test Procedure document describes one of the qualification tests executed to verify compliance with the requirements defined in the “Flight Software Specification – Level III” (LAT-SS-00399).

1.1 **Test Suite**

CMDFNC

The Test Suite is a logical grouping of a set of tests based on common functionalities and can be executed as a suite of tests in some order when the pre-conditions and post-conditions for each test within the suite have been met successfully.

This test procedure *CMDFNC_003* belongs in the Test Suite *CMDFNC* under the *FST* Project.

The *CMDFNC* tests verify that all LAT commands are executed through the 1553 interface with command execution and completion status reported in telemetry when command verification features are switched on. These tests also verify that the SIU FSW validates commands and command parameters prior to command execution.

1.1.1 **Relationship of CMDFNC_003 to Other Test Suites**

The *CMDFNC_003* test, combined with tests from other FSW qualification test suites, verifies that FSW is capable of exchanging commands, low-rate telemetry, time messages and ancillary data messages over the 1553 Bus. These tests also verify that such data has proper data integrity, and that commands are validated prior to execution.

The *CMDFNC_003* test verifies proper handling of a subset of LAT commands and telemetry (defined below), and also verifies that FSW properly handles *all* FSW telecommands when those commands are *invalid* (i.e., the commands have incomplete data or invalid parameters). The following table summarizes how various aspects of 1553 interface and command functional testing are distributed among the qualification test suites.

Test Suite	Commands and Telemetry Tested
CMDFNC	<p>See Command and Telemetry Formats Handbook, for the complete set of commands and telemetry defined by FSW.</p> <p>Handling of the following LAT FSW commands when such commands are valid. Data Integrity and Command Parameter Verification of FSW's acceptance and processing of valid commands are performed for the following commands based on the Command Verification Telemetry that is sent in response to each of the commands and/or by the analysis of telemetry that is received in response to these commands:</p> <p>LCI Commands: CALIBRATE, ABORT</p> <p>LCM Commands LCMSCRUBRUN, LCMSCRUBCFG, LCMERRORCFG, msgResponse, cmdResponse, LCMMODDUMP, LCMTASKDUMP, LCMPCIERRC, LCMMEMERRC</p> <p>LIM Commands: LIMARRABORT, LIMARRRESPONSE, LIMSAFEMODE, LIMHOLDENTER, LIMHOLDEXIT, LIMLOADSHED, LIMMAINFEEDON, LIMPOWEROFF, LIMPOWERON, LIMSAEAENTER, LIMSAEAEXIT, LIMTOOABORT, LIMTOOSTART</p> <p>LSM Commands: LSMSIATTITUDE, LSMSIANCILLARY, LSMSITIMETONE.</p> <p>LTC Commands: LTCRESTART, LTCSTART, LTCSTOP,, LTCSETMODE, LTCHTRONOFFCNTL, LLTCSETPARAM, LTCSETTLMFREQ</p> <p>Handling of all LAT FSW commands when such commands <i>invalid</i>. Invalid commands include incomplete data packets or invalid command parameters or invalid header and checksum values. Verification of FSW's rejection of invalid commands are performed for all commands based on the Command Verification Telemetry that is sent in response to each of the commands.</p> <hr/> <p>Handling of the following LAT FSW telemetry for CCSDS conformance and Diagnostics Telemetry Verification:</p> <p>CTDB Telemetry: LCTBRTDIAG</p> <p>ITC Telemetry: CmdConfirm</p> <p>LCI Telemetry: TERMINATE</p> <p>LCM Telemetry: LCMMODLIST, LCMTASKLIST, LCMPCIERR, LCMMEMERR</p> <p>LIM Telemetry: State</p>
FILMGMT	<p>FILE Commands: LFILUPLSTART, LFILUPLCANCEL, LFILUPLCOMMIT, LFILUPLDATA, LFILUPLEPU,</p> <p>LFS Commands: LLFSFILEDELETE, LLFSFILECOPY, LLFSDIRCREATE, LLFSDIRDELETE, LLFSFILEDUMPC, LLFSDIRDUMP, LLFSSYSSTATUS</p> <hr/> <p>LFS Telemetry: LLFSDIRLIST, LLFSROOTLIST, LLFSSYSLIST, LLFSDUMPCTDB</p>
MEMMGT	<p>MEM Commands: LMEMDUMPMEM, LMEMDUMPCANCEL, LMEMDUMPPCI, LMEMDUMPPREG, LMEMLOADMEM, LMEMLOADPCI, LMEMLOADREG, LMEMDUMPPPOOL, LMEMDUMPSYMVAL, LMEMDUMPSYMREL</p> <p>PBC Commands: LPBCSTART, LPBCRESET, LPBCERRDUMP, LPBCRTOSEXEC</p>

Test Suite	Commands and Telemetry Tested
	MEM Telemetry: LMEMPOOLDATA, LMEMSYMVAL, LMEMSIUDATA, LMEMEPU0DATA, LMEMEPU1DATA PBC Telemetry: LBTHKP, LBTEPU0HKP, LBTEPU1HKP
NBTLMV	LHK Commands: LHKREQDIAGPKT, LHKSYSRESET, LHKSTOPDIAG LMC Commands: LMCCALLRS, LMCTKRLRS, LMCACDTILEPAIR, LMCACDTILEALL, LMCSTOPCOUNT, LMCTEMDEADTIME LTC Commands: LLTCSETTLMFREQ LHK Telemetry: TemEnvPwr0 through TemEnvPwr5 (6 packets total), TemEnvTemp0 through TemEnvTemp7 (8 packets total), PduEnv0 through PduEnv 7 (8 packets total), AemEnv0, Lrs0, CmdCnt0, CmdCnt1, FileStats, CpuMetr, MemStats0, MemStats1, LtcData (4 packets), DiagTemEnvPwr0 through DiagTemEnvPwr 5 (6 packets total), DiagTemEnvTemp0 through DiagTemEnvTemp 7 (8 packets total), DiagPduEnv0 through DiagPduEnv7 (8 packets total), DiagAemEnv0, DiagLrs0, DiagCmdCnt (2 packets total), DiagFileStats, DiagCpuMetr, DiagMemStats (2 packets total), DiagLtcData (4 packets total), RedLimAlrt LTC Telemetry: DiagLTC LMC Telemetry: cal_cnt, tkr_cnt, acd_cnt

The following LCI, LCM, LIM, LSM, LTC, PBC telecommands are used in this test.

LCI Telecommands

APID	FC Cmd. Packet (I)	Description (I)
0x67C	1 CALIBRATE	Initiate the calibration
0x67C	2 ABORT	Abort a running calibration

LCM Telecommands

APID	FC Cmd. Packet (I)	Description (I)
0x694	0 LLCMSCRUBRUN	Run Memory Scrubber
0x694	1 LLCMSCRUBCFG	Configure Memory Scrubber
0x694	2 LLCMERRORCFG	Configure CPU Error Handling
0x695	0 MsgResponse	Change task messaging level
0x695	1 CmdResponse	Change task command confirmation level
0x695	2 LLCMMODDUMP	Generate CPU Code Module Listing

0x695	3 LLCMTASKDUMP	Generate CPU Task Listing
0x696	0 LLCMPCIERRC	RAD750 PCI Error (Internal)
0x696	1 LLCMMEMERRC	RAD750 MEM Error (Internal)

LIM Telecommands

APID	FC Cmd. Packet (I)	Description (I)
0x661	0 LIMARRRESPONSE	ARR Response
0x661	1 LIMARRABORT	ARR Abort
0x662	1 LIMLOADSHED	Load Shed
0x663	0 LIMTOOSTART	TOO Start
0x663	1 LIMTOOABORT	TOO Abort
0x663	2 LIMHOLDENTER	Enter HOLD Mode
0x663	3 LIMHOLDEXIT	Exit HOLD Mode
0x663	4 LIMMAINFEEDON	Enable Main Power Feed
0x663	5 LIMSAFEMODE	Enter Safe Mode
0x663	6 LIMPOWERON	Enable Instrument Power
0x663	7 LIMPOWEROFF	Disable Instrument Power
0x663	8 LIMSAAENTER	Enter SAA
0x663	9 LIMSAAEXIT	Exit SAA

LSM Telecommands

APID	FC Cmd. Packet (I)	Description (I)
0x701	1 LSMSIAATTITUDE	SC Attitude Broadcast Message
0x701	2 LSMSIAANCILLARY	SC Ancillary Broadcast Message
0x701	3 LSMSIATIMETONE	SC Timetone Broadcast Message

LTC Telecommands

APID	FC Cmd. Packet (I)	Description (I)
-------------	---------------------------	------------------------

0x645	1 LTCRESTART	Restart and initialize Thermal Control
0x645	2 LTCSTART	Start control
0x645	3 LTCSTOP	Terminate Thermal Control processing
0x645	4 LTCSETMODE	Set thermal control mode to active or passive.
0x645	5 LTCHTRONOFFCNTL	Set heater to always on, or off or automatic control.
0x645	6 LTCSETPARAM	Set control parameters to new values.
0x645	7 LTCSETTLMFREQ	Set LTC telemetry frequency, 0 is off.

The following CTDB, ITC, LCI, LCM, LIM, PBC telemetry are used in this test.

CTDB Telemetry

APID	Tlm. Packet (L)	Description (L)
0x20E	LCTDBRTDIAG	CTDB 1553 RT Driver Diagnostics

ITC Telemetry

APID	Tlm. Packet (L)	Description (L)
0x2D0	CmdConfirm	Response to command from spacecraft

LCI Telemetry

APID	Tlm. Packet (L)	Description (L)
0x2D8	TERMINATE	Packet containing status of calibration

LCM Telemetry

APID	Tlm. Packet (L)	Description (L)
0x2D1	LLCMMODLIST	Module Status Dump
0x2D2	LLCMTASKLIST	Task Status Dump
0x2D3	LLCMPCIERR	RAD750 PCI Error Report
0x2D4	LLCMEMERR	RAD750 MEM Error Report

LIM Telemetry

APID	Tlm. Packet (L)	Description (L)
0x30F	State	Current LIM State

1.2 Test ID

CMDFNC_003

Test *CMDFNC_003* contains one main script, *CMDFNC_003*, which can be run when the SIU is in the Boot or Application Mode. This test verifies that FSW can exchange command and telemetry on the 1553 bus. It also verifies that the FSW checks for data integrity errors and performs command validation before execution of commands. Additionally, it verifies that command execution and completion status are reported in telemetry.

1.3 Requirement(s) Tested

The Qualification Test Procedure described herein is performed to verify that the FSW satisfies the following requirement(s), quoted from the Flight Software Specification – Level III:

Requirement Number	Requirement Name	Requirement	Level of Requirements Verification in This Test
5.2.2.1.1	Command, Telemetry, and Data Bus Protocol - SC	The SIU FSW shall exchange commands, low rate telemetry, time messages, and ancillary data with the SC C&DH across a MIL-STD-1553B bus, using the MIL-STD-1553B physical layer protocol.	Partial (CMDFNC_003 tests for proper format, transmission and execution of a subset of telecommands and also tests for <i>rejection</i> of invalid versions of all other telecommands (see Section 1.1.1 above),
5.2.2.1.3	Data Format	All data exchanged across the CTDB interface shall be formatted as CCSDS telecommand or telemetry packets, as specified.	Partial (CMDFNC_003 tests for command format validation for a subset of telecommands, with valid command headers, and also tests for <i>rejection</i> of commands with invalid command headers for all other telecommands . (see Section 1.1.1 above),
5.3.3.5	Command Format	The FSW shall be able to process commands of the format described in LAT Flight Software Telecommand and Telemetry Formats	Partial (CMDFNC_003 tests for command format validation for a subset of telecommands, with valid command format, and also tests for <i>rejection</i> of commands with invalid command format for all other telecommands . (see Section 1.1.1 above),

Requirement Number	Requirement Name	Requirement	Level of Requirements Verification in This Test
5.3.3.9.1	Data Integrity Errors	To reduce the chance of executing a corrupted command, the FSW shall validate commands prior to execution.	Partial (CMDFNC_003 tests for proper data format, for a subset of telecommands, with valid data and also tests for <i>rejection</i> of commands with invalid data for all other telecommands . (see Section 1.1.1.above),
5.3.3.9.2	Parameter Validation	The SIU FSW shall validate command parameters prior to execution.	Partial (CMDFNC_003 tests for command parameter validation for a subset of telecommands, with valid parameters, and also tests for <i>rejection</i> of commands with invalid parameters for all other telecommands . (see Section 1.1.1.above),
5.3.3.1	SC Command Processing by SIU	The SIU FSW shall process LAT commands from the SC, received via the CTDB, in the order that they are received.	Partial (CMDFNC_003 tests for command processing order for a subset of telecommands, (see Section 1.1.1.above),
5.3.3.2	Command Execution Notification	For all LAT commands from the SC, the FSW shall be capable of generating time-tagged telemetry notification of their dispatch for execution.	Partial (CMDFNC_003 tests for command execution notification for a subset of telecommands, (see Section 1.1.1.above),
5.3.3.3	Command Completion Status	The FSW shall be capable of generating time-tagged telemetry notification of command completion status (success or general cause of failure) for ground-initiated commands at the time such information becomes available. As a goal, in addition to completion status, each successful command should result in a modification of a telemetry parameter (e.g., Off to On, Open to Closed, etc.) to further confirm success.	Partial (CMDFNC_003 tests for command completion status for a subset of telecommands, (see Section 1.1.1.above),
5.3.14	Ancillary Data from SC (at 1Hz)	The SIU FSW shall receive and process ancillary data packets from the SC, delivered at 1 Hz via the CTDB.	Full.
5.2.2.1.2	Command Rates	The SIU FSW shall receive commands across the CTDB at a rate of up to 20 commands per second.	Partial (CMDFNC_003 tests for command rates for a subset of telecommands, (see Section 1.1.1.above),

This test also shares verification of certain requirements with the NBTLMV suite. The requirements partially verified in this test are listed below.

Requirement Number	Requirement Name	Requirement	Level of Requirements Verification in This Test
5.3.5.2	Diagnostic Telemetry	<p>[Derived]</p> <p>The FSW shall send diagnostic telemetry messages, as defined in [9], to the SC via the CTDB.</p> <p>Diagnostic telemetry is sent in response to a command and downlinked immediately while the SC is in contact with the ground. If not in contact, the telemetry is written to the solid-state recorder on the spacecraft.</p>	<p>Partial</p> <p>(CMDFNC_003 verifies that telemetry packets transmitted by the CTDB, LCI, LCM, ITC, LIM, LTC and PBC FSW have APIDs in the diagnostic telemetry APID range and that these packets are delivered over the CTDB, as required. Transmission of other diagnostic telemetry is covered by the NBTLMV test suite)</p>

If the requirement(s) quoted above cite external documents (e.g., "...Further details are provided in [11]"), consult LAT-SS-00399 for the list of citations.

2. **DEFINITIONS AND ACRONYMS**

The following terms, abbreviations, and acronyms are used in this document:

2.1 **Definitions**

Hz	Hertz, unit of frequency
V	Volt
W	Watt
s, sec	seconds

2.2 **Acronyms**

CAL	Calorimeter
EGSE	Electrical Ground Support Equipment
GASU	Global trigger Anti-collision Spacecraft Unit
PTR	Post Test Review
TEM	Tower Electronics Module
TKR	Tracker
TPS	Tower Power Supply
TRR	Test Readiness Review
QAE	Quality Assurance Engineer
TE	Test Engineer

3. REFERENCES

The list below provides documents that are to be used as references for this procedure:

3.1 **Applicable Documents**

<u>Document Number</u>	<u>Description</u>
<u>SPECIFICATIONS</u>	
LAT-SS-00399	LAT Flight Software Level III Specification
1196 EI-S46310-000	GLAST 1553 Bus Protocol Interface Control
LAT-TD-02659	LAT Flight Software Telecommand and Telemetry Formats
LAT-TD-0561	The Virtual Spacecraft (VSC)
<u>PROCEDURES</u>	
N/A	
<u>PLANS</u>	
LAT-MD-00039	Performance Assurance Implementation Plan
LAT-MD-00078	GLAST LAT System Safety Program Plan
LAT-MD-00404	LAT Contamination Control Plan
LAT-MD-00408	LAT Program Instrument Performance Verification Plan
LAT-SS-00296	T & DF Test Plan
LAT-TD-00297	LAT Electronics Test Plan
LAT-TD-00786	LAT Flight Software Test Plan
LAT-MD-00104	LAT FSW Management Plan
<u>DRAWINGS</u>	
N/A	
<u>OTHER</u>	
LAT-MD-00091	GLAST Quality Manual
LAT-MD-00471	Control of Nonconforming Product
LAT-MD-00472	Corrective and Preventative Action

4. REQUIREMENTS

This section lists the requirements that shall be followed during the LAT FSW Qualification Testing process.

The Performance Assurance Implementation Plan, LAT-MD-00039, shall be utilized to ensure that the products produced by the GLAST LAT project intended for design qualification, flight and critical ground support equipment usage meet the required levels of quality and functionality for their intended purposes.

The LAT Program Instrument Performance Verification Plan, LAT-MD-00408, shall be utilized to address the testing to be performed at the unit/subsystem and instrument level for flight qualification, proto-flight and acceptance testing phases. Also included are the necessary processes/procedures and systems assurance activities.

4.1 Test Data, Equipment and Software

This procedure shall follow the requirements found in the Control of Nonconforming Product, LAT-MD-00471. This document establishes the method to identify and control nonconforming product developed by the LAT project team.

4.2 Quality Assurance

This procedure shall follow the requirements found in the Corrective and Preventative Action document, LAT-MD-00472 and the GLAST Quality Manual, LAT-MD-00091.

The Corrective and Preventative Action document establishes the method to be used to initiate, implement, evaluate and record corrective and preventive actions. The GLAST Quality Manual defines the methods implemented by the GLAST LAT project to ensure consistent quality of all processes for procurement, design, development and production of flight hardware, flight software and all associated ground support equipment interfacing with flight hardware and software.

4.3 Safety

This procedure shall follow the requirements found in the GLAST LAT System Safety Program Plan, LAT-MD-00078. This document defines all phases of the LAT program including: design, development, fabrication, handling, transportation, storage, test, assembly and operation.

WARNING: When high voltages are present extreme care should be exercised.

4.4 Warnings, Cautions, and Notes

The following SAFETY ALERTS are intended to create awareness of the potential safety hazards and the steps that must be taken to avoid accidents. These same alerts are used throughout this document to identify specific hazards that may endanger personnel and/or equipment.

Identification of every conceivable hazardous situation is impossible. Therefore, all personnel have the responsibility to diligently exercise safe practices whenever exposed to this equipment.

WARNING: Indicates a potential hazardous situation which, if not avoided, could result in death or injury.

CAUTION: Indicates a potential hazardous situation which, if not avoided, could result in damage to equipment.

Note: Indicates a notification of information that is important, but not hazard related.

4.5 General Instructions

This qualification test procedure shall be conducted on a formal basis to its latest approved and released version. The designated Software QAE shall be notified 24 hours prior to the start of this procedure. Software QAE may monitor the execution of all or part of this procedure should they elect to do so.

The Test Engineer conducting this test shall read this document in its entirety and resolve any apparent ambiguities before beginning the procedures described herein.

Deviations from the procedures described in this document and breaks in hardware or software configuration can only be initiated by the Test Engineer, must be approved by QA, and must be documented in Appendix A.

Any nonconformance/defect/anomaly is to be reported in JIRA. Refer to the LAT Flight Software Test Plan LAT-TD-00786 for guidance. Do not alter or break configuration if a failure occurs. Notify Software Quality Assurance.

All success conditions for a test must be met for the test to pass.

5. SETUP

This section describes the hardware and software configuration used for the qualification test described later in this document. Any break from configuration or deviation from a particular procedure must be authorized by the Quality Assurance Engineer and documented in Appendix A.

5.1 Hardware Setup

The list below indicates the equipment that is used to execute the tests described in this document.

Hardware Unit	Manufacturer	GLAT Number (and Hardware Sub-Units by GLAT Number)	Firmware Version (where applicable)
Virtual Spacecraft (VSC)			
Spacecraft Interface Unit (SIU)			
Event Processing Unit (EPU): 2 (EPU0 and EPU1)			
Global trigger, AEM Signal Distribution Unit (GASU)			
Power Distribution Unit (PDU)			
1553 cables and couplers			
Unix or Linux Host Establishes connection between VSC and the terminal from which the test is run.			
Power supply for SIU			

The Figure below depicts the Testbed on which this qualification test is performed. The particular hardware units utilized in this test are itemized by GLAT number and firmware version in the

preceding table.

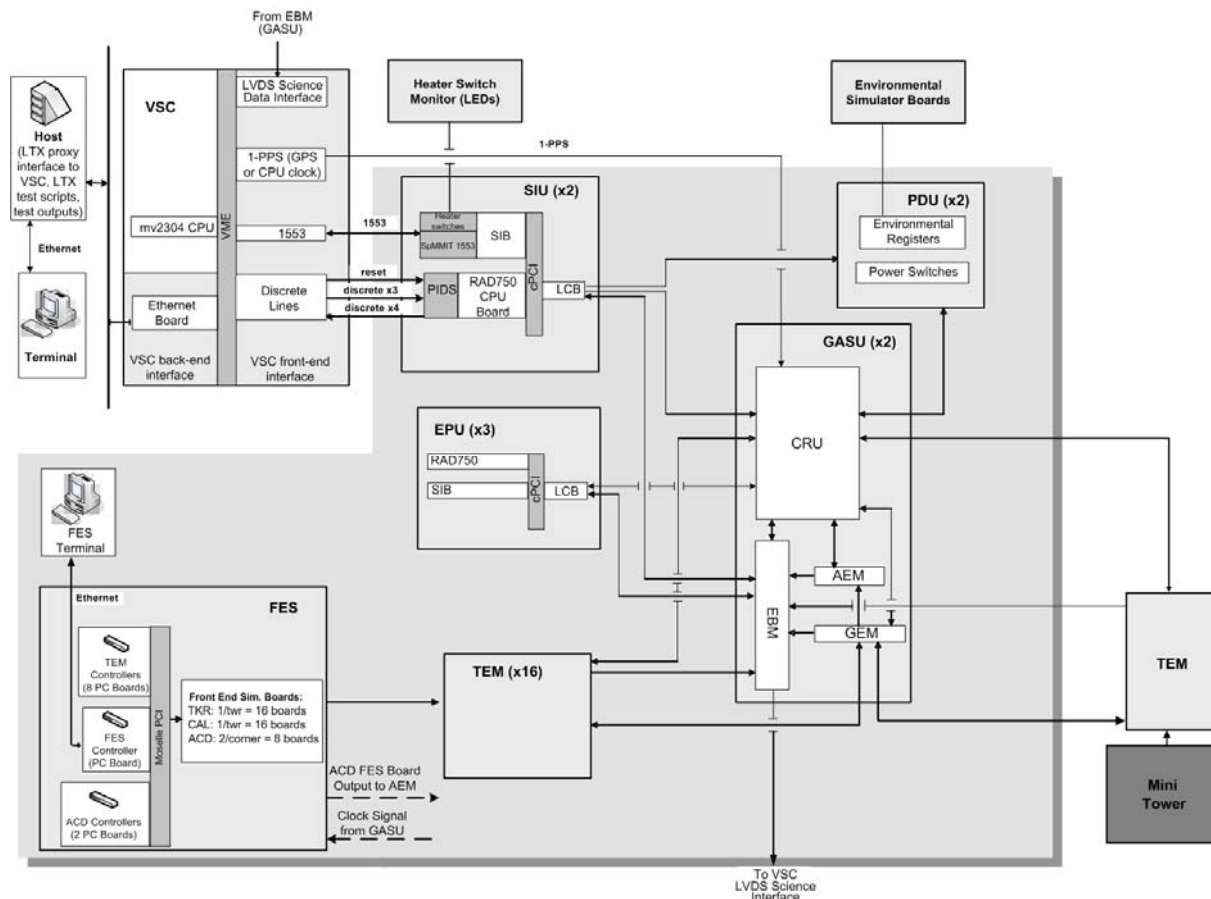

Figure 1. FSW Testbed

5.2 Software Setup

The software required to prepare for and execute the tests described in this Qualification Test Procedure document is itemized in this section.

5.2.1 Test Tools

The following table specifies the test executive used to run this qualification test, and identifies the other software tools used to support the execution of the test. The “Software Version Number” column identifies the version number of the test tool being used; alternatively, this column identifies the hardcopy attachment to this document that records the version of the tool being used (e.g., “Attachment 1”). The “Path to Attachment” column identifies the directory in which the electronic copy of any hardcopy attachment is saved (if applicable).

Software	Description of Software	Software Version Number (or Specify Attachment Number)	Path to Attachment (If Applicable)
LTX	LAT Test Executive		
VSC	Virtual Spacecraft system software		
VPI	VSC Python/Proxy Interface		

5.2.2 Test Scripts

The following table identifies the test scripts that are run to execute this qualification test. The “Script Version Number” column identifies which version of the script is being used; alternatively, this column identifies the hardcopy attachment to this document that records the version of the script being used (e.g., “Attachment 1”). The “Path to Attachment” column identifies the directory in which the electronic copy of any hardcopy attachment is saved (if applicable).

Test Script	Description of Test Script	Script Version Number (or Specify Attachment Number)	Path to Attachment (If Applicable)
CMDFNC_003.py	This script, the main test execution script, can be run in the SIU Boot or Application Modes. It executes tests of SIU FSW.. The script controls the entire test process, detecting the state of the hardware and FSW and advancing SIU FSW through the different operational modes covered during the test.		

5.2.3 Flight Software

This qualification test is performed on a complete, integrated Candidate Release of FSW. All FSW libraries under test are final Flight Unit Candidate versions. The test described in this document is designed to evaluate the particular FSW packages and constituents listed in the following table; for clarity, only those constituents that are the focus of the test are listed below.

FSW Package	Constituent(s)
CTDB	
ITC	

FSW Package	Constituent(s)
LCM	
LIM	
LSM	

The Candidate Release into which these FSW constituents are integrated is identified in the following table. The “Candidate Release Build Number” column specifies the build number of the FSW Candidate Release under test (e.g., “B0-0-1”). The “Candidate Release Attachment Number” column identifies which hardcopy attachment to this document confirms the name and version number of the full set of FSW packages and constituents used in the test (e.g., “Attachment 2”). The “Path to Attachment” column specifies where in the test repository an electronic copy of the hardcopy attachment has been saved.

Candidate Release Build Number	Candidate Release Attachment Number	Path to Attachment

5.3 Setup Validation

5.3.1 Hardware Validation

The following signatures confirm that the Test Engineer and Quality Assurance Engineer have verified the GLAT numbers, firmware version numbers, and the proper connection of all hardware listed in the table in Section 5.1.

 Date Time Test Engineer QAE

5.3.2 Software Validation

The Test Engineer performs the following procedure to validate the software setup for this qualification test and records completion of the setup validation steps in the space provided.

Step No.	Description of Step	Step Outcome
1	Record the version numbers of all test tools used to perform this qualification test in the table in Section 5.2.1	Complete/ Not Complete
2	Record the version numbers of all test scripts used to perform this qualification test in the table in Section 5.2.2	Complete/ Not Complete
3	Record the version numbers of the FSW constituents and the Candidate Release on which this test is performed in Section 5.2.3.	Complete/ Not Complete

The following signatures confirm that, using the procedure described in the previous table, the Test Engineer and Quality Assurance Engineer have verified that all versions of test support software, test scripts, and FSW constituents match those identified in Section 5.2.

Date

Time

Test Engineer

QAE

6. **TEST PROCEDURE FOR CMDFNC_003**

6.1 Test Objective

The following are the objectives of this test when tested in the Boot or Application Modes.

This test verifies that FSW is capable of exchanging commands, low-rate telemetry, time messages and ancillary data over the 1553 Bus. It also verifies that such data has data integrity, and that commands are validated prior to execution.

This Test Objective is broken down into the following Test Sub-Objectives.

Number	Test Sub-Objective
1	Verify all operations on SIU.
2	Verify all operations in both the Boot and Application Modes.
3	Verify all operations in both the Primary and Redundant SIUs.
4	Verify all Telecommands and Telemetry exchanged over the 1553 bus in conjunction with other Test Suites as described in Section 1.1.1
5	Verify that the Telecommands and Telemetry exchanged across the 1553 Interface conform to the CCSDS packet structure.
6	Verify that all supported Telecommands issued by S/C with LAT as their destination are received correctly and processed. Verify that Telecommands with valid Headers and Parameters are accepted and processed by FSW. This verification is done in conjunction with various Test suites as indicated in section 1.1.1

Number	Test Sub-Objective
	Verify that Telecommands with invalid Headers and Parameters are rejected by FSW. This test will be implemented subject to the constraint that the FSW and VSC tools allow the generation and transmission of such invalid commands and such test implementation does not require an inordinate amount of time or effort.
7	Verify all Telemetry resulting from the commands above for CCSDS conformance.. Verify that Telemetry with valid Headers, and Payload are sent by FSW. This verification is done in conjunction with various Test suites as indicated in section 1.1.1
8	Verify that SIU FSW processes LAT commands from the SC in the order that they are received. This verification is done in conjunction with various Test suites as indicated in section 1.1.1
9	Verifies that for all LAT commands from SC, the FSW is capable of generating time-tagged telemetry notification of their dispatch for execution. This verification is done in conjunction with various Test suites as indicated in section 1.1.1
10	Verifies that FSW is capable of generating time-tagged telemetry notification of command completion status (success or general cause of failure). This verification is done in conjunction with various Test suites as indicated in section 1.1.1
11	Verifies that SIU FSW is able to receive and process ancillary data packets from SC delivered at 1 Hz. Verified in the Application Mode.
12	Verifies that SIU FSW receives commands at the rate of up to 20 commands per second. Verified in the Application Mode only. Boot Mode Verification is done in MEMMGT_001.

As explained in Section 1, the CMDFNC_003 test is related to tests in the NBTLMV suite.

CMDFNC_003 partially verifies the diagnostic telemetry requirements, thus the following are also listed as Test Objectives and are verified in this test.

Number	Test Sub-Objective
1	Verify that FSW transmits telemetry packets with APIDs in the diagnostic telemetry range and that this telemetry is delivered over the CTDB interface.

Analysis of results is performed as and when data arrives in telemetry. Typically analysis includes verifying the telemetry values against expected values and tagging the sub-objectives as either “PASS” or “FAIL”.

6.2 Test Input Files

The following table identifies all auxiliary files (e.g., Front End Simulator data files, GLEAM data files) used as inputs to this qualification test. Note that not all qualification tests use input data of this type. The “Input File Version Number” column identifies the version number of the auxiliary file being used; alternatively, this column identifies the hardcopy attachment to this document that

records the version of the file being used (e.g., “Attachment 1”). The “Path to Attachment” column specifies where in the test repository an electronic copy of the hardcopy attachment has been saved .

Input File	Description of Input File	Input File Version Number (or Specify Attachment Number)	Path to Attachment (If Applicable)
N/A	N/A	N/A	N/A

6.3 Test Output Files

The following table identifies all files used as outputs to this qualification test. Note that not all qualification tests use output data of this type. The “Output File Version Number” column identifies the version number of the auxiliary file being used; alternatively, this column identifies the hardcopy attachment to this document that records the version of the file being used (e.g., “Attachment 1”). The “Path to Attachment” column specifies where in the test repository an electronic copy of the hardcopy attachment has been saved.

Output File	Description of Output File	Output File Version Number (or Specify Attachment Number)	Path to Attachment (If Applicable)
TBD.csv	Telemetry mnemonic archive files generated by VSC proxy interface (VPI)		
TBD0.out	Telecommand transaction file containing analysis of test and telecommands and telemetry.		

6.4 Test Preparation

After the hardware and software setup has been validated, steps may be required to place the hardware and FSW in an operational mode in which the qualification test can be performed or otherwise complete preparations for the test to begin.

The Test Engineer carries out the following procedure to prepare for qualification testing and records completion of the test preparation steps in the space provided.

Step No.	Description of Step	Step Outcome
1	Confirm that the VSC is powered up.	Complete/ Not Complete
2	Confirm that the SIU and the GASU are powered up: The voltage indicator on the SIU/GASU Xantrex power supply should display $28 \pm 0.2V$. The SIU feed "POWER ON" switch on the regulated feeds bus protection unit (BPU) should be flipped "ON". The SIU voltage indicator on the BPU should display $28 \pm 0.2V$. The SIU current as shown by the BPU indicator should be above 0.4A The DAQ feed "POWER ON" switch on the BPU should be flipped "ON". The DAQ voltage indicator on the BPU should display $28 \pm 0.2V$.	Complete/ Not Complete

The Test Engineer and Quality Assurance Engineer verify that all test preparation steps are complete.

 Date

 Time

 Test Engineer

 QAE

6.5 Test Procedure and Test Analysis

This section describes the step by step procedure performed once the test preparation is complete. The test as well as analysis for each of the sub-objectives is conducted by the main test script CMDFNC_003.

After the test setup has been validated, and test preparation steps are complete, the Test Engineer proceeds with the qualification test procedure itself, as described below, and records the outcome of each step during test execution. The outcome of each step is either "Complete" or "Not Complete" (for steps which involve no analysis or verification); or, "Pass" or "Fail" (for steps involved in verifying completion of test objectives and sub-objectives).

The test procedure is executed on the SIU and EPU's in both Boot Mode and Application Mode, in 7 major parts:

- SIU Boot Mode Testing
- SIU Application Mode Testing
- Review of Test Outputs

6.5.1 Part 1: SIU Boot Mode Testing

This part of the test confirms that valid Boot Mode telecommands sent over the 1553 interface are correctly accepted and processed by SIU FSW.

Step No.	Description of Step	Step Outcome
1	At the test terminal, run the script <i>CMDFNC_003</i> under LTX through the VSC with the following command: \$ ltx run CMDFNC_003	Complete/ Not Complete
2	The script initializes the VSC software and starts proxy interface. Output file TBD.csv is created in the test session directory and the full path and filename of the soft copy of this output file is recorded in section 6.3 of the procedure document.	Complete/ Not Complete
3	The test script determines whether the SIU is powered on by checking whether SIU boot housekeeping telemetry is being transmitted. Regardless of the SIU's current operational mode, the script sends the SIU the LPBCRESET telecommand to reboot the unit. The script then checks whether the SIU FSW is operating in Boot Mode by detecting if boot housekeeping is being transmitted. If not, the script sends the LPBCRESET command and checks again. If the SIU FSW cannot be placed in Boot Mode, LTX prints an error message to the screen and exits, aborting the test. If the test is NOT aborted, mark "Complete" for the Step Outcome.	Complete/ Not Complete
4	With FSW on the SIU advanced to Boot Mode, the test script begins executing its SIU Boot Mode Command Data Format and Integrity Phase. The following commands are sent: LPBCSTART, LPBCRESET and PBCERRDUMP. The script sends the above Boot Mode commands with bad Headers/Checksum and verifies failure of dispatch for execution. Check SIU Boot Housekeeping Telemetry LBTHKP for the following fields: LPBCTOTALERRCNT, LPBCTCACCCNT for failure. TOTALERR is incremented for invalid commands. BOOTPKTACCEPT does not change that indicates that the command was invalid, hence not accepted or processed.	N/A
5	The test script next executes its SIU Boot Mode Command Format and Parameter Validation phase. The test script sends the same Boot Mode Commands sent in Step 4 with invalid parameters and verifies that such telecommands are rejected by FSW. Bad parameter values include incorrect or out of range values in payload fields and an incorrect number of parameters. Check the SIU boot housekeeping (LBTHKP packets). Verifies by checking the LPBCLASTFUNC and LPBCLASTAPID fields in this telemetry to contain the APID and FUNC code of the command last sent. The error fields LPBCTCACCCNT, LPBCTCREVCNT, LPBCTOTALERRCNT, LPBCNEXTERRWORD, LPBCLASTERRWORD indicate failure of the commands.	N/A

Step No.	Description of Step	Step Outcome
6	<p>The test script next executes its SIU Boot Mode Command Completion Status Phase.</p> <p>Verifies that FSW is capable of generating time-tagged telemetry notification of command completion status (success or general cause of failure).</p> <p>In Steps 4 and 5, the test checks that command completion status is reported by FSW, using the telemetry fields in the Boot Housekeeping Telemetry. The complete analysis of command parameter validation based on the results of Steps 4 and 5 is recorded in the output log printed and reviewed at the end of the test.</p>	N/A

6.5.2 SIU Application Mode Testing

This part of the test confirms that telecommands sent to the LAT are received, forwarded, and processed by SIU FSW operating in Application Mode.

For each of the telecommands sent to SIU during this part of the test, a Command Verification (CmdConfirm) telemetry packet is received, which is further analyzed to verify the status of the reception and execution of the commands. The test script examines the ITC_NODE, ITC_TASK, and ITC_EXESTATUS fields in these packets, as well as the CmdHeader field (in which the CCSDS header of each telecommand sent to SIU FSW is reflected).

This part also verifies that invalid Application Mode telecommands of all other types are rejected. See Section 1.1.1

Step No.	Description of Step	Step Outcome
7	<p>The test script advances the SIU FSW to Application Mode by sending the LPBCRTOSEXEC telecommand, which commands the SIU to perform a secondary boot.</p> <p>The script checks that the SIU is operating in Application Mode by detecting whether Application Mode housekeeping telemetry is being transmitted. If not, the script sends the LPBCRTOSEXEC command and checks again.</p> <p>If the SIU FSW cannot be placed in Boot Mode, LTX prints an error message to the screen and exits, aborting the test.</p> <p>If the test is NOT aborted, mark "Complete" for the Step Outcome.</p>	Complete/ Not Complete

Step No.	Description of Step	Step Outcome
8	<p>The test script begins executing its SIU Application Mode Data Format and Integrity Errors phase. In this Step, the script tests for correct processing of valid commands listed in section 1.1.1.</p> <p>The telecommands that are listed under the packages LCI, LCM, LIM, LSM, LTC in section 1.1.1 are sent sequentially with valid Headers and Checksums. Command Verification Telemetry received for each of these commands are analyzed to confirm success of reception and processing.</p> <p>The various incoming Telemetry sent by FSW in response to any of these commands are also examined for CCSDS conformance for Header values.</p> <p>The test script continues its SIU Application Mode Data Format and Integrity Errors phase. In this Step, the script tests for rejection of invalid telecommands. All the supported telecommands are sent with invalid headers and checksums. Command Verification Telemetry received for each of these commands are analyzed to confirm rejection.</p>	N/A
9	<p>Next, the script executes its SIU Application Mode Command Format and Parameter Validation phase. In this Step, the script tests for correct processing of command with valid parameters. All the telecommands that are listed under the LCI, LCM, LIM, LSM (that include Attitude, Ancillary and Timetone Broadcast messages), LTC in section 1.1.1 are sent sequentially with valid Parameters. Command Verification Telemetry received for each of these commands are analyzed to confirm success of reception and processing.</p> <p>The various incoming Telemetry sent by FSW in response to any of these commands are also examined for CCSDS conformance for Payload values.</p> <p>Next the script tests for rejection of invalid telecommands.</p> <p>Verification that Telecommands with invalid Parameters are rejected by FSW is performed in this test for all supported commands. Bad Parameter values include incorrect or out of range values for the Payload fields and incorrect number of parameters. Verifies by sending commands with unacceptable Parameters and noting failure of dispatch for execution returned as status code messages in the Command Verification Telemetry .</p>	N/A
10	<p>Next, the script executes its SIU Application Mode Command Processing Order phase.</p> <p>For all of the commands sent out in steps 8 and 9, it is verified that the Deque time (deq_msui and deq_lsui fields) returned in the Command Verification Telemetry is in the same increasing order as the commands sent from SC.</p>	N/A
11	<p>Next, the script executes the SIU Application Mode Command Execution Notification phase.</p> <p>For all of the commands sent out in steps 8 and 9, it is verified that the there are Dispatch for Execution timestamps (exec_msui and exec_lsui) received in the Command Verification Telemetry for each of the command sent.</p>	N/A
12	<p>Next the script executes the SIU Application Mode Command Completion Status phase.</p> <p>For all of the commands sent out in steps 8 and 9, it is verified that the Status field in the received Command Verification Telemetry for each of the command sent, contains the correct SUCCESS/ERROR or other status codes.</p>	N/A

Step No.	Description of Step	Step Outcome
13	<p>Next the script executes the SIU Application Mode Command Rates phase.</p> <p>20 commands comprising a mixture of different commands are issued within one second.</p> <p>Verified by receiving the CmdConfirm Telemetry for all the 20 commands and noting that all 20 of them were correctly received and dispatched for execution.</p>	N/A
14	<p>Next the script executes the SIU Application Mode Ancillary Data Reception from Spacecraft phase.</p> <p>The LSM commands LLSMSIANCILLARY, LLSMSIATTITUDE and LLSMSITIMETONE are issued. STATUS codes in Command Verification Telemetry are used to verify that these are received and processed correctly.</p>	N/A
13	<p>The script issues the LPBCRESET command to reboot the SIU.</p> <p>The script then checks whether the SIU FSW is now operating in Boot Mode. If not, the script sends the LPBCRESET command and checks again.</p> <p>If the SIU FSW cannot be placed in Boot Mode, LTX exits.</p> <p>Confirm that the script has placed the SIU in Boot Mode ready for another test.</p>	Complete/ Not Complete

6.5.3 Part 7: Review of Test Outputs

Step No.	Description of Step	Step Outcome
1	<p>After the CMFNC_003 test script has executed all parts of the test described in the previous sections, a dialogue box appears, reporting the directory location to which the test log output file is saved and instructing the test engineer to print the file for review.</p> <p>Print the log file, retrieve it from the printer, label it, and attach it to this test procedure.</p> <p>Record the label written on the printed log file: _____</p> <p>Record the full path and filename of the soft copy of this output file: _____</p>	Complete/ Not Complete

Step No.	Description of Step	Step Outcome
3	<p>Review the log file. The file contains detailed outputs of the test script, with the names of telecommands being issued, telemetry packets being received, telemetry fields being examined, and status summaries of each major step in the test</p> <p>The following log file entries appear interspersed through the log file, followed by “PASS” or “FAIL”.</p> <p>Boot Mode Command Data Format and Integrity Errors</p> <p>Boot Mode Command Format and Parameter Validation</p> <p>Boot Mode Command Completion Status</p> <p>CMDFNC_003(1): Passed</p> <p>Confirm that each of the above entries appears in the log file with a “PASS” indication.</p> <p>Successful completion of this step verifies all test objectives and sub-objectives for Boot Mode.</p>	Pass/ Fail
8	<p>Review the log file. The file contains detailed outputs of the test script, with the names of telecommands being issued, telemetry packets being received, telemetry fields being examined, and status summaries of each major step in the test.</p> <p>The following log file entries appear interspersed through the log file, followed by “PASS” or “FAIL”.</p> <p>Application Mode Data Format and Integrity Errors</p> <p>Application Mode Command Format and Parameter Validation</p> <p>Application Mode Command Processing order</p> <p>Application Mode Command Execution Notification</p> <p>Application Mode Command Completion Status</p> <p>Application Mode Command Rates</p> <p>Application Mode Command Execution</p> <p>Application Mode Ancillary Data Reception</p> <p>Application Mode Diagnostics Telemetry Verification</p> <p>CMDFNC_003(2): Passed</p> <p>Confirm that each of the above entries appears in the log file with a “PASS” indication.</p> <p>Successful completion of this step verifies all test objectives and sub-objectives for Application Mode.</p>	Pass/ Fail

Initial to confirm.

Date Time Test Engineer QAE

7. TEST POST CONDITIONS AND OVERALL OUTCOME

7.1 Test Post-Conditions

The following post-conditions are analyzed and verified by the test script as described in “Test Procedure and Test Analysis”:

No.	Post-Condition	Post-Condition Met? (Yes/No)
1	SIU in Boot Mode	

The Test Engineer and Quality Assurance Engineer verify that all test post-conditions are met.

_____ Date _____ Time _____ Test Engineer _____ QAE

7.2 Overall Outcome of CMDFNC_003

Based on the analysis of the test results, the overall outcome of Test CMDFNC_003 is as follows:

- Passed** - all of the expected outcomes for the test were confirmed
- Failed** - one or more of the test outcomes were not confirmed

_____ Date _____ Test Engineer _____ QAE

8. CERTIFICATION

I certify that the information obtained under this test procedure is as represented and the information recorded in this document is complete and correct. Any deviations from test procedures described herein are identified in Appendix A.

Date Test Engineer (Print Name) Test Engineer (Signature)

I certify that the information obtained through execution of this test procedure is as represented and the information recorded in this document is complete and correct. Execution of the test, storage of the results, and verification of outcomes were carried out in accordance with quality standards defined in the GLAST Quality Manual (LAT-MD-00091).

Date Software QA Engineer (Print Name) Software QA Engineer (Sign)

I certify that the information obtained under this test procedure is as represented and the information recorded in this document is complete and correct. The test procedure, as designed and executed, does indeed verify that the FSW functionality under test satisfies the corresponding requirements from the Flight Software Specification – Level III.

Date FSW Manager (Print Name) FSW Manager (Signature)

APPENDIX A: DEVIATIONS FROM THE QUALIFICATION TEST PROCEDURE

This section details any deviations from the hardware configuration, software configuration, or test procedure followed during the execution of the test or tests described in this Qualification Test Procedure document. All deviations from the approved procedure are agreed to by the Test Engineer and the Software Quality Engineer during the test execution session. All deviations must be reported during the Post Qualification Test Review, where their impact on the test results will be evaluated.

Hardware Deviations

Describe any deviations from the hardware configuration defined in Section 5.1. Name the hardware that was modified and describe the modifications. If hardware is *replaced* during execution of the test, name the replaced hardware, the manufacturer, and list an identification number (e.g., GLAT ID number).

Software Deviations

Describe any changes made to the software configuration under test or the software configuration used to support test execution, as defined in Section 5.2. Give version numbers of all FSW packages and test packages that were modified. Describe how the contents of the modified software load were verified. Describe these deviations for each test that was modified.

Procedural Deviations

Specify any deviations from the test procedure for the test being executed. If this document contains more than one test procedure, list the procedure by number (e.g., “CMDFNC_003”). List by number the steps modified or skipped. Provide a numbered sequence listing any added steps. Describe these deviations for each test that was modified.
