



LAT Flight Software

LAT Housekeeping (LHK)

Number: LAT-TD-02905

Subsystem: Data Acquisition/Flight Software

Supersedes: None

Type: Design Document/User Manual

Author: S.Maldonado

Created: 26 August 2003

Updated: 9 May 2007

Printed: 9 May 2007

This document describes the collection, evaluation, and transmission of the LAT instrument housekeeping data.

Document Approval

Prepared By:

S.Maldonado

LAT Flight Software

Date

Approved By:

G.Haller

LAT Electronics Manager

Date

Approved By:

J.J.Russell

LAT Flight Software Manager

Date

Contents

0	Introduction	1
0.0	Overview	1
0.1	Definitions and Acronyms	1
0.2	Reference Documentation	2
1	Health and Status Data	3
1.0	Hardware Values	3
1.0.0	Environmental Monitoring	3
1.0.0.0	TEM Environmental Monitors	3
1.0.0.1	TEM Current Calculation	5
1.0.0.2	TEM Conversion Constants	5
1.0.0.3	PDU Environmental Monitors	6
1.0.0.4	PDU Power Management	7
1.0.0.5	AEM Environmental Monitors	8
1.0.0.6	AEM Free Board Power Management	9
1.0.1	Low Rate Science	9
1.0.1.0	GLT Electronics Module (GEM) Low Rate Science	9
1.0.1.0.1	Livetime	9
1.0.1.0.2	Dead-Zoned	9
1.0.1.0.3	Window Turns	10
1.0.1.1	Event Builder Module (EBM) Statistics	10
1.0.2	CPU Metrics	11
1.1	Software Metrics	11
1.1.0	Inter-task Communications (ITC) Statistics	11
1.1.0.0	Telecommand Counters	11
1.1.0.1	Task Messaging Configuration	13
1.1.1	File System (FILE) Statistics	14
1.1.2	Memory System (MEM) Statistics	15
1.1.3	1553 Remote Terminal (CTDB) Statistics	16
1.1.4	LAT Instrument Mode Control (LIM) Statistics	17
1.1.5	LAT Thermal Control (LTC) Statistics	18
1.1.6	LAT Configuration (LATC) Statistics	19
1.2	Summary	20
2	Implementation	21
2.0	Overview	21
2.1	Data Acquisition	21
2.1.0	Data Flow	22
2.2	Command Handler	22
2.3	Scheduler	22
2.3.0	Schedule Execution	23
2.3.0.0	Acquisition Schedule	23
2.3.0.1	Housekeeping Packet Schedule	24
2.3.0.2	Diagnostic Packet Schedule	24
2.4	EPU Slave Processing	24

2.5	Limit Threshold Evaluation	24
2.5.0	Status Codes/Alarm Categories	24
2.5.1	Limit Table	25
3	Package Description.....	26
3.0	Shareables	26
3.1	Executables	26
3.2	Utilities	26
4	Programming.....	27
4.0	Initialization	27
4.1	Application Control	27
5	Configuration	28
5.0	LHK_DB Files	28
5.1	XML File Types.....	28
5.1.0	Scheduler Table Configuration.....	28
5.1.0.0	pkt_sched	29
5.1.0.1	acq_sched	29
5.1.0.2	sched_enab.....	31
5.1.0.2.1	tem_adc_enab	31
5.1.0.2.2	tem_lrs_enab	31
5.1.0.2.3	aem_adc_enab	31
5.1.0.2.4	pdu_adc_enable	31
5.1.0.2.5	pdu_reg_enab	31
5.1.0.2.6	gem_lrs_enable	31
5.1.0.2.7	ebm_stat_enab	32
5.1.0.2.8	comm_stat_enab	32
5.1.0.2.9	file_stat_enab.....	32
5.1.0.2.10	cpu_met_enab	32
5.1.0.2.11	rt_stat_enab	32
5.1.0.2.12	mem_stat_enab	32
5.1.0.2.13	ltc_stat_enab.....	32
5.1.0.2.14	lim_stat_enab.....	32
5.1.1	Limit Table Configuration	33
5.1.1.0	aem_lim_tbl.....	33
5.1.1.0.1	free_lim_tbl	33
5.1.1.1	adc_lim	33
5.1.1.1.1	limit.....	33
5.1.1.1.2	persist.....	33
5.1.1.2	aem_lim_enab.....	33
5.1.1.2.1	free_lim_enab	33
5.2	Configuration File Utilities.....	34
5.2.0	File Validation	34
5.2.1	File Building	34
6	Commanding	35
6.0	Command Format.....	35

6.1	Command Types	35
6.1.0	Request Diagnostic Packet: Command	35
6.1.0.0	Request Diagnostic Packet: Parameters	35
6.1.1	Diagnostic Cancel: Command.....	36
6.1.2	System Reset: Command	36
6.1.2.0	System Reset: Parameters	36
6.1.3	No-Op: Command	36
7	Telemetry	37
7.0	1553 Service Callback.....	37
7.1	Packetization	37
7.2	Packet Descriptions.....	37
7.3	Diagnostic Packets	39
7.4	Packet Layout.....	40

Figures

Figure 1	Housekeeping Message and Data Flow	22
-----------------	--	----

Tables

Table 1	TEM Environmental Measurements	3
Table 2	TEM Conversion Constants.....	5
Table 3	PDU Environmental Quantities.....	6
Table 4	PDU Power Management.....	7
Table 5	AEM Environmental Quantities	8
Table 6	Free Board Power Status	9
Table 7	Low Rate Science Quantities	9
Table 8	EBM Statistics	10
Table 9	CPU Metrics	11
Table 10	Telecommand Counters	12
Table 11	Command Counter Tasks	12
Table 12	Task Messaging Configuration.....	13
Table 13	Messaging Configuration Tasks.....	13
Table 14	File System Statistics	15
Table 15	MEM Statistics	15
Table 16	1553 Remote Terminal Statistics	16
Table 17	LIM Statistics	17
Table 18	LTC Statistics	18
Table 19	LATC Statistics	19
Table 20	Summary of Housekeeping Data Set	20
Table 21	ADC Status Codes	25
Table 22	Acquisition Opcodes.....	30
Table 23	Real-Time Housekeeping Packets (by APID)	37
Table 24	Real-Time to Diagnostic APID Mapping.....	39

0 Introduction

The LAT housekeeping system accumulates, examines, and reports instrument health and status information. Monitor points consist of voltages, currents, and temperatures, as well as low rate science counters, processor metrics, and task statistics. The dataset is limit checked where appropriate and telemetered via 1553 CCSDS packets.

0.0 Overview

The housekeeping system is divided into several functional blocks operating throughout all major subsystems of the LAT. They consist of configuration, data collection, bounds checking with alarming, and telemetry reporting. The values are read from the instrument hardware registers and software interfaces on synchronous and asynchronous schedules. Time sliced scheduled execution ensures servicing of the 1553 remote terminal service requests, data acquisition cycles, and processing of ground originated telecommands. A subset of collected measurements are limit checked against thresholds contained in housekeeping specific configuration files residing on the LAT file system. These files also dictate the appropriate data collection schedule and packet delivery order. Housekeeping data is reported in 116-byte packets starting each telemetry frame sent by the LAT to the spacecraft. Commanded housekeeping data (“dwell” housekeeping) is transferred via the diagnostic channel to the 1553 data bus.

0.1 Definitions and Acronyms

TBD

0.2 Reference Documentation

1. LAT-TD-00605, "Tower Electronics Module - Programming ICD specification", by Michael Huffer
2. LAT-TD-01543, "Power Distribution Unit - Programming ICD specification", by Michael Huffer
3. LAT-TD-00639, "ACD Electronics Module - Programming ICD specification", by Michael Huffer
4. LAT-TD-01547, "Command/Response Unit - Programming ICD specification", by Michael Huffer
5. LAT-TD-01546, "Event Builder Module - Programming ICD specification", by Michael Huffer
6. LAT-TD-01545, "GLT Electronics Module - Programming ICD specification", by Michael Huffer
7. LAT-TD-00606, "LAT Inter-module Communications", by Michael Huffer
8. LAT Flight Software Document, "Telecommand and Telemetry Formats", by Dan Wood and Rich Morin (see "Telecommand and Telemetry Packets" heading on the FSW Web site: http://www.slac.stanford.edu/exp/glast/flight/web/FSW_home.shtml)
9. LAT Flight Software (Traveler) Document, "CTDB 1553 Drivers", by Dan Wood
10. "GLAST 1553 Bus Protocol Interface Control Document", Spectrum Astro, Inc.
11. LAT Flight Software (Traveler) Document "LHK Manual", (defunct)
12. LAT Flight Software (Traveler) Document "LIM Manual", by Don May
13. LAT Flight Software (Traveler) Document "LTC Manual", by Dan Wood
14. LAT Flight Software (Traveler) Document "LRA Manual", by Owen Saxton
15. LAT Flight Software (Traveler) Document "MEM Manual", by Don May
16. LAT Flight Software (Traveler) Document "FILE Manual", by Dan Wood

1 Health and Status Data

The housekeeping dataset consists of analog and digital values read directly from registers on the LAT hardware and information provided by active software subsystems. The values include environmental monitors, low-rate-science counts, communications statistics, CPU metrics, and task statistics.

1.0 Hardware Values

This section specifies the analog and digital values read directly from the LAT hardware.

1.0.0 Environmental Monitoring

Analog and digital environmental quantities for voltages, currents, and temperatures are provided by each TEM, each PDU (primary/redundant), and each AEM (primary/redundant). Most of the values are read from hardware registers fronting for 12 bit ADCs.

1.0.0.0 TEM Environmental Monitors

Each TEM provides 40 environmental monitor points for a total of 640 12 bit values. The measurements are comprised of voltages and currents for CAL and TKR Front-End power supplies, and temperatures for CAL AFEE boards and TKR cables. Table 1 lists the quantities collected for TEM environmental housekeeping.

Table 1 TEM Environmental Measurements

Name	Measurement	Quantity	Size (Bits)
TKR Digital 2.5V	Voltage	16	12
TKR Analog A 1.5V	Voltage	16	12
TKR Analog B 2.5V	Voltage	16	12
TKR Bias V0	Voltage	16	12
TKR Bias V1	Voltage	16	12
CAL Digital 3.3V	Voltage	16	12

CAL Analog 3.3V	Voltage	16	12
CAL Bias V0	Voltage	16	12
CAL Bias V1	Voltage	16	12
28 V0	Voltage	16	12
28 V1	Voltage	16	12
TEM Digital 3.3V	Voltage	16	12
AFEE ₀ T ₀	Temperature	16	12
AFEE ₀ T ₁	Temperature	16	12
AFEE ₁ T ₀	Temperature	16	12
AFEE ₁ T ₁	Temperature	16	12
AFEE ₂ T ₀	Temperature	16	12
AFEE ₂ T ₁	Temperature	16	12
AFEE ₃ T ₀	Temperature	16	12
AFEE ₃ T ₁	Temperature	16	12
TKR C ₀ , T ₀	Temperature	16	12
TKR C ₀ , T ₁	Temperature	16	12
TKR C ₁ , T ₀	Temperature	16	12
TKR C ₁ , T ₁	Temperature	16	12
TKR C ₂ , T ₀	Temperature	16	12
TKR C ₂ , T ₁	Temperature	16	12
TKR C ₃ , T ₀	Temperature	16	12
TKR C ₃ , T ₁	Temperature	16	12
TKR C ₄ , T ₀	Temperature	16	12
TKR C ₄ , T ₁	Temperature	16	12
TKR C ₅ , T ₀	Temperature	16	12
TKR C ₅ , T ₁	Temperature	16	12

TKR C ₆ , T ₀	Temperature	16	12
TKR C ₆ , T ₁	Temperature	16	12
TKR C ₇ , T ₀	Temperature	16	12
TKR C ₇ , T ₁	Temperature	16	12
Total		640	7680 (960 bytes)

See [1] for detailed information on TEM environmental register layout and access.

1.0.0.1 TEM Current Calculation

The tower, Tracker and Calorimeter currents are calculated by measuring the voltage before (V1) and after the sense resistor (V0), then subtracting V0 from V1 and dividing by the value of the sense resistor.

For the Tracker and Calorimeter, the value of the sense resistor is 5.1K. So currents are calculated as follows:

$$ITKR_{Bias} = (TKR \text{ Bias } V1 - TKR \text{ Bias } V0)/5.1K$$

$$ICAL_{Bias} = (CAL \text{ Bias } V1 - CAL \text{ Bias } V0)/5.1K$$

For the tower, the value of the sense resistor is 0.2. So currents are calculated as follows:

$$ITEM = (28 V1 - 28 V0)/0.2$$

Note that the tower current requires individual calibration as follows:

$$ICalib_{TEM} = m(ITEM) + n$$

Where the actual value of m and n are calculated per TEM on the basis of the actual current measurement of two different loads.

1.0.0.2 TEM Conversion Constants

Table 2 TEM Conversion Constants

Name	1 count =
TKR Digital 2.5V	$(2.5 \times 1.5)/4095$
TKR Analog A 1.5V	$(2.5 \times 1.255)/4095$
TKR Analog B 2.5V	$(2.5 \times 1.5)/4095$
TKR Bias V0	$(2.5 \times 101)/4095$
TKR Bias V1	$(2.5 \times 101)/4095$
CAL Digital 3.3V	$(2.5 \times 2)/4095$

CAL Analog 3.3V	(2.5 x 2)/4095
CAL Bias V0	(2.5 x 101)/4095
CAL Bias V1	(2.5 x 101)/4095
28 V0	(13.221 x 2.5)/4095
28 V1	(13.221 x 2.5)/4095
TEM Digital 3.3V	(2.5 x 2)/4095

For the temperatures, the following calculation is used:

calibrated value = $c_0 + c_1(\text{raw value} - \text{offset}) + c_2(\text{raw value} - \text{offset})^2 + c_3(\text{raw value} - \text{offset})^3$
 with the following values:

- $c_0 = -2.1529$
- $c_1 = 0.0176472$
- $c_2 = 0.00000228441$
- $c_3 = 0.000000004006271$
- offset = 2000

1.0.0.3 PDU Environmental Monitors

Each PDU provides 160 environmental measurements consisting of voltages, currents, and temperatures. All values are 12 bits in length.

- DC-DC voltages in 3 EPU crates and 16 tower power supplies
- Temperatures in 3 EPU crates and 16 tower power supplies
- Temperatures on each TEM printed circuit board
- Temperatures on LAT mechanical structures

Details on these quantities are provided in [2].

Table 3 PDU Environmental Quantities

Name	Measurement	Quantity	Size (Bits)
ACD composite shell	Temperature	2	12
Calorimeter Baseplate	Temperature	16	12
VCHP-DSHP Interface	Temperature	12	12
VCHP-XLHP Interface	Temperature	12	12

VCHP Reservoir Heaters	Temperature	12	12
TEM PCB	Temperature	16	12
TEM Digital (3.3)	Voltage	16	12
TEM Power Supply	Temperature	16	12
Radiator Antifreeze Heaters	Temperature	2	12
Radiators	Temperature	12	12
ACD PMT Rail	Temperature	4	12
ACD BEA-Grid Interface	Temperature	2	12
Grid-Radiator Interface	Temperature	4	12
EPU Digital (3.3/5 sum)	Voltage	3	12
EPU	Temperature	3	12
Total		264*	3168 (396 bytes)*

* Quantity shown is doubled to reflect primary and redundant units operating simultaneously.

See [2] for detailed information on PDU environmental register layout and access.

1.0.0.4 PDU Power Management

The PDU maintains registers for the EPU 28V power supply, EPU primary/redundant DC/DC converter, TEM 28V power supply, ACD 28V power supply, ACD primary/redundant DC/DC converter, and ACD primary/redundant power supply.

Table 4 PDU Power Management

Name	Measurement	Quantity	Size (Bits)
EPU 28V Power Switch	Switch state	3	1
EPU Primary/Redundant DC/DC Converter	Converter state	3	1
TEM 28V Power Switch	Switch state	16	1
ACD 28V Power Switch	Switch state	1	1
ACD Primary/Redundant Power Supply Selector	Switch selector	1	1
ACD Primary/Redundant	Converter state	1	1

DC/DC Converter			
Total		25	21

1.0.0.5 AEM Environmental Monitors

The AEM provides 4 analog quantities associated with each of its 12 FREE boards for a total of 48 measurements. All values are 12 bits in length.

- V_{DD}
- Temperature
- HV1
- HV2

The AEM also provides environmental values for the DAQ board. Again, these quantities are 12 bits in length.

- The sum of the digital (3.3) currents over all FREE boards
- The temperature of the DAQ board
- The sum of the high voltage (28V) currents measured over all FREE boards
- The digital (3.3) voltage of the DAQ board

See [3] for complete details on these quantities.

Table 5 AEM Environmental Quantities

Name	Measurement	Quantity	Size (Bits)
Free board V _{DD}	Voltage	12	12
Free board Temp	Temperature	12	12
Free board HV1	Voltage	12	12
Free board HV2	Voltage	12	12
Free board I	Current (sum)	1	12
DAQ temperature	Temperature	1	12
HV1	Voltage	1	12
DAQ board V	Voltage	1	12
Total per AEM		52	624 (78 bytes)

See [3] for detailed information on AEM environmental register layout and access.

1.0.0.6 AEM Free Board Power Management

The AEM maintains a register reporting the power state of each of its 12 free boards.

Table 6 Free Board Power Status

Name	Measurement	Quantity	Size (Bits)
AEM Free Board Power	Switch state	12	1

1.0.1 Low Rate Science

The GEM and EBM both provide a small set of low rate science counter statistics. For all counters, a 32 bit delta timestamp is included with the measurement to indicate the elapsed time between register reads.

1.0.1.0 GLT Electronics Module (GEM) Low Rate Science

Also known as trigger performance counters. All counters are saturating, with the exception of the GEM Livetime counter. The table below describes the quantities and associated sizes.

Table 7 Low Rate Science Quantities

Name	Additional Documentation	Type	Quantity	Size (Bits)
GEM Livetime	See [6]	Rollover Counter	1	25
GEM Dead-Zoned	See [6]	Saturating Counter	1	16
GEM Window Prescaled	See [6]	Saturating Counter	1	24
GEM Window Busy	See [6]	Saturating Counter	1	24
GEM Window Sent	See [6]	Saturating Counter	1	16
Total			5	105 (14 bytes)

See [6] for detailed information on GEM low-rate-science register description, layout and access.

1.0.1.0.1 Livetime

- A 25 bit livetime counter incremented in units of system clock-tics

1.0.1.0.2 Dead-Zoned

- 16 bit dead-zoned counter

1.0.1.0.3 Window Turns

- 24 bit prescaled counter
- 24 bit busy counter
- 16 bit sent counter

1.0.1.1 Event Builder Module (EBM) Statistics

The EBM maintains a set of registers used to count LATp event reception and transmission statistics. These values are sampled from a utility that nominally updates at 1 Hz. The subset of values are transmitted with a delta timestamp that represents the elapsed time between successive reads. Note that the counters tally LATp event packets moved through the event fabric, not actual physics events. Please refer to [14] for further information on the register acquisition software used to sample these values.

Table 8 EBM Statistics

Name	Additional Documentation	Type	Quantity	Size (Bits)
GEM Events Received	See [5]	Counter	1	16
AEM Events Received	See [5]	Counter	1	16
SIU0 Events Received	See [5]	Counter	1	16
SIU1 Events Received	See [5]	Counter	1	16
EPU0 Events Received	See [5]	Counter	1	16
EPU1 Events Received	See [5]	Counter	1	16
EPU2 Events Received	See [5]	Counter	1	16
SIU0 Events Sent	See [5]	Counter	1	16
SIU1 Events Sent	See [5]	Counter	1	16
EPU0 Events Sent	See [5]	Counter	1	16
EPU1 Events Sent	See [5]	Counter	1	16
EPU2 Events Sent	See [5]	Counter	1	16
SSR Events Sent	See [5]	Counter	1	16
Total			13	208 (26 bytes)

1.0.2 CPU Metrics

The CPU metrics block consists of CPU junction temperature, processor loading, and RAD750 error counters. Each metric is kept for the SIU and all EPU.

To support the FSW requirements specification, the SIU Programmable Interrupt Discrete (PID) registers are sampled and transmitted in telemetry.

Table 9 CPU Metrics

Name	Measurement	Quantity	Size (Bits)
CPU Junction Temperature	Temperature in degrees Celsius	4	16
CPU Avg Load/Sec	Percentage	4	32
CPU Avg Load/Min	Percentage	4	32
CPU Mimumum Load/Min	Percentage	4	32
CPU Maximum Load/Min	Percentage	4	32
RAD750 PCI Errors	Counter	4	16
RAD750 Correctable Memory Errors	Counter	4	16
RAD750 Uncorrectable Memory Errors	Counter	4	16
SC->LAT PID0	Register	1	1
SC->LAT PID1	Register	1	1
SC->LAT PID2	Register	1	1
Total		35	769 (97 bytes)

1.1 Software Metrics

This section specifies housekeeping values derived from the FSW subsystems.

1.1.0 Inter-task Communications (ITC) Statistics

1.1.0.0 Telecommand Counters

ITC provides access to task-level communications statistics. Housekeeping gathers and reports the following telecommand counters for each of the listed tasks:

- Telecommands sent counter: telecommands sent to FSW tasks.
- Telecommand dispatch failure counter: telecommands that failed task dispatch.
- Telecommand execution failure counter: telecommands failing task execution.
- Timestamp of last telecommand received

Table 10 Telecommand Counters

Name	Measurement	Quantity	Size (Bits)
Command timestamp	Time	11	64
Commands sent	Counter	11	32
Command dispatch failure	Counter	11	16
Command execution failure	Counter	11	16
Total		44	1408 (176 bytes)

Table 11 Command Counter Tasks

Task Name	Task Description
LCM	LAT Computer Manager
LFS	LAT File System
LHK_M	LAT Housekeeping Master
LIM	LAT Instrument Mode Control
LSM_M	LAT Spacecraft Messaging Master
LSW	LAT Software Watchdog
LCI	LAT Charge Injection
LMC	LAT Multiplexed Counters
LTC	LAT Thermal Control
LPA_M	LAT Physics Acquisition Master
LRA	LAT Register Access

1.1.0.1 Task Messaging Configuration

ITC provides access to task-level messaging configuration. Housekeeping gathers and reports the following configuration states for each of the listed tasks on the SIU and all EPUs:

Table 12 Task Messaging Configuration

Name	Measurement	Quantity	Size (Bits)
Task Defined	Status	38	38
Message Level	Status	38	76
Command Confirm Normal Execution	Status	38	76
Command Confirm Normal Forward	Status	38	76
Command Confirm Broadcast Execution	Status	38	76
Command Confirm Broadcast Forward	Status	38	76
Total		228	418 (53 bytes)

Table 13 Messaging Configuration Tasks

Task Name	Task Description	CPU(s)
LCM	LAT Computer Manager	SIU/EPU
LFS	LAT File System	SIU/EPU
LHK_M	LAT Housekeeping Master	SIU
LHK_S	LAT Housekeeping Slave	EPU
LIM	LAT Instrument Mode Control	SIU
LSM_M	LAT Spacecraft Messaging Master	SIU
LSM_S	LAT Spacecraft Messaging Slave	EPU
LSW	LAT Software Watchdog	SIU/EPU
LCI	LAT Charge Injection	SIU

LMC	LAT Multiplexed Counters	SIU
LTC	LAT Thermal Control	SIU
LPA_M	LAT Physics Acquisition Master	SIU
LPA_S	LAT Physics Acquisition Slave	EPU
LRA	LAT Register Access	SIU
GRB	LAT GRB Algorithm	SIU
CRX	CTDB Receive	SIU
CTX	CTDB Transmit	SIU
LTX	LCB Transmit	SIU/EPU
LRXR	LCB Receive Result	SIU/EPU
LRXE	LCB Receive Event	SIU/EPU
STX	SDI Transmit	SIU/EPU

1.1.1 File System (FILE) Statistics

The FSW file system operates on a single file at a time, using a state machine to control file loads, writes, reads, and other operations.

From the SIU and all EPUs, the following statistics on the activity of the onboard file system are gathered and reported:

- File Buffer Address: The base address of the file upload buffer.
- File ID Commit: The file ID value for committing the file data to storage.
- File Offset Current: The offset of the last valid data telecommand.
- File Packet Count: The number of valid data packets received for the current file upload.
- File Error Count: A count of the number of errors reported for the current file upload.
- File Error Code: The current file upload error indicator.
- File Size Commit: The file size in bytes to write for the commit.
- File Size Current: The number of data bytes received for the current file upload.
- File Size Total: The total size in bytes expected for the current file upload.
- File Upload State: The current file upload state.

Please refer to [16] for further details on these values

Table 14 File System Statistics

Name	Measurement	Quantity	Size (Bits)
File Buffer Address	Address	4	32
File ID Commit	File ID	4	32
File Offset Current	Address	4	32
File Packet Count	Counter	4	32
File Error Count	Counter	4	32
File Error Code	FILE Package Error Code	4	32
File Size Commit	File Size in Bytes	4	32
File Size Current	File Size in Bytes	4	32
File Size Total	File Size in Bytes	4	32
File Upload State	FILE Package Mnemonic for Current State	4	32
Total		40	1280 (160 bytes)

1.1.2 Memory System (MEM) Statistics

The LAT memory subsystem manager maintains a block of data reporting the state of any memory operations, including uploads and dumps. The following values are reported for the SIU and all EPU's. Refer to [15] for details on these values.

Table 15 MEM Statistics

Name	Quantity	Size (Bits)
Status of most recent MEM command	4	32
Function code of most recent MEM command	4	32
Status of most recent load action	4	32
Nonzero if load is active	4	32
Starting load address	4	32
Total number of bytes to load	4	32

Current load offset	4	32
Status of most recent dump action	4	32
Nonzero if dump is active	4	32
Starting dump address	4	32
Total number of bytes to dump	4	32
Current dump address	4	32
Function code for current dump	4	32
Transaction ID for current dump	4	32
Total	56	1792 (224 bytes)

1.1.3 1553 Remote Terminal (CTDB) Statistics

The 1553 remote terminal driver maintains a set of software statistics that contain counters and status codes. Please refer to [9] for further details on these values.

Table 16 1553 Remote Terminal Statistics

Name	Measurement	Description	Size (Bits)
Terminal Error Count	Counter	A count of the number of remote terminal errors	32
Device Interrupts	Counter	A count of the number of remote terminal device interrupts	32
Command Packets Received	Counter	A count of the number of command packets received by the remote terminal	32
Command Bytes Received	Counter	A count of the number of command packet bytes received by the remote terminal	32
Command Packets Transmitted	Counter	A count of the number of command packets transmitted by the remote terminal	32
Command Bytes Transmitted	Counter	A count of the number of command bytes transmitted by the remote terminal	32
Housekeeping Packets Transmitted	Counter	A count of the number of housekeeping packets transmitted by the remote terminal	32
Housekeeping Bytes	Counter	A count of the number of housekeeping bytes	32

Transmitted		transmitted by the remote terminal	
Telemetry Packets Transmitted	Counter	A count of the number of telemetry packets (not housekeeping) transmitted by the remote terminal	32
Telemetry Bytes Transmitted	Counter	A count of the number of telemetry bytes (not housekeeping) transmitted by the remote terminal	32
Total			320 (40 bytes)

1.1.4 LAT Instrument Mode Control (LIM) Statistics

A block of statistics is collected from the LIM task. These values represent a snapshot of the LIM diagnostic telemetry packet. Please refer to [12] for details on each item.

Table 17 LIM Statistics

Description	Size (Bits)
Most Recent LIM Action	16
Most Recent Action Status	32
Operating Mode	8
Virtual Mode	8
SAA Transit Status	8
LCI Task State	8
LDF Task State	8
LPA Task State	8
TOO Started Status	8
TOO Started Status	8
TOO Ready Status	8
ARR Repoint Request Pending Status	8
ARR GRB State	8
ARR Started Status	8
ARR Ready Status	8

TOO Seconds Remaining	32
ARR Seconds Remaining	32
GBM Primary Interrupt Allowed Status	8
GBM Redundant Interrupt Allowed Status	8
GBM Repoint Request Allowed Status	8
ACD High-Voltage Allowed Status	8
GBM Interrupt Disable Seconds Remaining	32
	280 (35 bytes)

1.1.5 LAT Thermal Control (LTC) Statistics

A block of statistics is collected from the LTC task. These values are a direct snapshot of the LTC diagnostic telemetry packets. Generally, each HP value is present for all 12 heat pipes. Please refer to [13] for further information on these values.

Table 18 LTC Statistics

Name	Quantity	Size (Bits)
HP selected RES input HP#	12	16
HP selected RES input sensor type	12	16
HP selected RIT input HP#	12	16
HP selected RIT input sensor type	12	16
HP RIT Sensor Status	12	16
HP Reservoir Sensor Status	12	8
Control mode for VCHP heater	12	16
LTC control mode	1	16
Current command for VCHP heater	12	16
LTC run mode	1	16
VCHP heater state	12	16

HP RIT temperature in degrees Celsius	12	16
HP reservoir temperature in degrees Celsius	12	16
HP Low limit for RIT sensor in degrees Celsius	12	16
HP High limit for RIT sensor in degrees Celsius	12	16
HP Low limit for reservoir sensor in degrees Celsius	12	16
HP High limit for reservoir sensor in degrees Celsius	12	16
HP deadband delta limit in degrees Celsius	12	16
Raw Sensor Status DSHP Primary	12	16
Raw Sensor ADC Counts DSHP Primary	12	16
Raw Sensor Status DSHP Redundant	12	16
Raw Sensor ADC Counts DSHP Redundant	12	16
Raw Sensor Status XLHP Primary	12	16
Raw Sensor ADC Counts XLHP Primary	12	16
Raw Sensor Status XLHP Redundant	12	16
Raw Sensor ADC Counts XLHP Redundant	12	16
Raw Sensor Status RES Primary	12	16
Raw Sensor ADC Counts RES Primary	12	16
Raw Sensor Status RES Redundant	12	16
Raw Sensor ADC Counts RES Redundant	12	16
Total	338	5312 (664 bytes)

1.1.6 LAT Configuration (LATC) Statistics

The following statistics are sampled for the LATC package

Table 19 LATC Statistics

Description	Size (Bits)
Cached LATC File ID	32

	32 (4 bytes)
--	---------------------

1.2 Summary

The table below summarizes the housekeeping data categories. The size values reflect the raw data and does not account for extra timestamps, packet spares, or bit/byte padding.

Table 20 Summary of Housekeeping Data Set

Category	Quantity	Size (bytes)
Environmental	993	1438
Low Rate Science	18	40
CPU Metrics	35	97
ITC Task Statistics	272	229
FILE Statistics	40	160
MEM Statistics	56	224
1553 Statistics	10	40
LIM Statistics	22	35
LTC Statistics	338	664
LATC Statistics	1	4
Total	1785	2931

2 Implementation

2.0 Overview

Housekeeping operation is maintained by separate tasks executing on multiple CPUs. A set of tasks running on the SIU perform critical actions like processing commands, and managing data collection, and packet formation. Slave tasks operating on the EPUs autonomously collect data and forward it to the SIU housekeeping task.

The housekeeping master performs the following duties:

- reads housekeeping specific configuration files from the LAT file base
- schedules and performs register reads
- processes data from EPUs
- stores and manages database of collected data
- performs limit checks on data and raises appropriate alarms
- services requests for commanded collections
- formats data to CCSDS telemetry packets
- outputs packets to 1553 data bus

The housekeeping slave tasks perform the following duties:

- gathers software and cpu metrics
- construct and deliver fully formed CCSDS packets to the housekeeping master task

2.1 Data Acquisition

Most housekeeping sensor data is acquired by writing a value to a configuration register, or the actual register, waiting a predetermined amount of time, and then reading it back. The time at which the register is written to, plus a predetermined or negligible wait period, is the time at which the actual measurement occurred.

Software metrics are gathered by calling public software interfaces exposed by the providing package.

2.1.0 Data Flow

The master task interacts with multiple processes executing on the SIU and EPU through the LCB service. 1553 data is exchanged directly between the master task and the 1553 service. Figure 1 outlines the flow of messages and data between the HSK master/slave tasks, the LAT hardware, and other subsystems.

The housekeeping system is responsible for delivering housekeeping packets to the bus controller (the Spacecraft) over the 1553 interface. The Spacecraft controls how these packets are transmitted to the ground as well as written to the housekeeping partition on the Solid State Recorder.

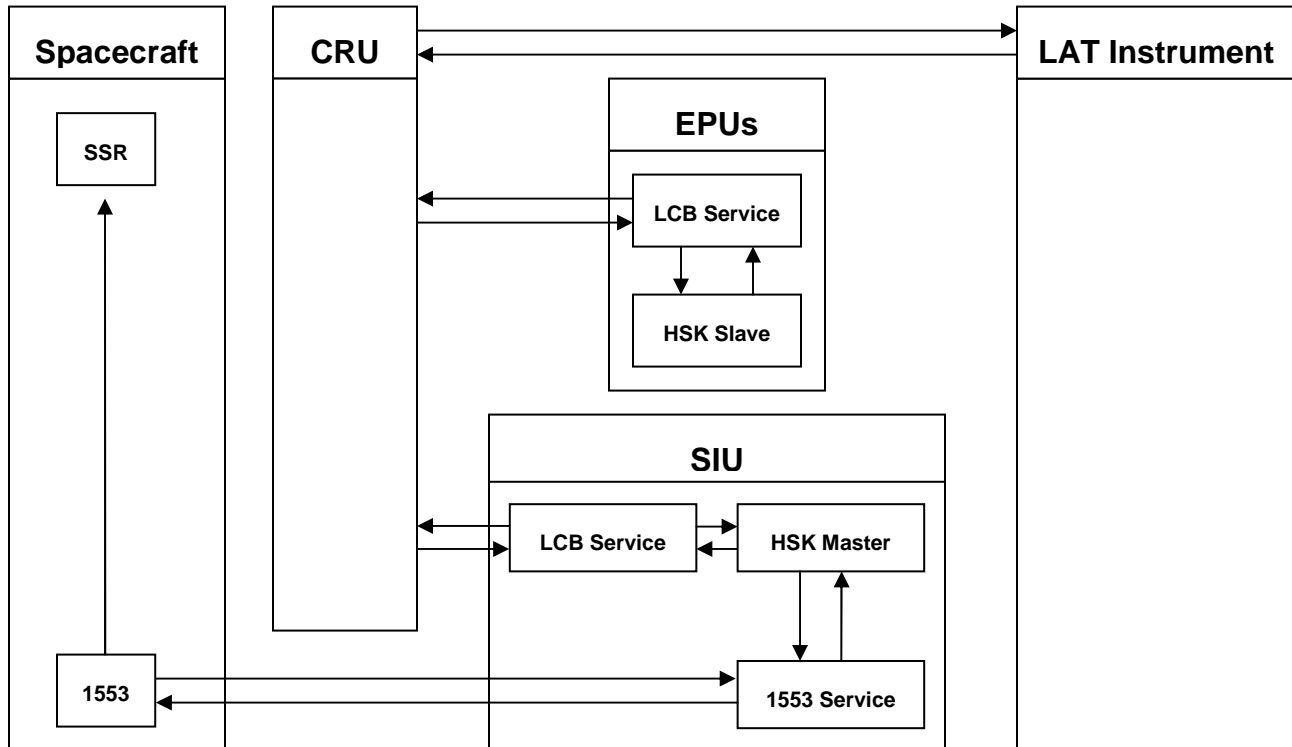

Figure 1 Housekeeping Message and Data Flow

2.2 Command Handler

The command handler task executes on the SIU and is responsible for intercepting telecommands, validating command parameters, receiving EPU telemetry messages, and queuing work messages to the scheduler task.

2.3 Scheduler

The scheduler executes on the SIU and consists of a single task and 2 wake-up timer mechanisms. The timers sole purpose is to schedule acquisition requests while the task processes responses and external requests.

The available actions for the scheduler wake up timer are:

- Submit a request for data from hardware
- Submit a request for data from software

The available actions for the diagnostic wake up timer are:

- Submit a request to generate a telemetry packet for delivery to the diagnostic stream

The available actions for the scheduler task are:

- Process asynchronous responses from hardware: validate and store data
- Process requests to acquire and store data from software interfaces
- Process request to store telemetry packets received from an EPU
- Process requests to construct and deliver a new packet to the 1553 housekeeping telemetry stream
- Process scheduler reconfiguration requests to rebuild acquisition and packet lists or update limit threshold values
- Process requests to construct and deliver a packet to the 1553 diagnostic telemetry stream

2.3.0 Schedule Execution

At initialization, or reconfiguration, two lists are constructed that describe what data points will be acquired, and what telemetry packets will be delivered. These are the acquisition and packet lists. These lists are constructed using static built-in defaults and dynamic configuration files.

2.3.0.0 Acquisition Schedule

The acquisition list consists of up to 32 items. The scheduler task uses a wake up timer to control execution of these acquisition items. When the wake up timer expires, the item at the head of the acquisition list is removed and processed.

For an asynchronous hardware transaction item, such as a TEM environmental register read, a request is submitted to the appropriate hardware using the LCB interface. This essentially queues a message to a hardware driver service task. A short time later, when the response is received from the hardware, a message is queued to the scheduler task, indicating the data is ready. The scheduler task will wake up, process the data, and replace the initiating item at the tail of the acquisition list.

For a synchronous software transaction item, the timer routine will queue the item to the scheduler task for direct execution. When the scheduler task gets the message from its queue, it calls the software interface routine, copies the data to storage, and replaces the item at the tail of the list.

By default, the acquisition wake up timer is set to expire at 50 millisecond intervals, or at a rate of 20Hz. This interval can be reconfigured to change the acquisition timing of the system. What this system essentially does is guarantee the *timing of acquisition requests* to either the hardware driver queue or the scheduler task queue. It is up to the scheduler task to validate, store, and deliver data *at the rate and in the order it is received*.

2.3.0.1 Housekeeping Packet Schedule

The packet list contains up to 64 apid values, each corresponding to a predefined telemetry packet. At 4Hz, the 1553 device driver calls a housekeeping interface routine which copies a full 116 byte packet for delivery to the housekeeping stream. At the completion of this data transfer, a request is queued to the scheduler task to prepare a new telemetry packet for delivery. When the scheduler receives this message, the packet corresponding to the next apid in the packet list is made ready for the next transfer. The packet list resets to the beginning upon encountering the final apid in the list.

2.3.0.2 Diagnostic Packet Schedule

The diagnostic wake up timer is initiated by a telecommand that contains an apid, packet count, and timer interval. At the requested interval, the timer issues a request to the scheduler task to construct and deliver the packet with the corresponding housekeeping apid to the diagnostic telemetry stream. The resulting diagnostic packet is identical in format to those delivered normally over the housekeeping stream. This diagnostic, or “dwell”, functionality allows a user to enjoy a faster data refresh rate than that nominally delivered in the 4Hz housekeeping stream.

Because EPU packets are delivered asynchronously and are not part of the normal scheduling process, they cannot be requested via diagnostic commands

2.4 EPU Slave Processing

The LHK slave task executes on an EPU and acquires a subset of measurements collected on the SIU:

- FILE statistics
- MEM statistics
- CPU loading and temperature
- RAD750 error counters

This task operates on a cycle defined in the LPA_DB CDM file. The task uses a wake up timer to periodically collect the above measurements, and construct a CCSDS telemetry packet for delivery to the SIU.

2.5 Limit Threshold Evaluation

A small subset of housekeeping data is evaluated using limiting thresholds specified in configuration files. Red limit violations (see below) are reported to the ground in the form of alert telemetry packets. Alert actions will occur if a value is out of limits for a predetermined amount of consecutive reads. Currently, FSW is only required to limit check AEM free board current values.

2.5.0 Status Codes/Alarm Categories

Each environmental ADC value is reported with a 4 bit status code. The following codes are valid for all ADC values:

Table 21 ADC Status Codes

Status	Code	Description	Action(s)
LHKSTATOK	0	Value within specified limits	None
LHKSTATUNDEF	1	Value was unreadable, therefore status is undefined	None
LHKSTATMSK	2	Value was masked for limit checks in configuration	None
LHKSTATRED	3	Value exceeded red limit	MSG Signal Alert Telemetry

2.5.1 Limit Table

The limit table is specified as a housekeeping specific configuration file. Certain environmental monitors use a single raw upper limit value, and a persistence count. Generation of the limit configuration file and other housekeeping configuration files is covered in the section on configuration files.

3 Package Description

This section describes the CMX package layout for LHK.

3.0 Shareables

The LHK package exports the following shareable libraries:

Module	Description
liblhk.o	The housekeeping master library
liblhk_cfg.o	The default housekeeping configuration data
liblhk_slv.o	The EPU slave library
liblhk_sim.o	The housekeeping master using an LCB simulation (test only)

3.1 Executables

- lhk_bswap - configuration file byte swap utility - (little endian architectures only)

3.2 Utilities

- lhk_config – accepts xml input file to produce configuration binaries

4 Programming

The LHK package provides several public control interfaces that are used to initialize, start, and stop the LHK system.

4.0 Initialization

LHK initialization routines take no parameters.

LHK_init()

LHK_init_slave()

4.1 Application Control

LHK_start() - launches the LHK master tasks

LHK_start_slv() - start the slave task

LHK_stop() - stop all LHK tasks

LHK_shutdown() - destroys all LHK structures and releases memory resources

5 Configuration

This section describes the process of configuration the LHK package. LHK is configured at initialization by reading in a CDM database file from the LAT file system, and by loading default parameters from an onboard library. Default parameters can be overridden by reconfiguring the system with data compiled from XML formatted files.

5.0 LHK_DB Files

The LHK_DB schema defines 3 parameters for application control:

sched_file_id – onboard file ID containing the scheduler configuration to be used at initialization

limit_file_id – onboard file ID containing the limit table configuration to be used at initialization

period – the EPU slave execution period in seconds

This CDM file should be loaded both on the SIU and EPUs.

5.1 XML File Types

LHK uses two primary configuration files. Each input xml file corresponds to one output binary:

- Schedule table values – contains the acquisition opcodes, apid sequences, and the acquisition schedule period. Contains schedule enabling mask values describing which values to collect.
- Limit table values - contains threshold values for limit checking and mask values describing which values to exclude from limit checking.

2 default XML files are provided in the /cfg directory of the LHK package.

5.1.0 Scheduler Table Configuration

The format of the scheduler configuration file consists of the follow tags:

```

<sched_cfg>
  <pkt_sched>
  <acq_sched>
  <sch_enab>
</sched_cfg>

```

5.1.0.0 pkt_sched

This tag defines the packet delivery schedule. 64 telemetry packet apid values are specified with the <apid> tag. All 64 values must be present, denoting empty slots with an apid of 0. A length value must be provided as an attribute to the pkt_sched tag specifying the count of non-zero apids. The valid range of apid values are 0x210 through 0x231.

```

<pkt_sched len='31'>
  <apid>0x210</apid>
  <apid>0x211</apid>
  ..
  <apid>0x000</apid>
</pkt_sched>

```

5.1.0.1 acq_sched

This tag defines the data acquisition schedule. The period of the scheduler is specified with the <period> tag. The lowest acceptable period is 32 milliseconds and the highest is 100 milliseconds.

The acquisition schedule is defined by a series of opcodes. Up to 32 opcodes can be specified using the <opcode> tag. An opcode of 0 denotes an empty slot. A length value must be provided as an attribute to the acq_sched tag specifying the count of non-zero opcodes.

```

<acq_sched len='8'>
  <period>0x32</period>
  <opcode>0x1</opcode>
  <opcode>0x2</opcode>
  ..
  <opcode>0x0</opcode>
</acq_sched>

```

Table 22 Acquisition Opcodes

Description	Opcode
Empty	0x0
TEM Environmental	0x1
AEM Environmental	0x2
PDU Environmental	0x3
PDU Power Status Registers	0x4
GEM Low-rate Science	0x5
FILE Statistics	0x6
ITC Communications Statistics	0x7
CPU Metrics	0x8
1553 RT Statistics	0x9
MEM Statistics	0xa
LTC Statistics	0xb
LIM Statistics	0xc
EBM Statistics	0xd

5.1.0.2 sched_enab

The scheduler enable file consists of the following tags:

```
<sch_enab>
  <tem_adc_enab id='0'>
  <tem_adc_enab id='1'>
  <tem_adc_enab id='2'>
  <tem_adc_enab id='3'>
  <tem_adc_enab id='4'>
  <tem_lrs_enab>
  <aem_adc_enab>
  <pdu_adc_enab>
  <pdu_reg_enab>
  <gem_lrs_enab>
  <ebm_stat_enab>
  <comm_stat_enab>
  <file_stat_enab>
  <cpu_met_enab>
  <rt_stat_enab>
  <mem_stat_enab>
  <ltc_stat_enab>
  <lim_stat_enab>
</sch_enab>
```

5.1.0.2.1 tem_adc_enab

This tag specifies a 16 bit mask describing which tems are enabled for acquisition of environmental data for a given mux channel. A value of 0xffff signifies enabling of all 16 tems. 5 tem_adc_enab tags are required to describe each mux channel. Each tag requires an id attribute to specify the mux channel id.

5.1.0.2.2 tem_lrs_enab

This tag specifies a 16 bit mask describing which tems are enabled for acquisition of low-rate science data. A value of 0xffff signifies enabling of all 16 tems.

5.1.0.2.3 aem_adc_enab

This tag specifies a 13 bit mask describing which aem free boards are enabled for acquisition of environmental data. A value of 0x1fff signifies enabling of all free boards.

While there are only 12 free boards, the 13th enable controls summary and DAQ board quantities which are read out as the 13th free board

5.1.0.2.4 pdu_adc_enable

This tag specifies a 16 bit mask describing which of the 8 pdu environmental groups are enabled for both pdu0 and pdu1. The top 8 bits are for pdu1 and the lower 8 bits are pdu0.

5.1.0.2.5 pdu_reg_enab

This tag specifies a 2 bit mask describing which of the two pdus are enabled for acquisition of the power status registers.

5.1.0.2.6 gem_lrs_enable

This tag specifies a 4 bit mask signifying the enable status of each of the GEM low-rate science counters.

- bit 0 - Livetime
- bit 1 - Prescaled
- bit 2 - Discarded
- bit 3 - Sent

5.1.0.2.7 **ebm_stat_enab**

This tag specifies a one bit enable status of the EBM statistics.

5.1.0.2.8 **comm_stat_enab**

This tag specifies a one bit enable status of the communication statistics read from ITC.

5.1.0.2.9 **file_stat_enab**

This tag specifies a 4 bit mask signifying the enable status of the file statistics for each cpu.

- bit 0 - SIU
- bit 1 - EPU0
- bit 2 - EPU1
- bit 3 - EPU2

5.1.0.2.10 **cpu_met_enab**

This tag specifies a 4 bit mask signifying the enable status of the cpu metrics for each cpu.

- bit 0 - SIU
- bit 1 - EPU0
- bit 2 - EPU1
- bit 3 - EPU2

5.1.0.2.11 **rt_stat_enab**

This tag specifies a 1 bit enable status of the 1553 remote terminal statistics.

5.1.0.2.12 **mem_stat_enab**

This tag specifies a one bit enable status of the MEM statistics.

5.1.0.2.13 **ltc_stat_enab**

This tag specifies a one bit enable status of the LTC statistics.

5.1.0.2.14 **lim_stat_enab**

This tag specifies a one bit enable status of the LIM statistics.

5.1.1 Limit Table Configuration

This file controls limit threshold values and the enabling of limit checking for environmental quantities in the AEM.

```

<lim_cfg>
  <aem_lim_tbl>
    <free_lim_tbl id='0'>
      <adc_lim id='0'>
        </limit>
      </persist>
    </adc_lim>
  </aem_lim_tbl>
  <aem_lim_enab>
    <free_lim_enable id='0'>
  </aem_lim_enab>
  ..
</lim_cfg>

```

5.1.1.0 aem_lim_tbl

This tag contains the environmental limit values for the aem.

5.1.1.0.1 free_lim_tbl

This tag contains the environmental limit values for a free board. 13 of these are required each with an id attribute to denote the free board id. Each free_lim_tbl tag contains 4 adc_lim tags

5.1.1.1 adc_lim

This tag contains the limit values for an adc. The id attribute denotes the adc id.

5.1.1.1.1 limit

The limit tag describes the threshold limit value in raw counts.

5.1.1.1.2 persist

The persist tag describes a persistence limit, or count of consecutive allowed limit violations before alert telemetry notification is issued.

5.1.1.2 aem_lim_enab

This tag contains the enable configuration for the aem environmental limits.

5.1.1.2.1 free_lim_enab

This tag describes a 4 bit mask for limit checking of the 4 adc values in a free board environmental block. 13 of these tags are required, each with an id attribute to denote the free board id.

While there are only 12 free boards, the 13th enable controls summary and DAQ board quantities which are read out as the 13th free board.

5.2 Configuration File Utilities

The LHK package provides a script for compiling configuration files. The script accepts a formatted xml file, and outputs a binary object, ready for upload to the instrument.

5.2.0 File Validation

After an xml configuration file has been altered, it can be checked for well-formedness and validity using the validating parser:

```
lhk_config validate <xml_file>
```

5.2.1 File Building

After an xml configuration file has been altered, it must be compiled to binary format. With an active CMX environment:

```
lhk_config build <xml_file>
--outfile=<output_filename>: specify the output filename (optional)
--hdr: attaches a default header (optional)
--keep: keeps intermediate files (optional)
```

The build script transforms the xml file to an intermediate source file, compiles to binary, and adds a file header using the facility provided by the FILE package.



The build script compiles the source files and adds a file header using the facility provided by the FILE package. Consequently, an active CMX session is required for building configuration files.

6 Commanding

A user can issue a telecommand to modify the behavior of the housekeeping system or to request collection of specialized housekeeping data set. The format of these commands and their applications are described in the following sections.

6.0 Command Format

Housekeeping telecommand formats will adhere to the CCSDS standard. Command parameters or function codes allow for the specification of actions to be taken by the housekeeping system. See [8] and [10] for detailed information on LAT-related commanding and CCSDS formatting.

6.1 Command Types

The housekeeping system supports four commands: (1) a command used to request that a specified number of housekeeping packets of a specified type be sent to the ground through the diagnostic telemetry stream, (2) a command to reset the housekeeping system and restart after re-reading the current configuration files or reading a new set of configuration files, (3) a stop command that cancels the current diagnostic stream of housekeeping data, and (4) a no-op command.

6.1.0 Request Diagnostic Packet: Command

This command requests that a number (count) of housekeeping packets with a specified APID be sent with a defined interval between packets. The contents of the packets will be formatted exactly the same as the real-time counterparts.

6.1.0.0 Request Diagnostic Packet: Parameters

count - count of diagnostic packets to send. The maximum value is 64.

apid - LHK telemetry apid to send. The valid range is 0x210 through 0x22b.

interval - minimum of 100 milliseconds, maximum of 4000 milliseconds

6.1.1 Diagnostic Cancel: Command

This command cancels any active diagnostic that housekeeping is executing. This command accepts no parameters.

6.1.2 System Reset: Command

This command resets the housekeeping system and passes the ID of up to 4 housekeeping configuration files to be read upon re-initialization. If all zeroes are passed in, LHK will load the built-in default configuration.

6.1.2.0 System Reset: Parameters

file0 - a valid file ID or 0 for NULL

file1 - a valid file ID or 0 for NULL

6.1.3 No-Op: Command

This command takes no parameters and if received will elicit a success response. The purpose of this command is to verify task communications without taking any action.

7 Telemetry

Once data has been collected, it must be formatted into CCSDS packets for 1553 transmission. As configured by the user, housekeeping data can be selected for inclusion in the real-time housekeeping telemetry packet, the first 116 bytes of every LAT telemetry frame.

7.0 1553 Service Callback

The 1553 service requires that a housekeeping callback function be registered in order to guarantee population of the first 116 bytes of each telemetry frame. This callback is executed at 4Hz by the 1553 remote terminal service. The 1553 service is in charge of requesting one housekeeping telemetry packet for every telemetry block. The housekeeping callback function is passed a pointer to the reserved 1553 packet buffer and must copy a new formatted packet to that location

See [9] for detailed information on the 1553 driver implementation and housekeeping callback service.

7.1 Packetization

Real-time housekeeping data must be formatted to fit into packets of exactly 116 bytes. To ensure self-contained datasets, information does not span multiple packets. Data can be grouped to conserve size and maximize bandwidth usage. *See [9] for further information on packet headers and APIDs.*

7.2 Packet Descriptions

Listed below are the real-time housekeeping packets. These packets are delivered using the mechanism described in section 5.0.

Table 23 Real-Time Housekeeping Packets (by APID)

Name	APID	Description
TemEnvPwr0	0x210	Power specific values for TEM 0,1,2
TemEnvPwr1	0x211	Power specific values for TEM 3,4,5

Name	APID	Description
TemEnvPwr2	0x212	Power specific values for TEM 6,7,8
TemEnvPwr3	0x213	Power specific values for TEM 9,a,b
TemEnvPwr4	0x214	Power specific values for TEM c,d,e
TemEnvPwr5	0x215	Power specific values for TEM f
TemEnvTemp0	0x216	Temperature specific values for TEM 0, 1
TemEnvTemp1	0x217	Temperature specific values for TEM 2, 3
TemEnvTemp2	0x218	Temperature specific values for TEM 4, 5
TemEnvTemp3	0x219	Temperature specific values for TEM 6, 7
TemEnvTemp4	0x21a	Temperature specific values for TEM 8, 9
TemEnvTemp5	0x21b	Temperature specific values for TEM a, b
TemEnvTemp6	0x21c	Temperature specific values for TEM c, d
TemEnvTemp7	0x21d	Temperature specific values for TEM e, f
PduEnv0	0x21e	PDU0 environmental quantities
PduEnv1	0x21f	PDU0 environmental quantities
PduEnv2	0x220	PDU0 environmental quantities
PduEnv3	0x221	PDU0 environmental quantities
PduEnv4	0x222	PDU1 environmental quantities
PduEnv5	0x223	PDU1 environmental quantities
PduEnv6	0x224	PDU1 environmental quantities
PduEnv7	0x225	PDU1 environmental quantities
AemEnv0	0x226	AEM free board environmental quantities
Lrs0	0x227	Low-rate science values
CmdCnt0	0x228	Telecommand counter values
CmdCnt1	0x229	Telecommand counter values
SiuStats	0x22a	File, MEM, and CPU Metrics for the SIU

Name	APID	Description
Epu0Stats	0x22b	File, MEM, and CPU Metrics for EPU0
Epu1Stats	0x22c	File, MEM, and CPU Metrics for EPU1
Epu2Stats	0x22d	File, MEM, and CPU Metrics for EPU2
LTCData0	0x22e	LAT Thermal Control Data Packet 0
LTCData1	0x22f	LAT Thermal Control Data Packet 1
LTCData2	0x230	LAT Thermal Control Data Packet 2
LTCData3	0x231	LAT Thermal Control Data Packet 3
ItcCfg	0x232	ITC Task Configuration Packet

7.3 Diagnostic Packets

The housekeeping diagnostic packet structure is identical to that of the real-time packets. Below is the mapping table for diagnostic to real-time packets.

EPU packets cannot be requested via diagnostic commands

Table 24 Real-Time to Diagnostic APID Mapping

Diagnostic APID	Real-time APID
0x270	0x210
0x271	0x211
0x272	0x212
0x273	0x213
0x274	0x214
0x275	0x215
0x276	0x216
0x277	0x217
0x278	0x218
0x279	0x219
0x27a	0x21a

Diagnostic APID	Real-time APID
0x27b	0x21b
0x27c	0x21c
0x27d	0x21d
0x27e	0x21e
0x27f	0x21f
0x280	0x220
0x281	0x221
0x282	0x222
0x283	0x223
0x284	0x224
0x285	0x225
0x286	0x226
0x287	0x227
0x288	0x228
0x289	0x229
0x28a	0x22a
0x28e	0x22e
0x28f	0x22f
0x290	0x230
0x291	0x231
0x292	0x232

7.4 Packet Layout

The structure and contents of the real-time housekeeping and housekeeping diagnostic packets are published in HTML and PDF format on the FSW Website (see [8]). The tools and process for defining the contents of these packets are described in the file configuration section.

Generally speaking, packets issued by the housekeeping system contain CCSDS protocol (e.g., header fields), fields containing the data described in Section 1, and spare bit and byte fields used to pad packets.