

GLAST Large Area Telescope Instrument Science Operations Center

Science Operations Update

Eduardo do Couto e Silva & Seth Digel (SLAC)

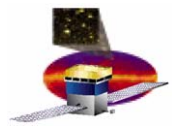

Outline

- ❑ **Brief overview and status of Science Operations**
 - **Operations** (shifts, coordination with Flight Operations)
 - **Data processing:** Level 1 (reconstruction and classification) and some Level 2 (time-critical science and routine processing)
 - **Calibration & Configuration** (analysis and management)
 - **Monitoring** (data, LAT performance) **and data analysis**
- ❑ **Operations Simulation 1**
- ❑ **Summary**

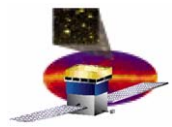

Operations

- ❑ **Daily operations will be via Shift Coordinators and Duty Scientists**
 - Participation from across the collaboration
 - This work is envisioned to be at SLAC for the first 6 months of the mission – to be revisited at that time [moving toward automation]
 - Roles and procedures are being refined in preparation for the **Operations Simulation** in October (more later)
- ❑ **Duties of the Shift Coordinator**
 - For high priority problems, initiating contingency procedures in coordination with LAT Commissioner and ISOC managers
 - Interfacing with Flight Operations (e.g., mission planning, contingency, changes in configurations and calibrations)
 - And interfacing with LAT science groups – transient science (e.g., GRB/flare advocates)
 - CCBs, meetings, reports...
 - And, well, coordinating shifts and on-call experts

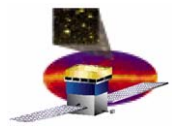

Operations (2)

❑ Duties of the Duty Scientist

- Monitoring housekeeping telemetry points relevant to SO (e.g., rates, SSR fill up “counters”)
- Mission Planning – being knowledgeable of the current timeline
- Identifying problems in monitoring, data transfer and data processing displays/tables/reports/
- Diagnosing, classifying, and documenting (via JIRA) problems
 - On-call experts: e.g., ACD, CAL,TKR, DAQ, trigger, pipeline, reconstruction, ASP

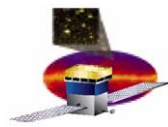

SO Operations Support Requirements (L&EO)

- ❑ **LAT Commissioner, J. E. Grove (NRL) often @ MOC**
- ❑ **Shift coordinators**
 - **1-2 at SLAC at any time, will ask for commitment for full L&EO term (2 mos)**
- ❑ **Duty scientists**
 - **3-4 at SLAC at any time (~2-week terms)**
- ❑ **On-call experts**

- ❑ **These positions will rotate among the LAT Collaborators**
- ❑ **Roles will evolve after learning through rehearsals prior to launch**
 - **We will revisit roles after commissioning on-orbit**

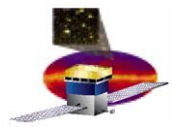

Data Processing

❑ Simplified data flow diagram

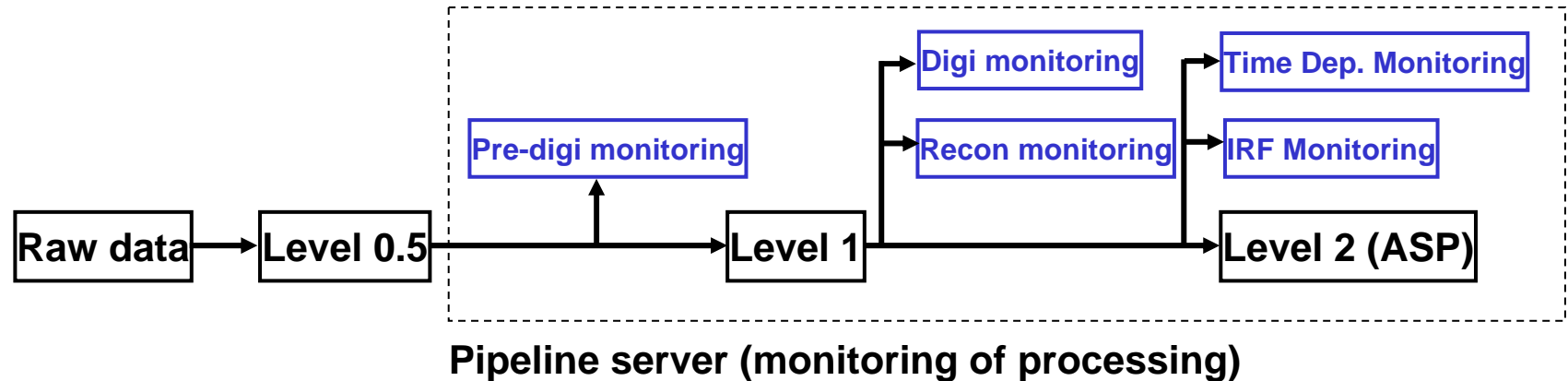

- ❑ The pipeline server itself and the L0.5 and L1 pipelines have been a core development task at SLAC
- ❑ L1 processing is more than reconstruction and classification of events
 - **Position/attitude/livetime history (ASI/INAF)**
- ❑ Monitoring and automated analyses are being added to L1 and L2 with contributions from the LAT collaboration (more later)

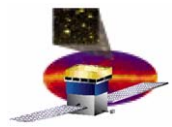

Data Processing: Automated Science Processing

- ❑ ASP is triggered by the availability of L1 data and for some tasks by external events (e.g., GRB alerts from other instruments)
- ❑ The pipeline task for source monitoring has been implemented and tested with DC2 data (INFN/Perugia, SLAC)
 - GCN ‘alerts’ devised for blazars
 - The database system for managing the list of monitored sources and the continually-updated light curves is in development
- ❑ An algorithm for detecting flaring sources (not otherwise being monitored) has been demonstrated and is being implemented as a pipeline task (INFN/Perugia, ASI/INAF, SLAC)

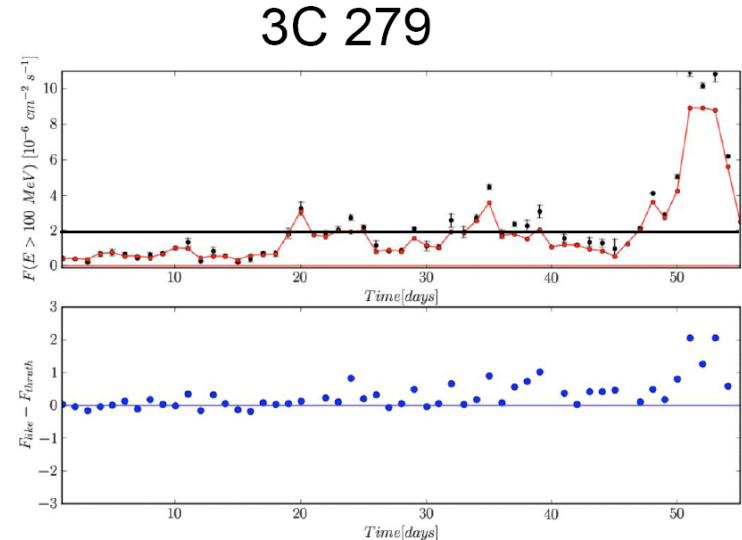

Declaration Type	Index	Item Name	Units	Comments
long	0	pkt_type	integer	Packet type number (=???)
long	1	pkt_sernum	integer	1 thru infinity
long	2	pkt_hop_cnt	integer	Incremented by each node
long	3	pkt_sod	[centi-sec]	(int)(sssss.sss *100) (SOD = second-of-day)
long	4	trig_num	integer	Trigger number (number of 0.1 secs since 01Jan2001)
long	5	trig_tjd	[days]	Truncated Julian Day
long	6	trig_sod	[centi-sec]	(int)(sssss.sss *100) (UT second-of-day)
long	7	agn_ra	[0.0001-deg]	(int)(0.0 to 359.9999 *10000) (LAT Coordinates / Catalog Coord)
long	8	agn_dec	[0.0001-deg]	(int)(-90.0 to +90.0 *10000) (LAT coordinate / Catalog Coord)
long	9	agn_name	[integer]	LAT catalog name / AGN Catalog name
long	10	agn_cnts	[cnts/s]	Evt_cnts in ??? energy bands
long	11	agn_pos_error	[0.0001-deg]	(int)(0.0 to 180.0 *10000)
long	7-15	spare[9]	integer	40 bytes for the future
long	16	lon_lat	2_shorts	(int)(Longitude, Latitude *100)
long	17-19	misc	bits	Misc stuff packed in here -> (known source, etc.)
long	20	spare	integer	4 bytes for the future
char	22-38	url	-	The URL for the lightcurve
long	39	pkt_term	integer	Pkt Termination (always = \n)

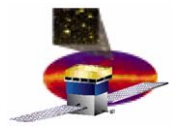

Data Processing: ASP (2)

- GRB handling/testing is well advanced in ASP (INFN/Pisa, SLAC)
 - Routine searches for untriggered GRBs (tested on new 55-day interleave simulation)
 - GRB refinement and afterglow searches are also implemented as pipeline tasks
 - GCN notices are also generated with the standard contents

3 GRBs found here (some spurious triggers owing to artifacts from SAA handling in the simulation)

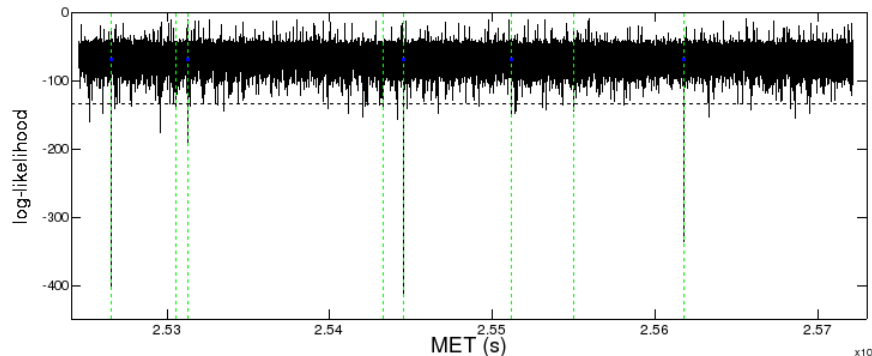

```

TITLE: GCN/GLAST NOTICE
NOTICE_DATE: Fri Jul 27 11:06:14 2007
NOTICE_TYPE: GLAST-LAT GRB Trigger
TRIGGER_NUM: 127709433, Sequence_Num: 0
GRB_RA: 275.831d {+18h 20m 07s} (J2000),
274.381d {+18h 17m 12s} (B1950)
GRB_DEC: -17.963d {-17d 57' 45"} (J2000),
-17.985d {-17d 59' 06"} (B1950)
GRB_ERROR: 10.00 [arcmin radius, statistical only]
GRB_INTEN1: 20 [0.0 < cnts < 0.1 (GeV)]
GRB_INTEN2: 5 [0.1 < cnts < 1.0 (GeV)]
GRB_INTEN3: 1 [1.0 < cnts < 10. (GeV)]
GRB_INTEN4: 0 [10. < cnts (GeV)]
GRB_DATE: 13388 TJD; 18 DOY; 5.0/1.0/18.0
GRB_TIME: 10233.93 SOD {02:50:33.00} UT (trigger time)
TRIGGER_DUR: 3.468 [sec] (interval, Tlast-Tfirst photons)
TRIGGER_INDEX: 1 (precise definition TBD)
TRIGGER_SIGNIF: 12.1 [sigma] (precise definition TBD)
GRB_PHI: 90.00 [deg]
GRB_THETA: 4.54 [deg]
SUN_POSTN: 12.56d {+00h 59m 14s} +5.38d {+05d 23' 01"}
SUN_DIST: 89.39 [deg] Sun_angle= 6.0 [hr] (West of Sun)
MOON_POSTN: 79.78d {+05h 19m 07s} +28.27d {+28d 15' 60"}
MOON_DIST: 137.38 [deg]
MOON_LLLUM: 31 [N]
GAL_COORDS: 40.11, 4.28 [deg] galactic lon,lat of the burst (or transient)
ECL_COORDS: 284.27, 31.16 [deg] ecliptic lon,lat of the burst (or transient)
COMMENT: ~/nfs/farm/g/glast/u26/MC-tasks/CreateFits_Interleave55days/output_PtSCzenth_00/000274/MeritTuple_255409201_25542
  
```

- Solar flares may also become an ASP processing task (INFN/Trieste, SLAC)
 - The direction and time of a solar flare will not be a surprise but at least ASP must be aware of distinguishing between solar flares and GRBs

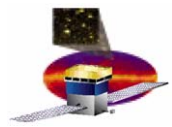

Calibrations and Configuration

- ❑ A configuration management tool has been implemented (**SLAC**)
 - Reduces the person time to generate and name new configurations (LATC XML file) to minutes from many hours
- ❑ Procedures for calibrating CAL high-energy scales are under development
 - Using heavy cosmic rays (**NRL, IN2P3/CENBG, Montpellier**)
 - Beam test may provide initial data point
- ❑ A calibration trending service (**SLAC**) is now available and being populated

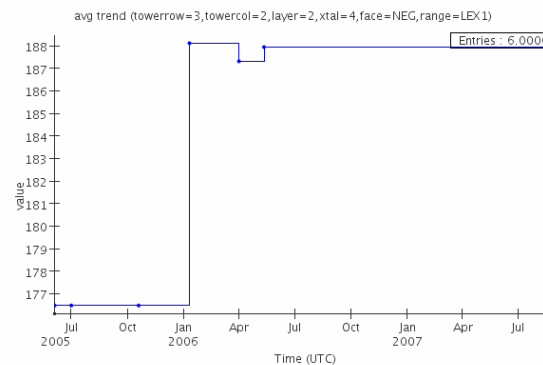
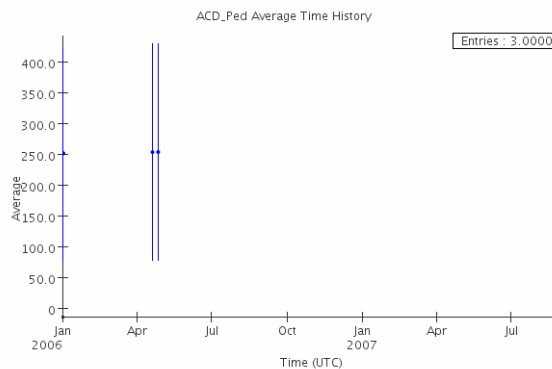

Examples of ACD & CAL pedestals from calibrations with ground testing data

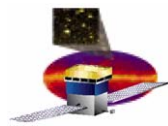

Calibrations and Configuration (2)

- Trade-off studies to identify when changes are needed for calibrations, configurations (e.g. trigger and data masks) have started – much more to study
 - ACD failure mode studies (INFN/Bari)

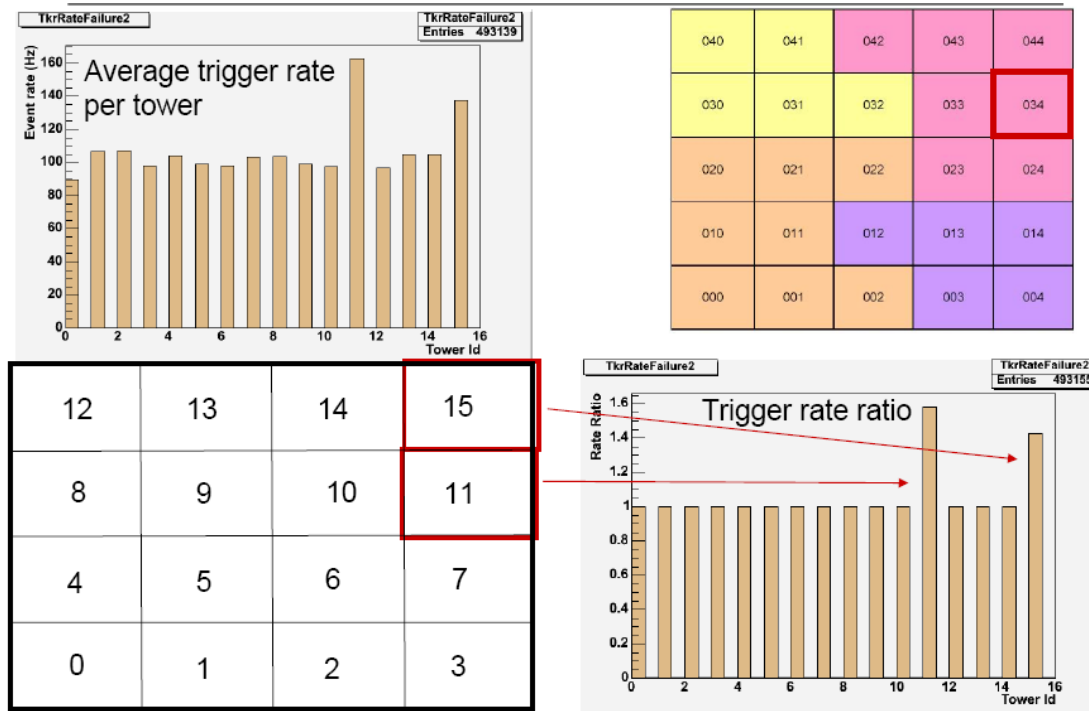

Example of the effect on trigger rates from failure of a top tile in the ACD – 2 towers are partially shadowed by the tile

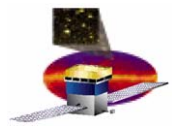

Monitoring: Data Quality

- For the most recent observatory test (ETE2), many monitoring tasks were integrated into the L1 pipeline and trending/plotting systems for the first time
 - Monitoring tasks included: Fast (pre-digi) data quality (INFN/Pisa), Time-dependent and end-of-run Digi and Recon (Pisa/SLAC)
 - These were tested with data recorded with the LAT (ETE2.1)

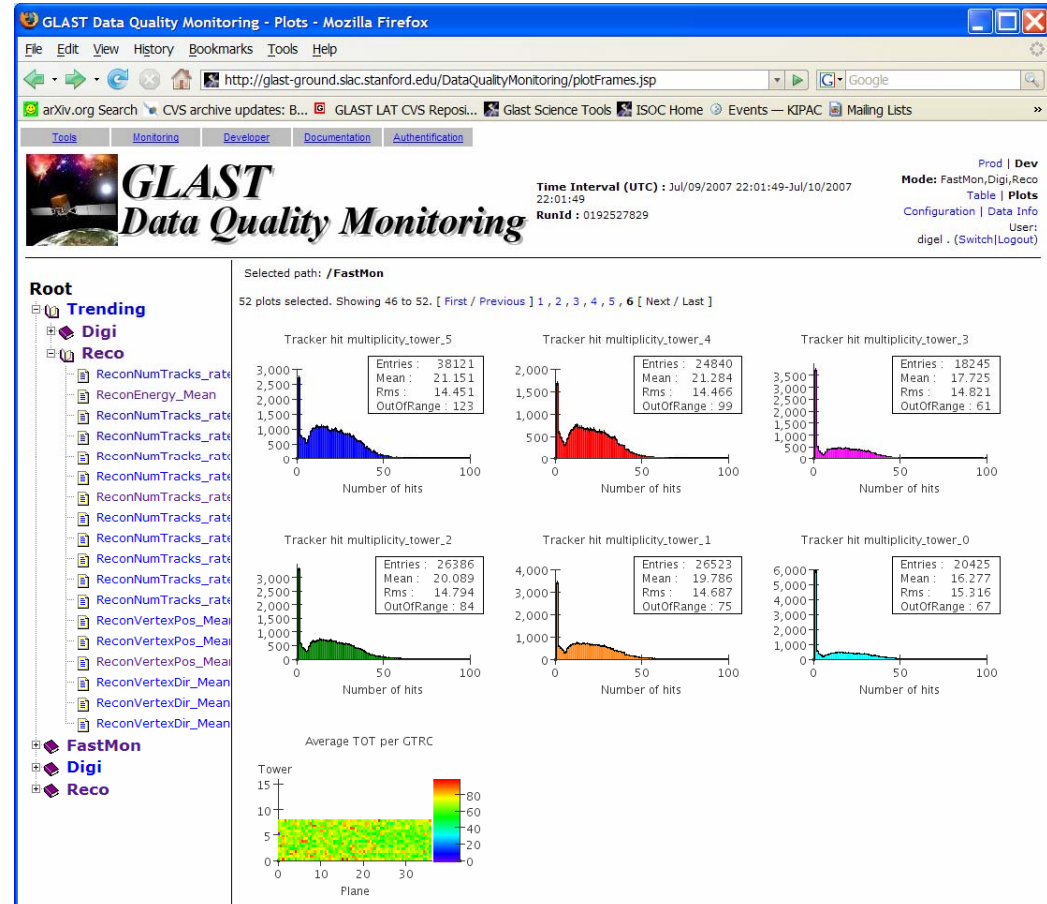

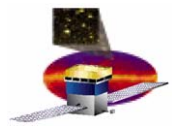

Monitoring: High-Level Performance

- ❑ Monitor PSF, Effective Area, and Energy Dispersion
 - Using the bright pulsars
 - Algorithms for each of these have been demonstrated (INFN/Perugia/Padova, IN2P3/CENBG) and they are being implemented as pipeline tasks
- ❑ Timing and position monitoring using pulsars has also been implemented for the pipeline (IN2P3/CENBG)

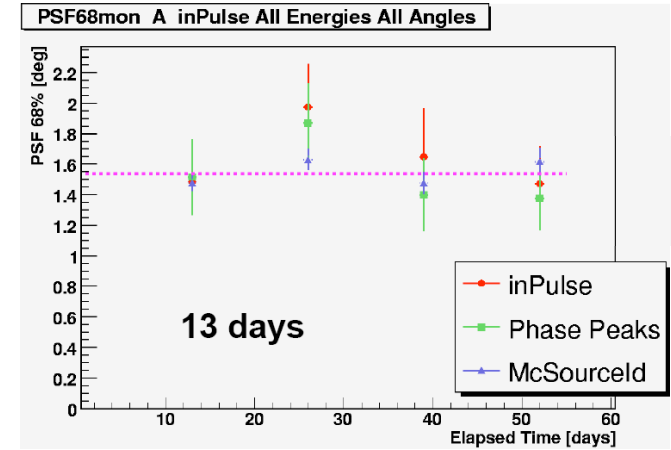

Uncertainty in 68% PSF diameter for Vela pulsar (with and without phase selection); dotted line is 55-day average

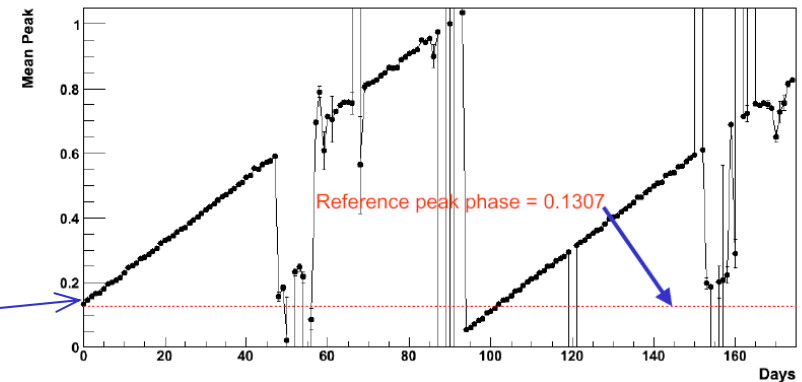
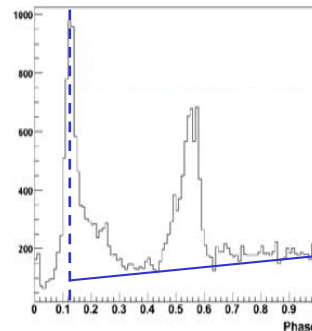

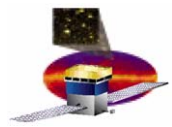

Data Analysis

- ❑ These analyses will not be automated, and potentially relate to the data at any level
- ❑ Some important examples we know and anticipate needing for L&EO in coordination with the C&A group, e.g.,
 - LAT alignment: internal (INFN/Pisa) and with respect to spacecraft (UW, SLAC)
 - Detector timing-in: internal timing for LAT data acquisition (SLAC and Subsystem teams)
- ❑ Unanticipated analyses – contingencies – undoubtedly will be needed
 - We are working to facilitate them, e.g., with the routine generation of monitoring plots and tables
 - A general system for reporting problems (out of limits) with the monitoring tasks is being implemented (INFN/Pisa)

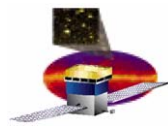

Operations Rehearsal: Ops Simulation 1

- 'Oktoberfest': 8-12 October, SLAC
 - A rehearsal of a large subset of L&EO activities for the LAT: infrastructure, processes, monitoring, trending, and analysis plus LAT command planning
 - Not part of the ground-system tests (ETE, DitL, MPE, ...)
- Driven by a day's worth (16 orbits) of detailed simulated data
 - Extensive updates have been implemented in the simulation, e.g., in terms of calculating the flags from the on-board filter, implementing 4-range readout, and producing L0 data
 - Need help with validation and analysis (Ops Sim and beyond)

Planned Ops Sim 1 Runs

Orbit #	Description	Obs Mode
1	initial configuration with conservative thresholds	sky-survey
2	nominal pre-launch configuration and a misconfigured CAL threshold	sky-survey
3	nominal pre-launch configuration with correct thresholds	sky-survey
4	high background rates and nominal pre-launch configuration	sky-survey
5	first nominal on-orbit configuration with tolerable rates	sky-survey
6	thresholds determination on-orbit (CAL and ACD together) Low setting	sky-survey
7	thresholds determination on-orbit (CAL and ACD together) Nominal setting	sky-survey
8	thresholds determination on-orbit (CAL and ACD together) High setting	sky-survey
9	first nominal on-orbit configuration with calibrated thresholds	sky-survey
10-11	Subtle problem related to instrument configuration (to be discovered by people on shift)	sky-survey
12	final nominal configuration on-orbit	sky-survey
13-16	final nominal configuration, Vela and a bright GRB burst	pointed obs

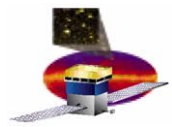

Operations Simulation 1 (2)

- ❑ Practice roles and responsibilities of **(recruitment and training)**
 - Shift Coordinator
 - Duty Scientist
 - Science Operations interfaces with
 - Flight Operations (e.g., mission planning, contingency, changes in configurations and calibrations)
 - LAT Science Groups (e.g., GRB/flare advocates)
- ❑ Demonstrate readiness of the infrastructure used for:
 - Transferring data
 - Processing data
 - Accessing data
 - Monitoring data and data processing
- ❑ The timing and scope of Operations Simulation 2 will depend on the outcome (lessons learned) of Ops Sim 1 and the needs of the Launch & Early Orbit studies

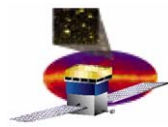

Launch & Early Orbit Studies

- ❑ L&EO planning (led by J. E. Grove/**NRL**, LAT Commissioner)
- ❑ Includes defining the detailed timeline from LAT power-up (**L+10d**) through the transition to routine science observations (**L+60d**)
- ❑ Most steps in the timeline have detailed, and time critical, analyses/calibrations to be planned; the major ones:
 - Filter Performance (**OSU**)
 - Detector Calibration Sequence (**Subsystems**)
 - SAA Boundary (**SLAC, Hiroshima**)
 - Detector Timing-In (**SLAC**)
 - Background Observation (**UCSC, Hiroshima**)
 - First Pointed Observation (**IN2P3/CENBG, GSFC, SLAC**)
 - Sky Survey Tuning (**GSFC, SLAC**)
 - LAT Alert Handling (**INFN/Pisa, SLAC**)

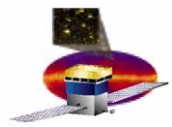

Summary

- ❑ The advances since March have (necessarily) been marked – concepts have rapidly become working prototypes
 - Vital contributions are coming from across the collaboration
- ❑ Operations Simulation 1 (Oct. 8-12) will be a close to real-life test of SO functions
- ❑ With the infrastructure/processing/monitoring tasks coming into place, the focus will shift to planning, and testing, analyses **and operations**
 - Continued support for Science Operations activities is important

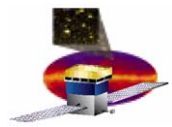

Backup slides



Duty Scientist and Burst Advocate

❑ ISOC Duty Scientist duties

- **Verify that a GCN notice was sent from GBM or other missions**
 - and displayed in the ISOC control room pages,
- **Ensure GRB group members were paged**
 - SMS messages worldwide to names in the GRB group
- **Ensure ISOC pages are populated with automated ASP data**
 - Monitor pipeline processes involved with GRB
- **Check the quality of the GRB/ASP data (coarse features)**
 - Document (with an ISOC report?) that GRB was inspected and data processed with no major problems in the GRB products

❑ GRB Advocate duties

- **Acknowledge receipt of SMS message with GRB alert**
 - Contact ISOC if more information is needed
- **Check the quality of the GRB/ASP data (in detail)**
 - Define and document (report) and was done and if it is a real burst
- **Perform manual analysis on the burst (joint if GBM is involved)**
 - Produce a report
- **Organize a meeting if necessary**
- **Create GCN notice and/or circular if applicable**
 - Manual procedures
- **Populate same web page pages with additional plots, reports, tables...**
 - Inform ISOC and analysis Coordinator that GRB has been thoroughly inspected

Operations: Proposal being Reviewed

- ❑ Prepare for 24/7 coverage @ SLAC for the first 6 months
 - Commissioning Phase : 60 days
 - Transition Phase: 120 days
 - will reassess at least twice whether 24/7 coverage is needed
- ❑ Roles
 - Shift Coordinator
 - resident at SLAC (rotate every 6 months)
 - » will consider shorter assignments after initial 6 months if operations are smooth enough
 - appointed at least 6 months in advance to allow training and smooth transition
 - Duty Scientist
 - resident at SLAC (rotating every 2 weeks)
 - consider coverage outside SLAC after reassessment early 2008
 - » to be discussed: frequency of shifts per institution and training of people
 - current questions: how long should shifts be and ‘overhead’ per run or downlink
- ❑ Automate tasks
 - Minimize routine work to be performed by Science Operations crew
 - rely on computer generated alerts/messages
- ❑ Conservative attitude toward changes in the instrument configuration
 - We are in space...don't touch if it is working
- ❑ Routine coordination meetings
 - SciOps and LAT Collaboration
 - Fridays, VRVS
 - SciOps, ISOC, GSSC, GBM, MOC
 - Tuesday Weekly timeline planning (timeline)
 - FlightOps and MOC
 - Daily tag ups 6 am PDT
 - SciOps invited but not required

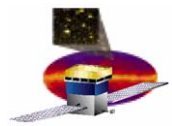

Sci Ops Anomaly Response Process

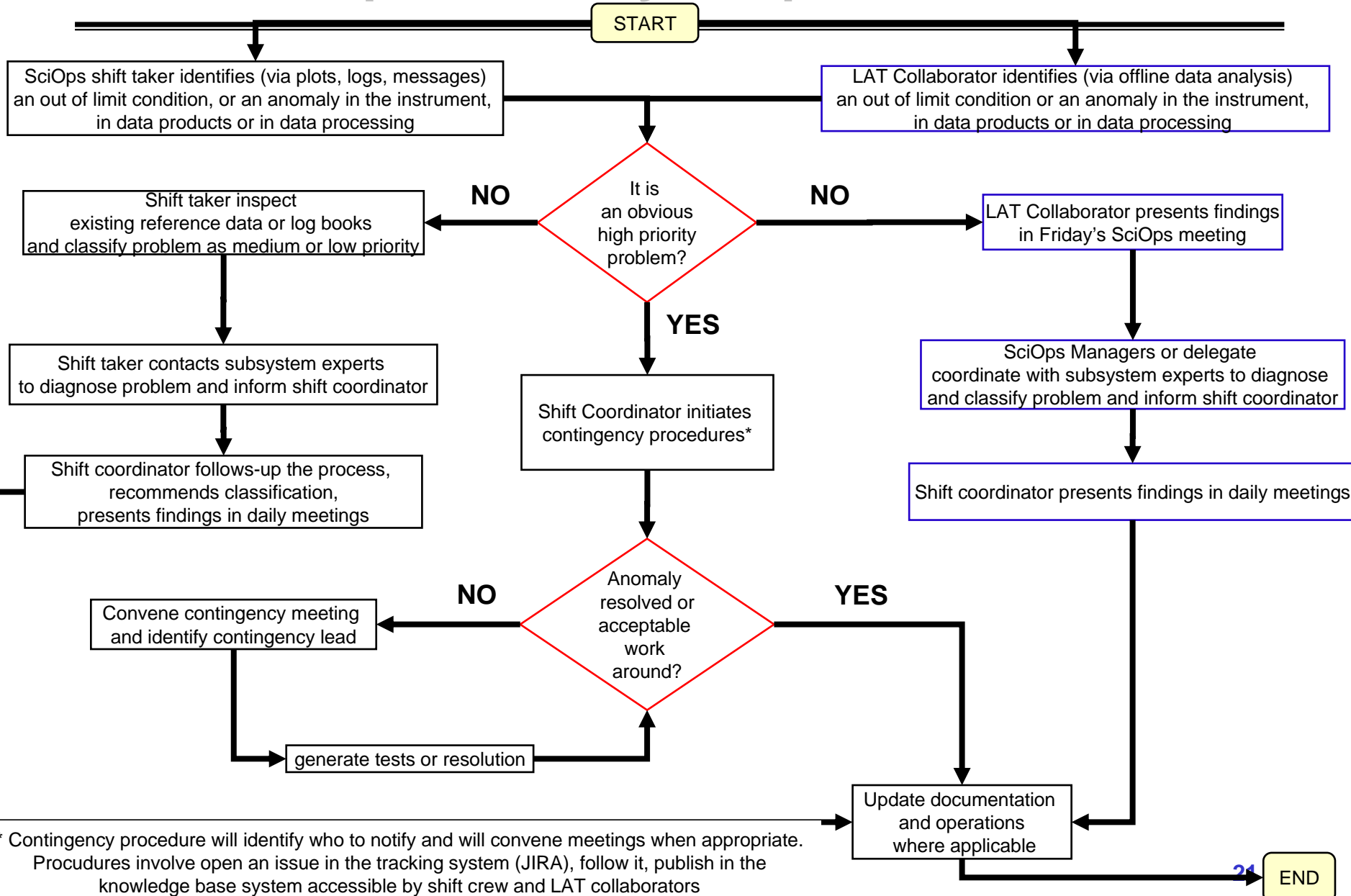

* Contingency procedure will identify who to notify and will convene meetings when appropriate. Procedures involve open an issue in the tracking system (JIRA), follow it, publish in the knowledge base system accessible by shift crew and LAT collaborators