

GLAST Large Area Telescope Instrument Science Operations Center

ISOC Status

Robert Cameron
ISOC Manager
rac@slac.stanford.edu



Outline

- ❑ **Overview**
- ❑ **Flight Operations Status**
 - **Software development examples**
 - **Development Schedule**
- ❑ **LAT Operations Facility at SLAC**
- ❑ **Operations Development and Test**
 - **Test Schedules**
 - **Operations procedure development status**

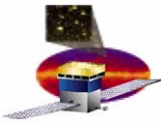

ISOC Overview

All ISOC elements continue to support LAT and GLAST I&T efforts while preparing for on-orbit operations

- ❑ **Flight Operations**
 - **Commanding, Health and Safety**
 - Continuing development of operations software
 - Coordinated development and test of on-orbit operations procedures and displays with NASA
 - Preparation for supporting GLAST ground system operational tests and simulations
 - **Flight Software**
 - Continued effort to complete requirements
- ❑ **Science Operations**
 - LAT collaboration participation being solicited and organized
 - Ramping up in areas of data processing, calibrations and configuration, monitoring and analysis, optimization, and operations
 - **More details in presentation by Seth Digel**
- ❑ **Science Analysis Systems**
 - Supporting LAT Service Challenges
 - Management of computing resources and infrastructure
 - Continued software development
 - **More details in presentation by Richard Dubois**



Flight Operations Status

- ❑ Ric Claus now leading combined software development for I&T Online and ISOC CHS
 - Ensures unified development and control of software tools needed for I&T and ISOC Flight Operations, e.g. LICOS, MOOT
- ❑ David Decotigny (IN2P3) joined ISOC in November 2006, and is making good contributions
 - To date:
 - Developed LATC_vrfy: verification tool for LAT DAQ configuration files, which interfaces to LAT configuration tracker (MOOT)
 - Prototyped integration of LATC_vrfy with FSW LATC module
 - Extensions to LAT configuration database access GUIs
 - Future:
 - Developing uniform installation procedure for the ISOC environment on production servers and developers' AFS accounts
 - MOOT extensions: e.g. support for tracking to LAT ancillary calibration and configuration files
 - Automatic documentation diagrams and SQL code generator for the XML database description files used by MOOT.

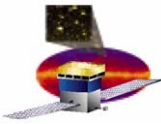

LAT Mission Planning Tools

- ❑ GUI suite for planning LAT on-orbit activities
 - LAT “Activity” manager
 - On-board LAT Absolute Time command Sequence (ATS) builder
 - File upload scheduler
 - Science run scheduler
 - Real-time PROC scheduler
- ❑ Connected to MP databases
 - Orbit data and events
 - FSW files
 - LAT PROCs
 - LAT commands
- ❑ Generates NASA/ISOC ICD-compliant products

The screenshot shows the 'ATS List' window with a table of commands and their parameters. The table has columns for Time, Type, and Command. The data is as follows:

Time	Type	Command
2007-04-01 02:32:14.164000	CMD	LCMCMRESPON
-	LCMCMDACTION	EXECUTE
-	LCMCMDCCLASS	NORMAL
-	LCMCMDCLEVEL	ALL
-	LCMCMDEID	SIU
-	LCMCMDEID	LCM_TID_ANON

The right-hand side of the window contains configuration options for the selected command. The 'Command Time' is set to '2007-04-01 02:32:14.164000'. The 'Trigger' checkbox is checked, and the 'Absolute' checkbox is unchecked. The 'Trigger Edge' is set to 'Start'. The 'Delta Seconds' is set to '0'. Below this is a table of events:

Orbit	Event	Start
2	LAT_SAA 2007-04-01 02:32:14.164000	
3	LAT_SAA 2007-04-01 04:08:29.930000	
4	LAT_SAA 2007-04-01 05:47:21.487000	
5	LAT_SAA 2007-04-01 07:27:05.566000	
6	LAT_SAA 2007-04-01 09:07:57.707000	
7	LAT_SAA 2007-04-01 10:49:56.284000	
17	LAT_SAA 2007-04-02 02:27:32.750000	

Below the event table, the 'Command Mnemonic' is set to 'LCMCMRESPONSE'. The 'Telecommand' checkbox is checked, and the 'RTS' checkbox is unchecked. The 'View...' button is visible. At the bottom of the window, there are 'Add', 'Update', and 'Remove' buttons.

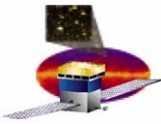

LAT Configuration Control

- ❑ LATC configuration management system (MOOT) now deployed with I&T online systems
- ❑ I&T configurations used to populate configuration database
 - Database mirrored between SLAC and LAT EGSE at General Dynamics
- ❑ Next steps
 - Put other LAT ancillary data into MOOT DB
 - Include FSW configuration files in MOOT DB

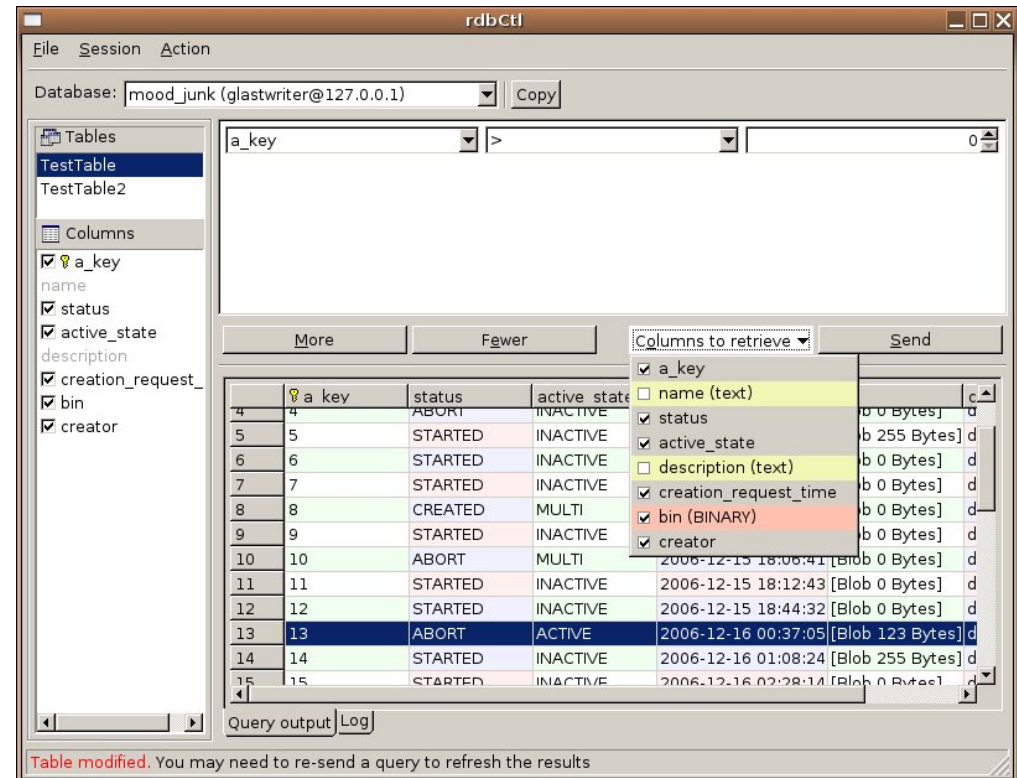

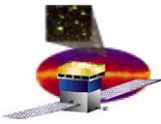

Release Status and Plan

Requirement Category	Release Status & Plan (as of 01/30/07)									total
	1 6/05	1.2 11/05	1.3 2/06	1.4 5/06	2 7/06	2.1 10/06	2.2 2/06	3 4/07	4 6/07	
	GRT2	GRT3			GRT5	GRT6	MPE ETE1	GRT7 ETE2-3	ETE4-6	
Misc (Facility, Redundancy, Security, Doc, etc.)	3	1		2	7	2	4	16	27	62
Mission Planning	2	2					30	16	3	53
Telemetry Processing	1	3	1	7	4	13	3	10	2	44
Science Data Processing				1	2	3		29	1	36
Telemetry Monitoring		1	1	2	1	15	1	10	2	33
Logging			3			4		3		10
Trending			12		6	3		1		22
Anomaly Tracking & Notification						6	3	7	1	17
# new reqts verified	6	7	17	12	20	46	41	92	36	277
cumulative total	6	13	30	42	62	108	149	241	277	

Key:	
	Incremental release (only new requirements tested)
	Major release (all requirements satisfied to date tested)

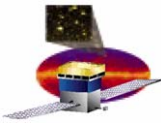

ISOC Releases

Rel #	Date	Supports	Content
2.2	2-Feb-07	DITL, GRT 6, ETE 1	<ul style="list-style-type: none">•mission planning: GUI, activity input, activity feedback•anomaly tracking with Jira•SAA update procedure•Narrative Procedure standards verification
3.0	16-Apr-07	ETE 2-3, GRT 7	<ul style="list-style-type: none">•refinements to mission planning•calculate derived low-rate science counter params from L0 data•log alerts from L0 telemetry•electronic logbook•calibration trending (calib db & plots)•LAT configuration tracking & management•reports•process science data into level 1 & 2 products & send to GSSC•generate & send GCN notices
4.0	4-Jun-07	ETEs 4-6, Mission Sims	<ul style="list-style-type: none">•refinements to mission planning•refinements to LAT config tracking & management•GUI enhancements



ISOC operations facility

- **ISOC Operations Facility**
 - **Construction is completed**
 - **Operations area has been created**
 - **Adjacent office cubicles for ISOC staff**
 - (still missing a few pieces of furniture)
 - **LAT dataflow lab area increased by merging with adjoining room**
 - **Operations computers installed**
 - **5 workstations**
 - **Video switch to overhead monitor**
 - **Networking**
 - **Dedicated SLAC subnet for operations computers, as “Internet Free Zone”**
 - **Office phones will be used for communication with external elements**
 - **patched into operations voice circuits at NASA/GSFC MOC**
 - **GLAST I&T at General Dynamics factory**
 - **Essentially ready to support GLAST operations testing**



Operations Area



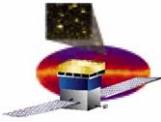

Dataflow Lab

- We now have space for the LAT Calibration Unit!
 - Should be returning to SLAC in March, following shipping review



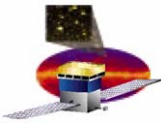

GLAST operations testing

- ❑ GLAST ground system takes control of the observatory in End-to-End (ETE) tests
- ❑ Intent of the ETE tests
 - Exercise and verify operations interfaces and coordination
 - Exercise and validate all operations procedures
- ❑ GLAST Observatory functions should all be tested in Comprehensive Performance Test prior to first ETE test
 - Constraint on ETE scheduling

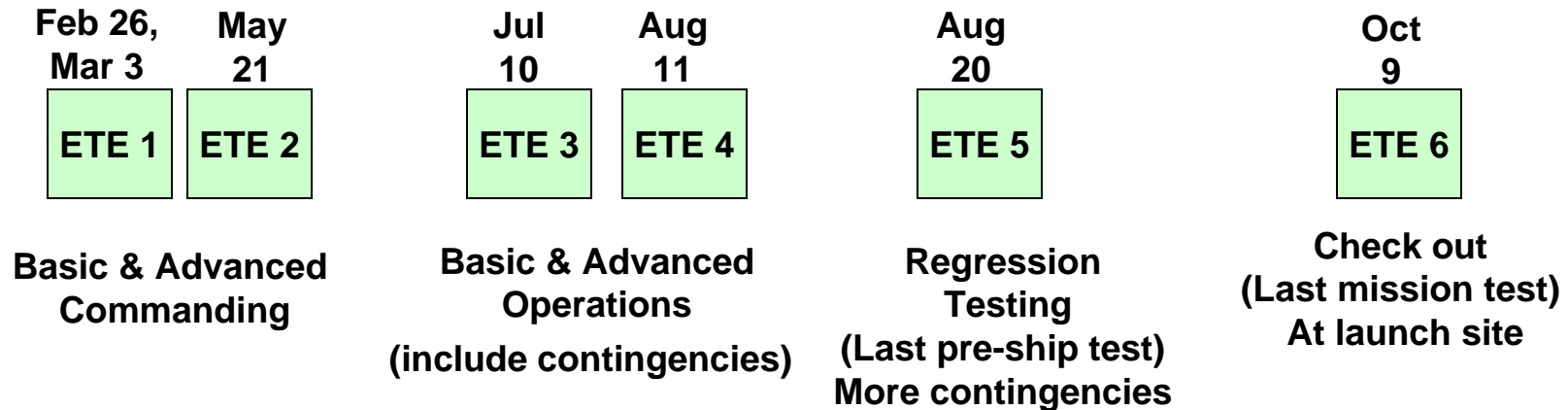

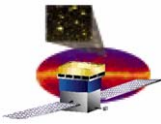

ETE Test Primary Functions

- ❑ **Send Instrument timelines and commands**
 - **from the Instrument Operation Centers (IOCs) to the GSSC**
- ❑ **Integrate the two IOC timelines and commands into an integrated science timeline and send it to the MOC**
 - **done by the GSSC**
- ❑ **Commands are sent from the MOC through the RF equipment to the spacecraft**
 - **done by the MOC**
- ❑ **Telemetry is sent from the spacecraft through the RF equipment to the MOC**
 - **Sent by the Observatory**
- ❑ **Transfer Level-0 science data to the GSSC and IOCs (LAT and GBM)**
 - **done by MOC**
- ❑ **Generate Level-1 products and send them to GSSC**
 - **done by IOCs (LAT and GBM)**
- ❑ **Send housekeeping (HK) telemetry to the IOCs (LAT and GBM)**
 - **done by the MOC**
- ❑ **File management, memory dumps, solid state recorder (SSR) operations, commands, command loads, and memory loads will also be exercised during these tests**

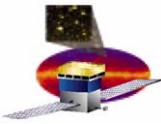

ETE Nominal Data Flow

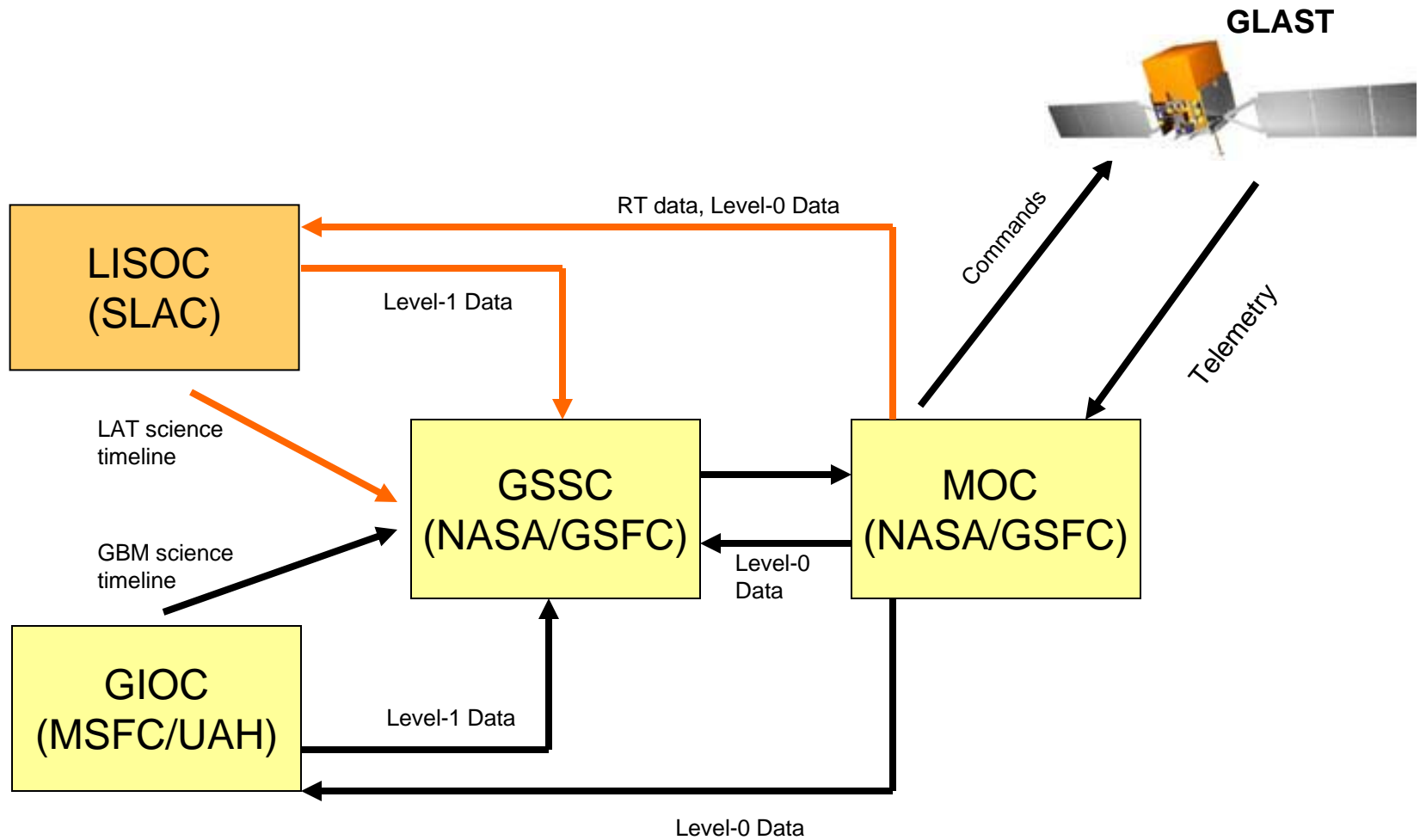

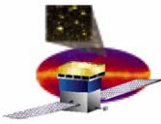

On-Orbit Operations Procedure Development

- ❑ Real-time commanding of the LAT through the MOC uses scripted PROCs
- ❑ All commands in the T&C database delivered to the MOC are included in a narrative procedure (NP)
- ❑ All procedures to be exercised during ETEs
 - Development schedule is tied to ETE schedule
- ❑ Procedures reviewed by systems engineering and FSW
- ❑ Separate procedures for planned L&EO activities
- ❑ Contingency procedures included
- ❑ MOC creates STOL PROCs from NPs
- ❑ PROCs are verified against LAT testbed

Status by ETE								
ETE	Date	# of Procedures	Level					
			1	2	3	4	5	6
ETE 1	Feb-07	9	0	0	0	0	9	0
ETE 2	Mar-07	21	0	0	17	3	1	0
ETE 3	Apr-07	23	9	1	14	0	0	0
ETE 4	Jun-07	41	10	0	8	0	0	0
		94	19	1	39	3	10	0

Schedule				
	Planned Draft	Draft Actual	Planned Level 3	Level 3 Actual
Apr	3	4	0	0
May	7	8	0	0
Jun	9	5	0	0
Jul	4	0	2	2
Aug	6	8	1	1
Sep	4	9	11	11
Oct	6	7	12	11
Nov	12	11	8	16
Dec	13	12	2	1
Jan	9	8	16	10
Feb	10	0	16	0
Mar	6	0	11	0
Apr	5	0	10	0
May	0	0	5	0
	94	72	94	52

Cumulative NP Progress				
	Planned Draft	Draft Actual	Planned Level 3	Level 3 Actual
Apr	3	4	0	0
May	10	12	0	0
Jun	19	17	0	0
Jul	23	17	2	2
Aug	29	25	3	3
Sep	33	34	14	14
Oct	39	41	26	25
Nov	51	52	34	41
Dec	64	64	36	42
Jan	73	72	52	52
Feb	83		68	
Mar	89		79	
Apr	94		89	
May	94		94	

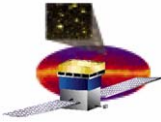

End-to-End Test 1

- **Readiness for ETE1**
 - 13 LAT PROCs to be exercised in ETE1
 - Relatively simple: NOOPs, diagnostic messages, file system tests
 - Mali Hakimi is ETE test lead for ISOC
 - ISOC will have LAT representative at the MOC
 - PROCs verified on LAT testbed at SLAC
 - Planning for 12 hour LAT physics run, with gamma filter “on”
 - I&T turns LAT on/off and starts physics run
 - SLAC facilities ready
 - ISOC core software 2.2 released and tested
 - Improvements to SLAC processing pipeline on schedule
 - LAT FSW B0-8-0 Telemetry & Command DB approved
 - No change to T&C DB expected for any new FSW load before ETE1
 - LAT participation in ETE1 will be interrupted if LAT reboot occurs
 - To do:
 - Deploy general-purpose and test-specific housekeeping displays
 - Connectivity check between MOC and new server at SLAC

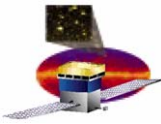

More Testing: GRTs and Mission Simulations in 2007

□ Ground Readiness Tests (GRTs)

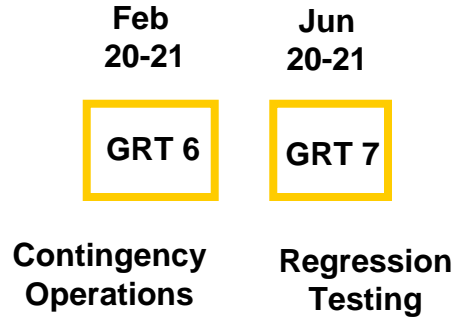

All dates subject to change

□ Mission Simulations

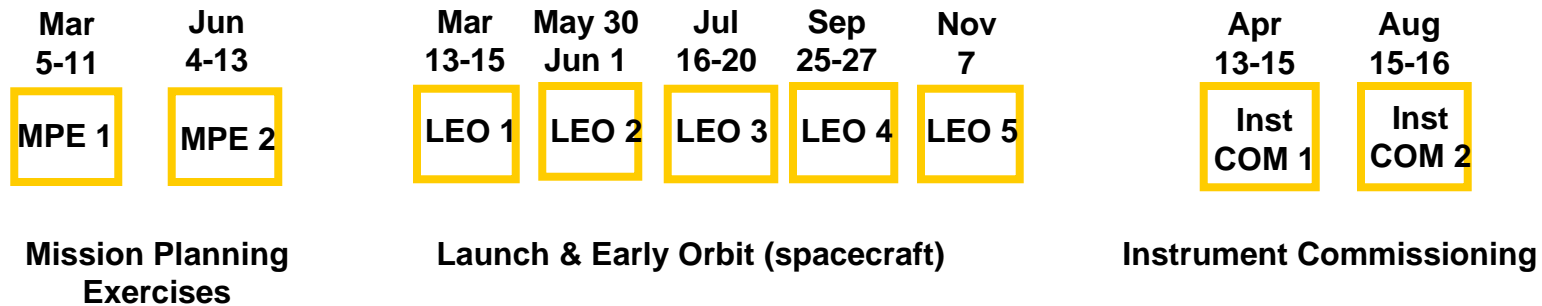

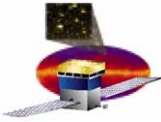

Summary

- ❑ **An ambitious GLAST ground operations test schedule is starting, compressed by remaining completion of Observatory integration and functional testing**
 - **All ISOC elements hard at work preparing for launch and mission**
- ❑ **Success of the ISOC depends on collaboration participation and support, particularly in Science Operations and SAS**