

National Aeronautics and Space Administration



# Fermi

Gamma-ray Space Telescope

## Analysis Coordinator's Report

**Gino Tosti & Eric Charles**



## Outline

---

- **Scientific organization of the collaboration and service work**
- **Status of publications and recent analysis highlights**
- **Ongoing work and working towards year 5**

# Our Activities

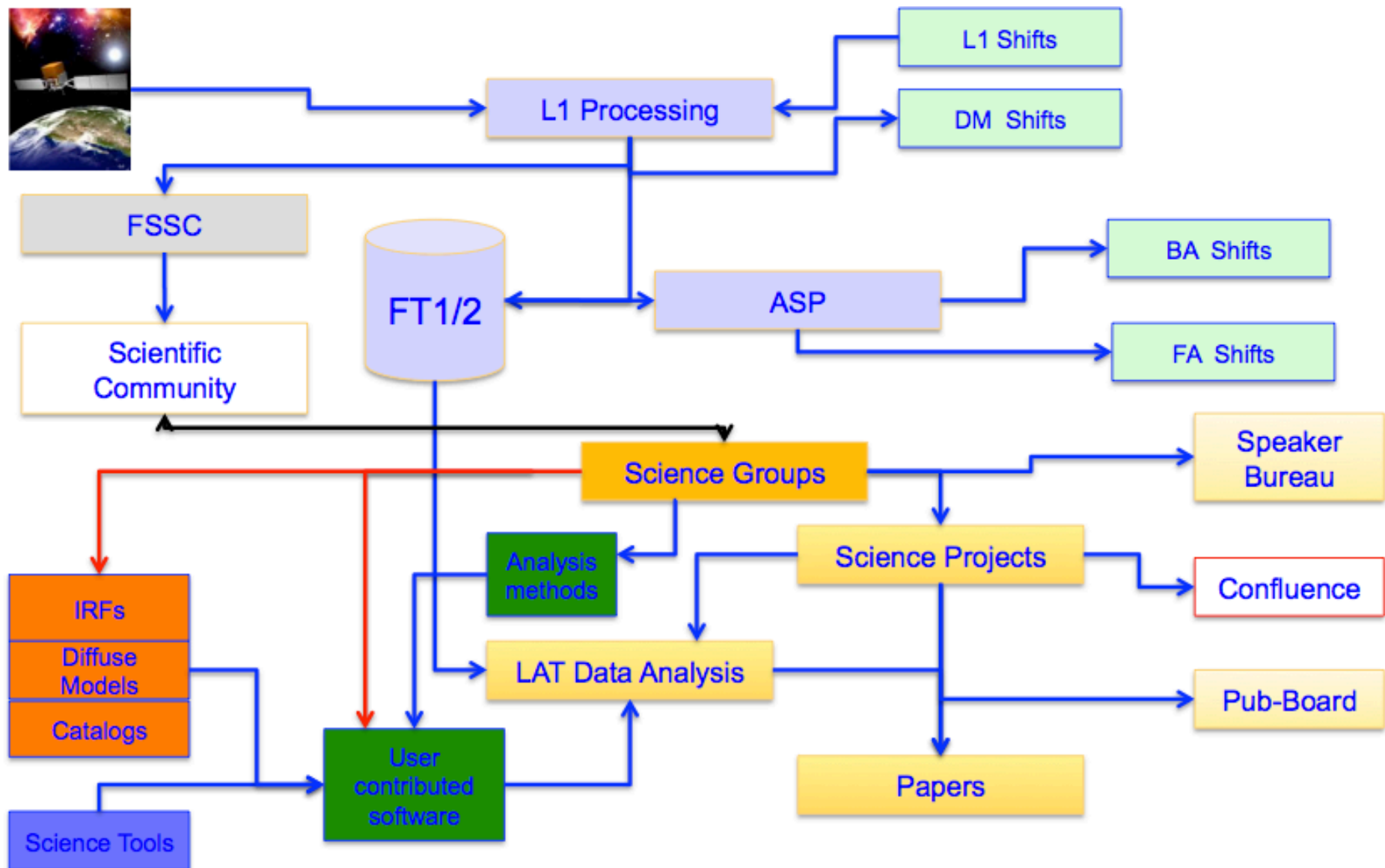



# Scientific Organization of the Collaboration and Service Work

## Science Working Group Membership

---

- From the database: 457 collaboration members
- Full members (119), Affiliated(111), Postdoc (93) and Students (134)
- On average each member is subscribed to 2.40 science groups, making the number of Science group members exactly 1099

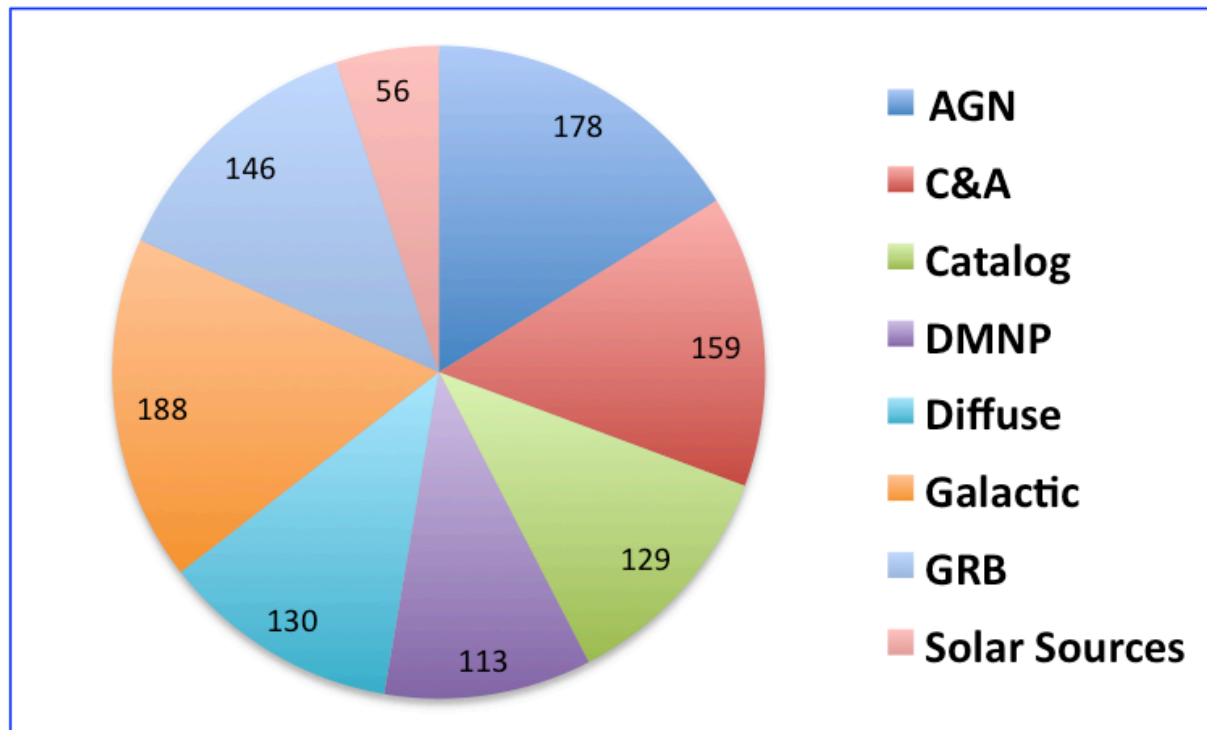



## Focusing Responsibility on Group Leads

---

- **As collaboration matures, procedures and responsibilities are evolving**
  - **Science groups and group leads are often the best placed to make decisions**
    - **Selecting internal reviewer for papers, leading initial review of figures for public release, resolving issues with papers and analyses**
  - **Also best placed to keep collaboration members well informed**
    - **Important development in other groups that might impact work**
    - **Help new members with collaboration review procedures**



# Science Group Coordination

---

Calibration & Analysis	Luca Baldini Leon Rochester	Luca Baldini Leon Rochester
Dark Matter & New Physics	<b>Steve Ritz</b> Luca Latronico	<b>Jennifer Siegal-Gaskins</b> Luca Latronico
Diffuse	Jean-Marc Casandjian <b>Gulli Johannessen</b>	<b>Luigi Tibaldo</b> Gulli Johannessen
Catalog	<b>Dave Thompson</b> Isabelle Grenier	Elizabeth Ferrara Isabelle Grenier
Solar System	<b>Francesco Longo</b> <b>Nicola Giglietto</b>	<b>Nicola Omodei</b> Nicola Giglietto
AGN	<b>Stephan Fegan (March 2012)</b> <b>Justin Finke</b>	<b>Marco Ajello (Nov 2011)</b> Justin Finke
Galactic Sources	<b>Pablo Saz Parkinson</b> <b>Francesco Giordano</b>	<b>Paul Ray</b> Francesco Giordano
GRB (LAT members)	<b>Vlasios Vasileiou</b> <b>Judith Racusin</b>	Vlasios Vasileiou Judith Racusin



**Huge amount of organizational work is done by group leaders  
We are lucky to have some many skilled people willing to step up**



# Communication Between Science Groups

---

- Many issues and projects, important to draw attention to those which have the most effect on analysis
- 3 Forums to manage discussion
  - Science group coordinator's meeting
    - Keep track of upcoming papers and projects
    - Identify issues of interest to multiple groups
  - Weekly analysis meeting (~40-75) attendees
    - “Formal” presentation of results prior to publication
    - Summary presentation of ongoing work with wide ramifications
  - Calibration and Analysis group meeting
    - Detailed discussion and study of important analysis issues

## Push to Recruit Shifters

- **Started actively recruiting Data Quality Shifters**
  - **Requires about 1 hour /day for 1 week / year**
  - **Good response (shifts filled through spring)**
    - **Needs follow up, still many people who have not taken shifts**

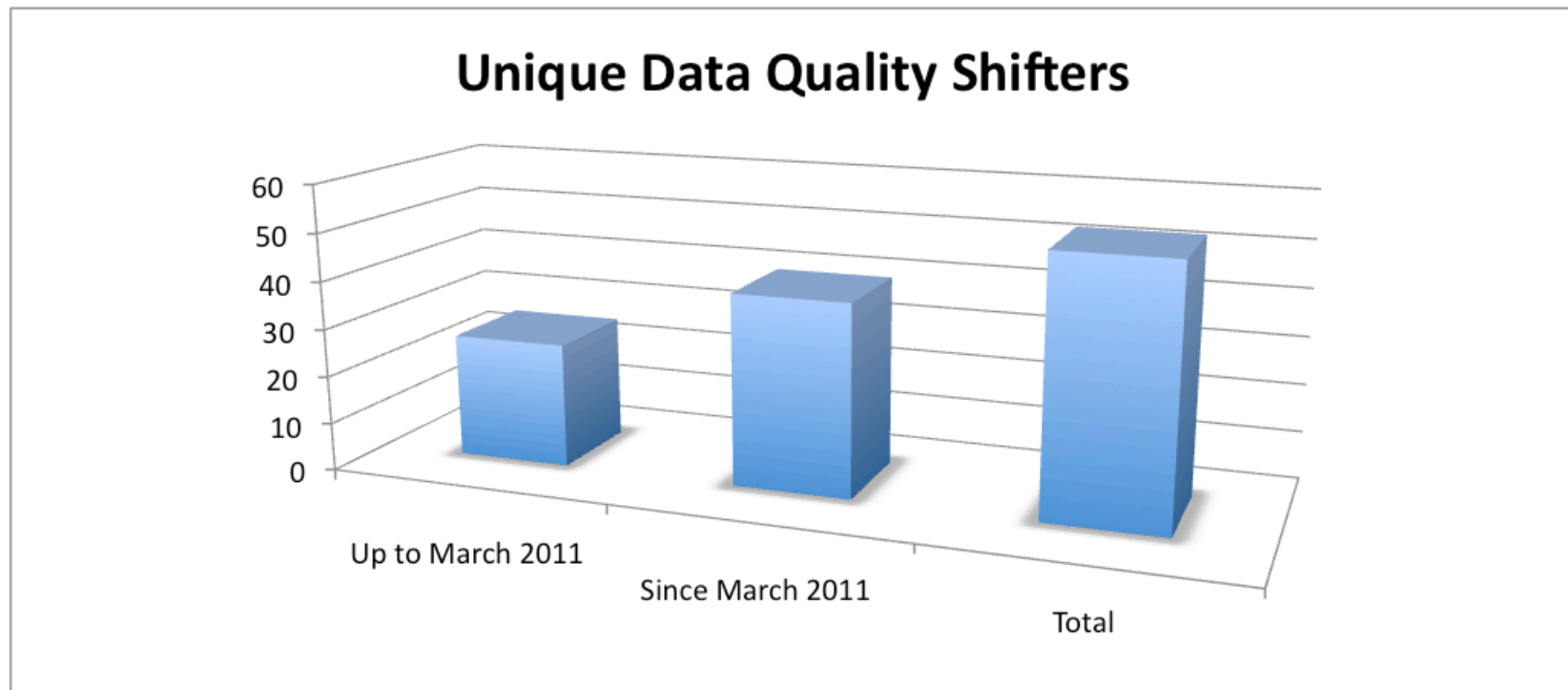

## Other ways to help the Collaboration

---

- **Participating in working groups studying key issues**
  - **Improving instrument reach to lower and higher energies**
    - **Esp. pass 8, but also other studies**
      - Pisa, SU/SLAC, UCSC, Ecole Poly., GSFC/UM, NRL ...
    - **Studying systematic effects relevant for particular analyses**
      - UW, SU/SLAC, Ecole Poly., Saclay, Pisa, Padova, Bari ...
- **Managing analysis pipelines for validation/ calibration studies**
  - **Defining and providing datasets for specific analyses**
    - Pisa, Stockholm, SLAC, Montpellier ...
- **Burst and Flare Advocates**
  - Perugia, Hiroshima, JAXA, GSFC, SU/SLAC ...
- **Group Coordination**
  - NRL, SU/SLAC, Pisa, Caltech, Torino, Saclay, GSFC, Iceland, Padova, Montpellier, UCSC, Perugia ...



# STATUS OF THE PUBLICATIONS

## (Cat I & II) Papers Published by Journal

Journal	Published	In press	Total
	-	0+1=1	1
Astronomy and Astrophysics	5+6=11	0+1=1	12
Astroparticle Physics	1+2=3	-	3
Astrophysical Journal	56+14=70	4+4=8	78
Astrophysical Journal Letters	20+7=27	-	27
Astrophysical Journal Supplement	3+1=4	-	4
Journal of Cosmology and Astroparticle Physics	2+2=4	-	4
Monthly Notices of the RAS	0+4=4	0+1=1	5
Nature	2+1=3	-	3
Physical Review D	4+0=4	-	4
Physical Review Letters	4+0=4	1+0=1	5
Science	10+0=10	1+0=1	11
<b>Total</b>	107+37=144	6+7=13	157

Number of Cat III papers published = 67

Number of Astronomer's Telegrams = 164+ (~1 / week)

Number of GCN notices = 37+



**+MW follow ups**



## Science Impact from Past Years

---

- **Paper citations for 2009 (from ADS) – 7 of the top 100**
  - LAT Instrument paper (#6)
  - CR electrons (#7)
  - Bright Source List (#19)
  - LAT Bright AGN Sample (#34)
  - GRB 080916C (#25)
  - CR electron interpretation (#66)
  - GRB 090902B (#100)
  
- **Paper citations for 2010 (from ADS) – 6 of the top 100**
  - 1FGL Catalog (#5)
  - 1<sup>st</sup> Pulsar Catalog (#11)
  - Isotropic Diffuse spectrum (#16)
  - 1<sup>st</sup> AGN Catalog (#18)
  - dSph DM limits (#42)
  - Blazar SED (#64)



## Status of Major Papers for 2011

---

- **2<sup>nd</sup> Fermi LAT AGN Catalog -> Accepted and on arXiv**
- **2<sup>nd</sup> Fermi LAT Source Catalog -> Submitted and on arXiv**
- **Galactic Diffuse Model -> Submitted**
- **2<sup>nd</sup> Fermi LAT Pulsar Catalog -> Under review in Gal. Group**
- **Fermi GRB Catalog -> Under review in GRB Group**
- **Instrument Performance -> Under review in C&A Group**
- **SNR and PWNe Catalogs -> In preparation in Gal. Group**

## Recently Published Papers (Since May 2011)

II	AGN	A&A	HESS J1943+213: a BL Lac?	II	darkmat	MNRAS	Anisotropic Diffuse Gamma-Rays
II	AGN	ApJ	Bright gamma-ray Outbursts from 4C 21.35	I	galactic	ApJL	PSR B1259-63 Periastron
II	AGN	MNRAS	Flare of NLS1 J0948+0022	II	galactic	ApJ	CRTS100217: A possible hypernova
II	galactic	ApJ	Two Nancay MSPs	II	galactic	MNRAS	UID LAT source 1FGL J1227-4852
III	galactic	A&A	Gamma ray absorption in Cyg X-3	I	AGN	ApJ	Fermi view of Mrk421
III	galactic	ApJ	Photon Probability Weighting	II	AGN	A&A	3C345 and NRAO512 Identification
I	AGN	ApJL	Giant outburst of 3C 454.3 in Nov. 2010	I	diffuse	Phys. Rev. D	CREs from the Sun
II	AGN	ApJL	Time Delay of Cascade Radiation	III	diffuse	ApJ	EGB Components
III	AGN	A&A	3C279 MAGIC and multiwavelength	III	diffuse	MNRAS	MSP constraints on diffuse BG anisotropy
III	AGN	ApJS	OVRO Blazar Monitoring Program	II	GRBs	Nature	Swift1644
I	galactic	ApJ	LAT Observations of RX J1713.7-3946	III	GRBs	MNRAS	Dissipative Photospheres in GRBs
II	galactic	ApJS	Timing of Fermi Pulsars	I	AGN	A&A	PKS 2005-489 Multiwavelength
II	galactic	MNRAS	Two Radio MSPs at Parkes	II	AGN	ApJ	Fermi-LAT Observations of 4C+55.17
III	galactic	ApJ	Multiwavelength study of LAT pulsars	III	AGN	A&A	Jet Structure in NGC6251
III	galactic	ApJ	X-ray counterpart of PSR J0357+3205	III	darkmat	ARA&A	DM Searches with Astroparticle Data
III	galactic	ApJ	Binary 0535+262 multiwavelength	II	galactic	A&A	PSR J1357-6429
I	GRBs	ApJL	X-ray Flare Detection	II	galactic	A&A	VLT obs. of PSRs J1357-64 and J1048-58
III	GRBs	ApJ	Spectroscopy of brightest GBM GRBs	II	galactic	ApJ	Sub-Luminous Gamma-Ray Pulsars
I	solar	ApJ	quiet sun solar emission	II	galactic	ApJ	Fermi-LAT observations of HESS J1825-137
II	AGN	ApJ	M. Boettcher's PKS0528+134 MW campaign	III	GRBs	ApJ	GRB Population Studies
				II	galactic	ApJL	SNR RX J0852.0-4622 (Vela Jr.)

# Many more papers in the works

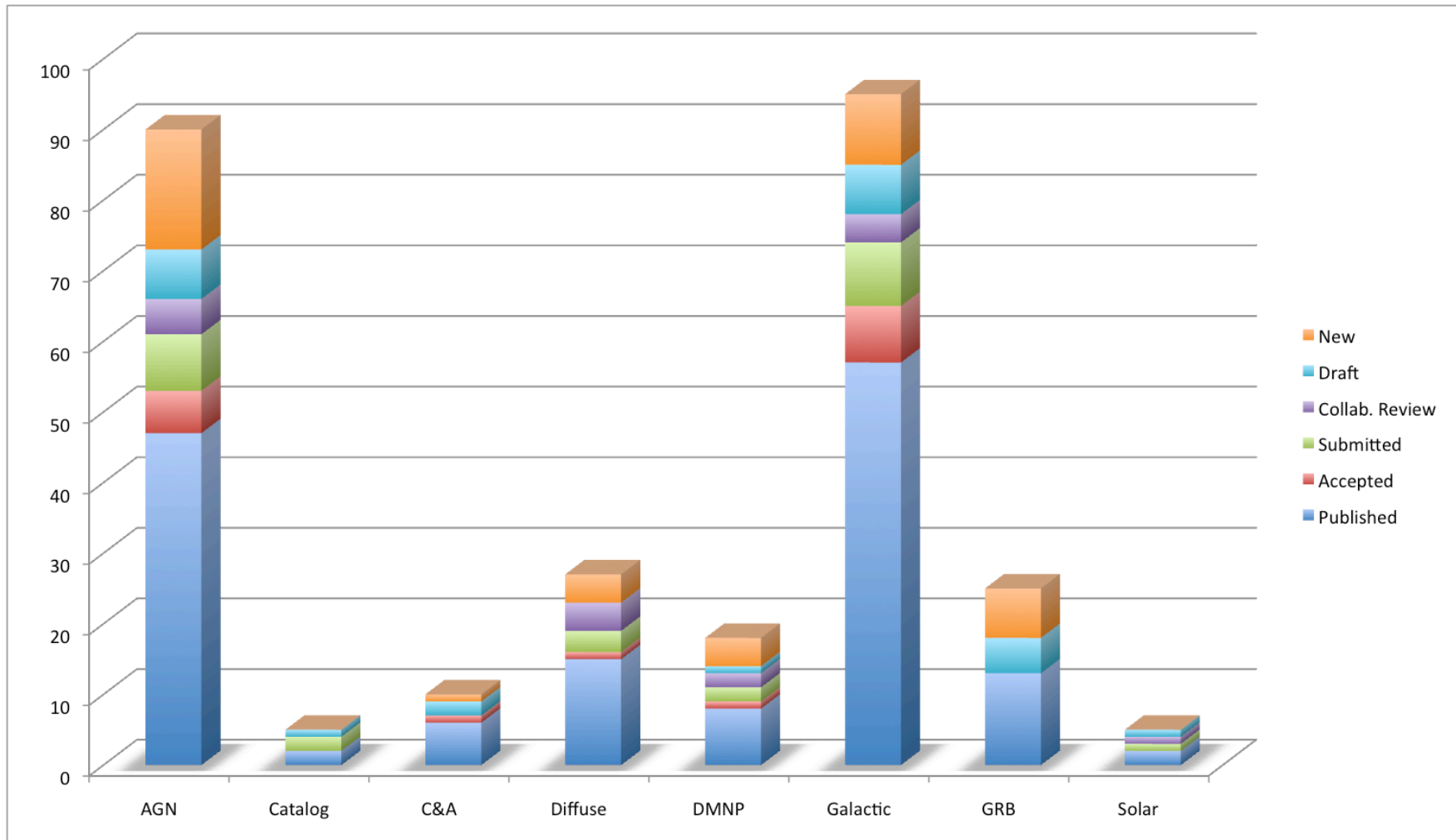



# **SOME RESULTS FROM THE AUGUST COLLABORATION MEETING**

# LAT Low Energy Analysis of Solar Flares

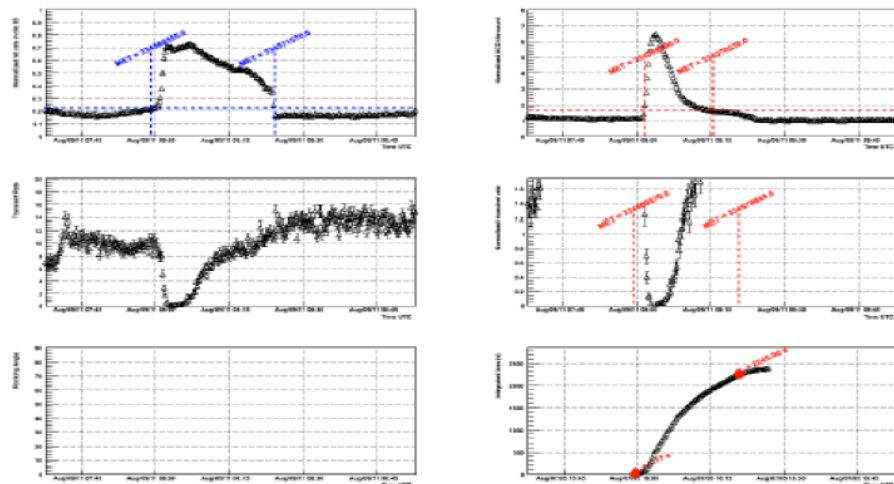

Baldini+:  
Identification of time intervals where high x-ray flux piles up in ACD and affects standard event selection.  
Now included in public data release.

Omodei+:  
Analysis of Solar Flare using LLE data

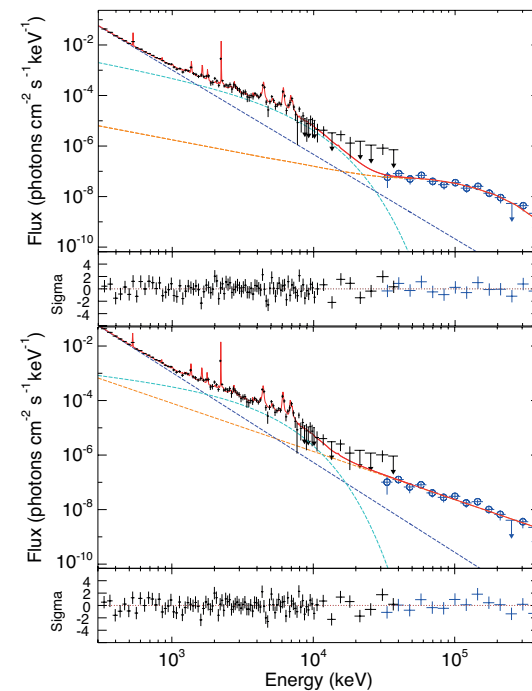
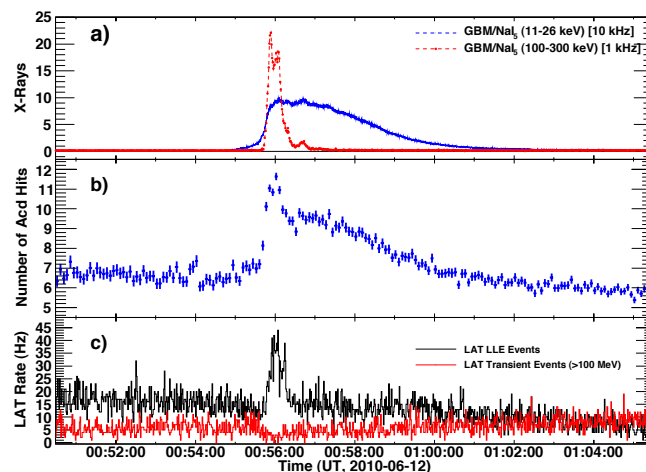

# Search for Extended Sources

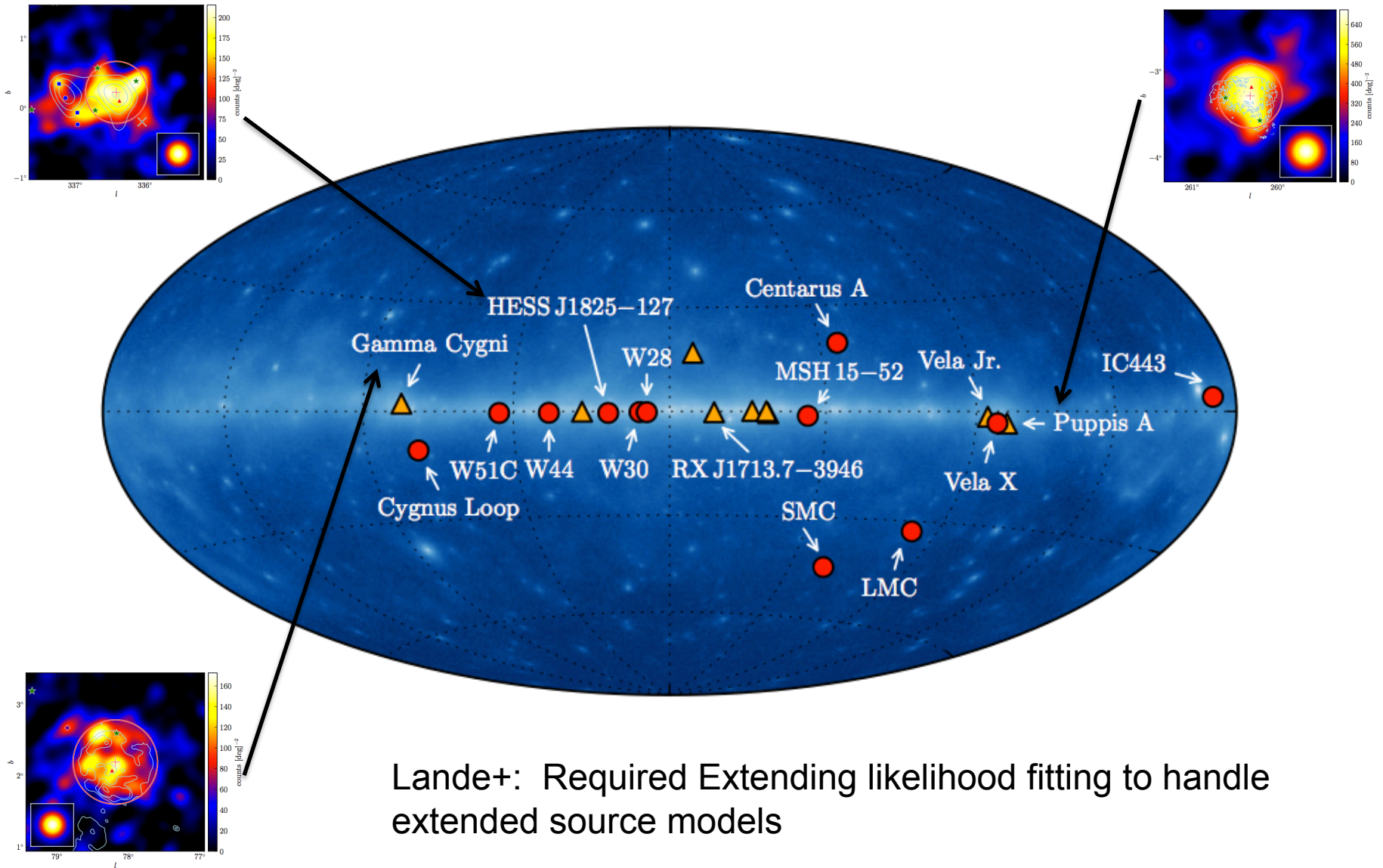

Lande+: Required Extending likelihood fitting to handle extended source models

## Detection of several TGFs

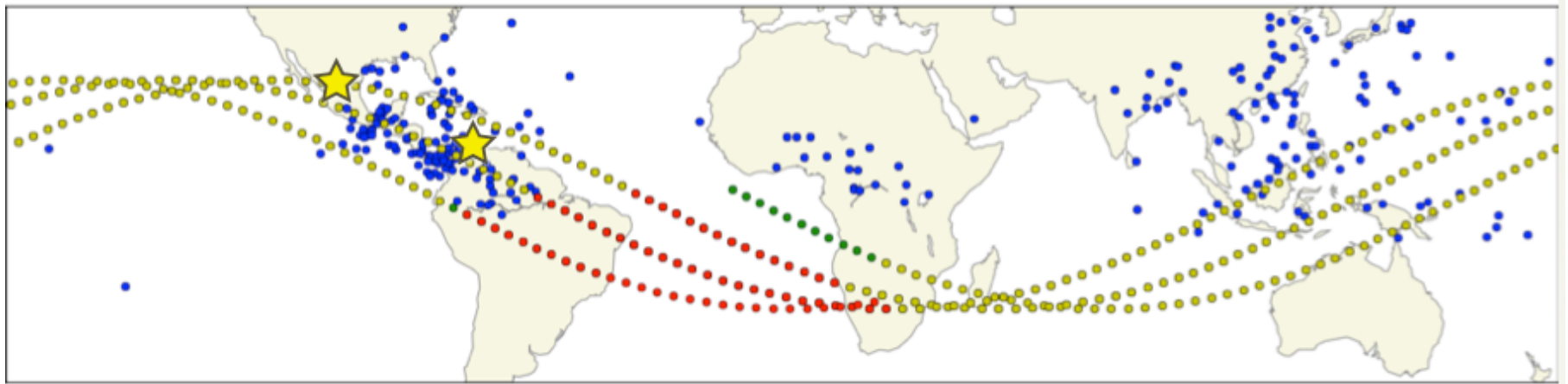

Grove+: nadir pointed orbits looking for TGFs.

Found events with evidence of extremely high  $\gamma$ -ray fluxes coincident with GBM activity

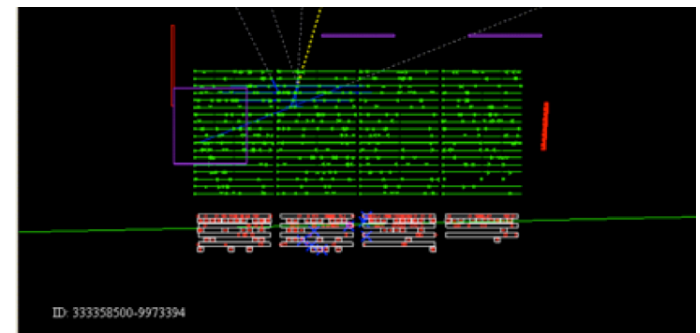
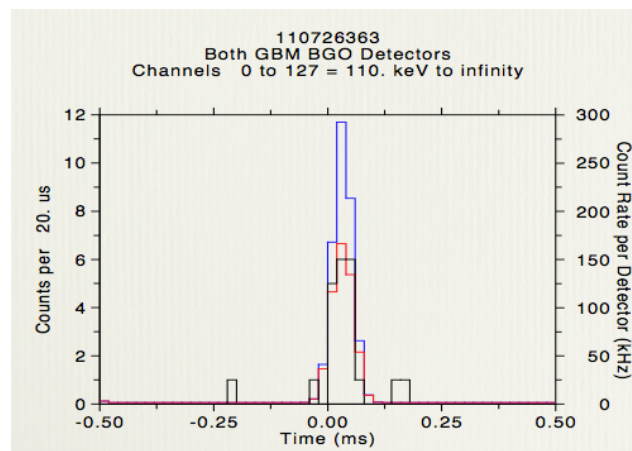



# ONGOING WORK AND TIMELINE TO YEAR 5



## A Window of Opportunity

---

- **We've finished or nearly finished many major commitments**
  - **Next set of commitments on 5 years of data**
- **Chance to review what we've done and prepare for the future**
  - **Develop new analysis techniques.**
  - **Decide what analysis issues to address to get stronger results.**
  - **Develop & standardize process for putting all the piece together**

# The Fermi Analysis Cycle

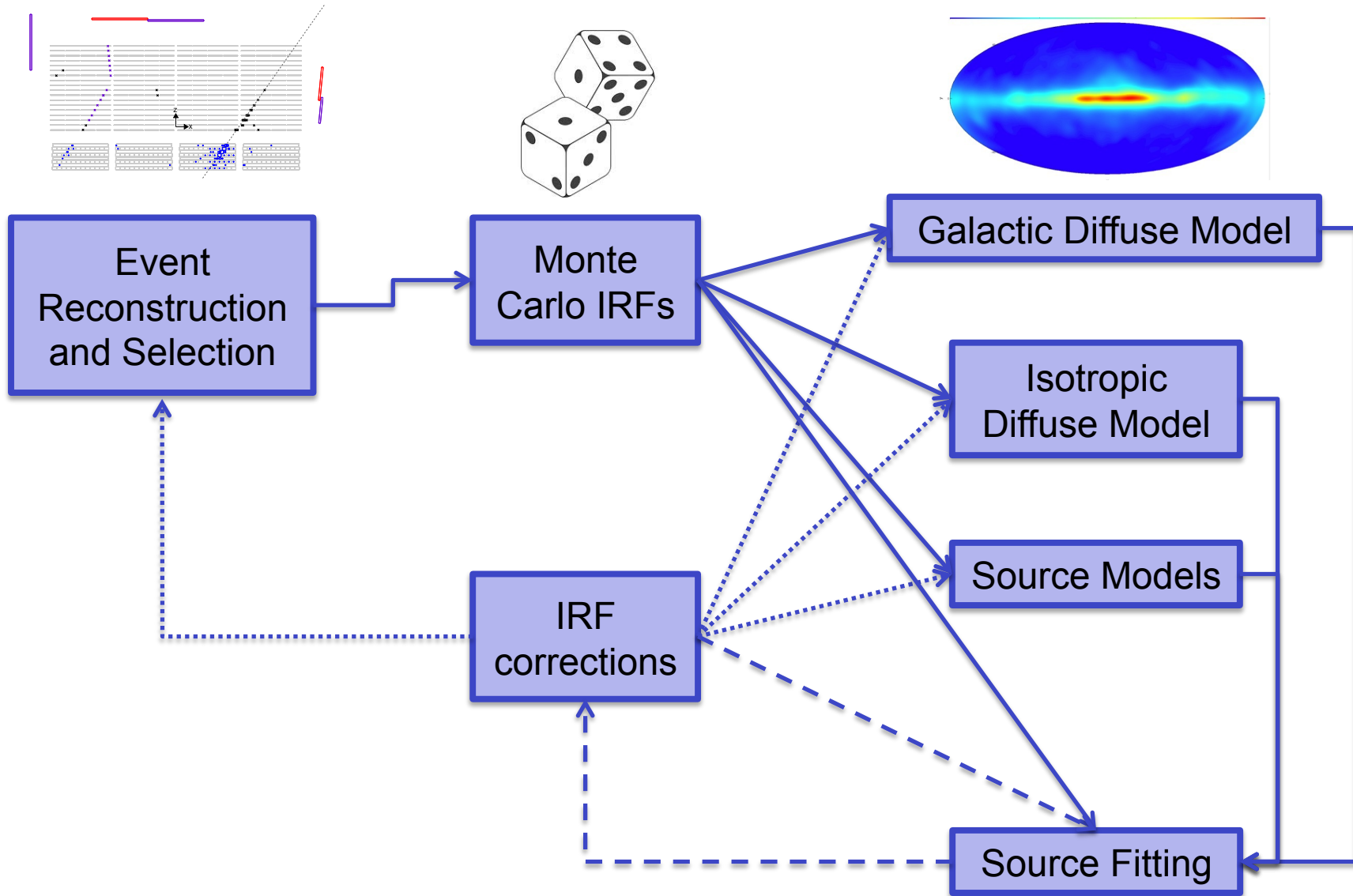

## Responsibilities for Parts of the Analysis Cycle

---

- **We've done it all once (or twice) before, time to make it routine**
- **Implement standard analyses to be done routinely as part of data release cycle**
  - **Subsystem calibrations (done already)**
  - **IRF generation (done already)**
  - **Use of control samples & IRF validation (independent of source/ diffuse models)**
  - **Generating diffuse models & earth limb templates**
  - **Standard high level analyses, including use of diffuse models**
- **Agreeing to how to share work**
  - **Acknowledge individuals who have taken up work**
  - **Put together groups to focus on specific issues**

## Identifying Ongoing Analysis Issues

---

- **Amazing performance of LAT**
  - **Exploring systematic issues at the 10% level**
- **Issues can be difficult to resolve**
  - **“Standard” analysis depends on many things**
    - **Modeling and fitting complex regions**
    - **Using very detailed instrument response model**
  - **Require diverse expertise**
    - **Every science group has different analysis issues**
      - **Transients & Variability (GRB, Solar, AGN)**
      - **Calibration Sources (C&A, Galactic, AGN, Diffuse)**
      - **Any others...**
- **Key to making progress is getting the right people working together**

## AdHoc working groups forming

---

- **Front v. Back(aka Thick v. Thin) analysis**
  - ~5% discrepancy in counts for front-converting v. back-converting events
  - Can complicate fitting of faint sources against strong backgrounds
- **Binned v. Unbinned likelihood fitting**
  - Binned and unbinned likelihood analysis have given slightly inconsistent results
    - Favor binned analysis, but would really like to resolve this
- Others likely to follow as we explore the data with greater sensitivity

## Data Updates

---

- **Pass 7 Released to public very smoothly in Aug. 2011**
- **LLE**
  - **Public release coming early 2012**
- **Potential reprocessing of data with updated calibrations**
  - **Examining cost/ benefit**
    - **Decision next week**
  - **Will require updating IRFs, minor changes to diffuse models**
- **Release of improvements and minor corrections to IRFs**
  - **Development is ongoing, planning for one iteration in the Spring 2012**
    - **May require minor changes to diffuse models**
- **Pass 8 Cycle**
  - **See Leon Rochester's talk**

## “Pass 7” event analysis

Pass 7 is first version of event analysis to use knowledge from flight data

Compensates for pile-up in electronics from cosmic-ray backgrounds

Many times more  $A_{\text{eff}}$  below 300 MeV

$A_{\text{eff}}$  curve is less steep, better for spectral analysis

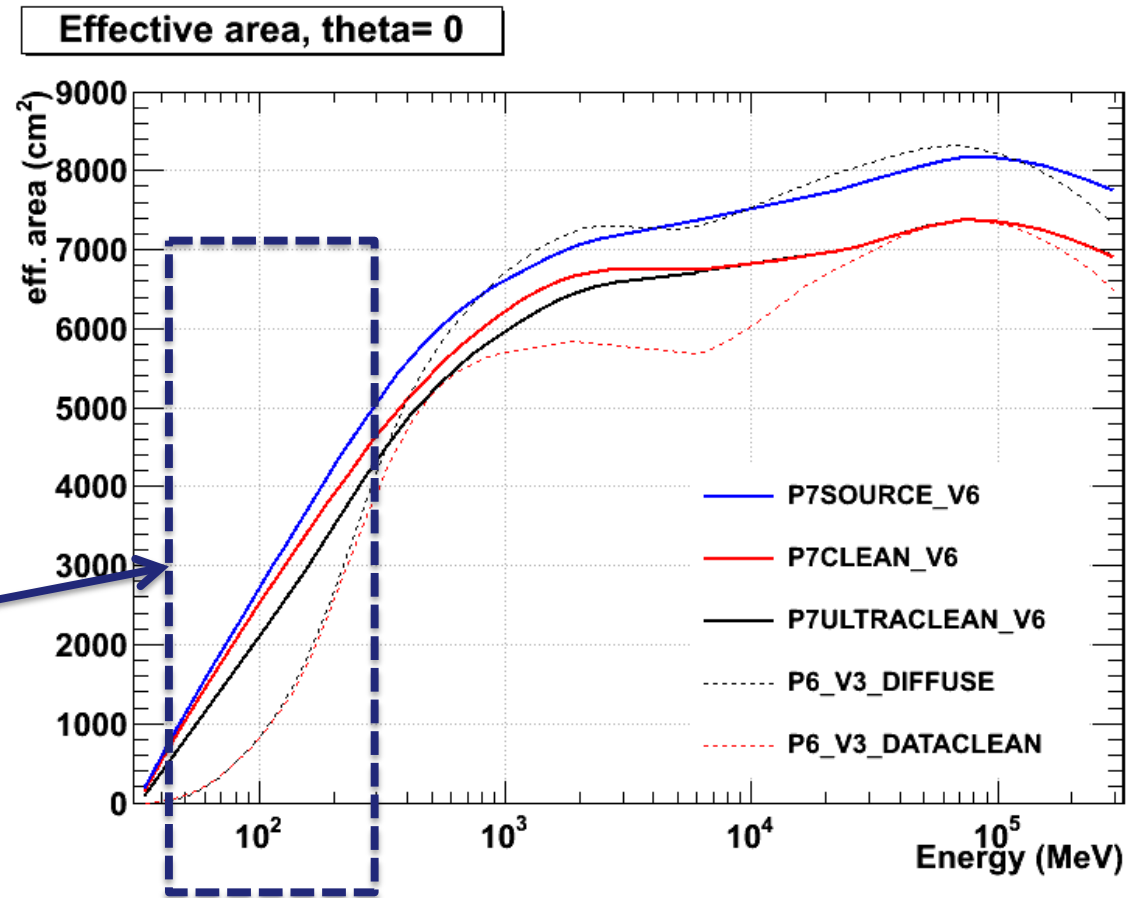

# Pass 7 and the E < 200 MeV Region

- **AGNs**
  - Define the Peak of the IC component
- **Galactic Sources**
  - Many. ie, Crab
- **GRBs & Solar flares**
  - LLE analysis (see Nicola talks) P7 extended classes
- **Solar**
  - Lunar emission
- **DMNP**
  - DM Dwarfs, Dm Spher.
- **Diffuse emission**
- **Extragalactic background**
  - Starbursts vs AGNs

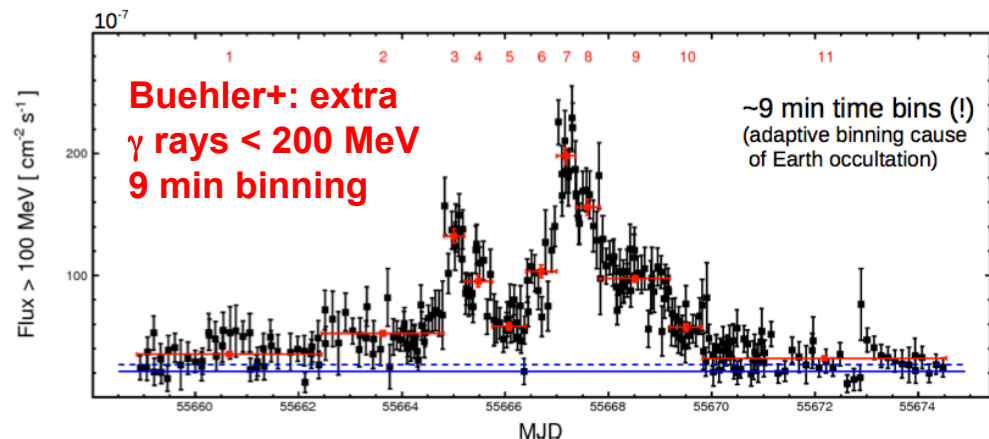
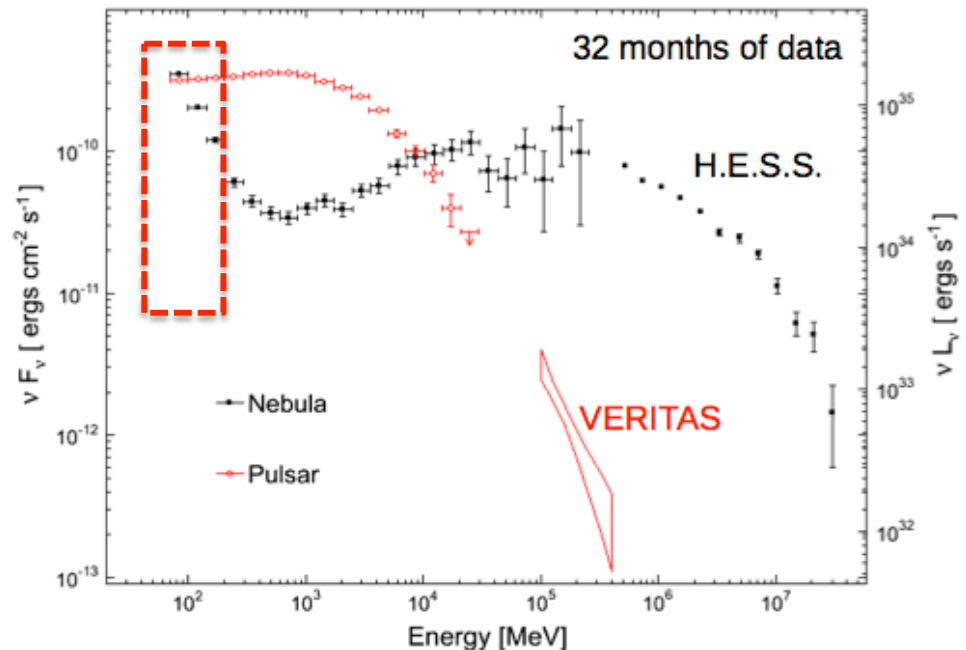

## Ongoing Science Group Activities

	Recent & Current Work	Next Year	2013 and beyond
Catalog	2FGL	Updates to 2FGL, unid sources, transients	5 year catalog
C&A	PASS6, PASS7	PASS7 + Low & High energy extensions	PASS8
DIFFUSE	P7-based ring model, Cygnus, Orion regions	Anisotropy studies, GALPROP comparisons	Extend energy range using PASS8
AGN	2LAC, AGN population, EBL, non-blazar AGN	Contributions to the EBL, AGN variability	See Gino Tosti's Talk
Galactic	100 Pulsars, populations, binaries, extended sources	Pulsar, PWN and SNR catalogs, MSP & blind searches,	See Peter's Talk
GRB	LAT GRB Catalog, LLE	LLE, extension to low energies	See Nicola Omodei's Talk
DM&NP	dSph, Clusters, Lines (2 Years)	Anisotropy studies, GC, updates with PASS7 data	See Steve Ritz's Talk
Solar	First Solar Flare	Solar Max, extension to low energies	See Nicola Omodei's Talk

## Summary

---

- **Collaboration is doing well**
  - **Extremely productive**
  - **Work and responsibilities being shared**
- **Take advantage of gap in scheduled deliverables to put things in order for the future**
  - **Develop new analysis techniques**
  - **Planning for 5 year source catalog and associated analyses**
    - **Make analysis cycle routine**
- **Thank You!**