

ACD PER



8 June 2005

GLAST

Gamma-ray Large  
Area Space  
Telescope

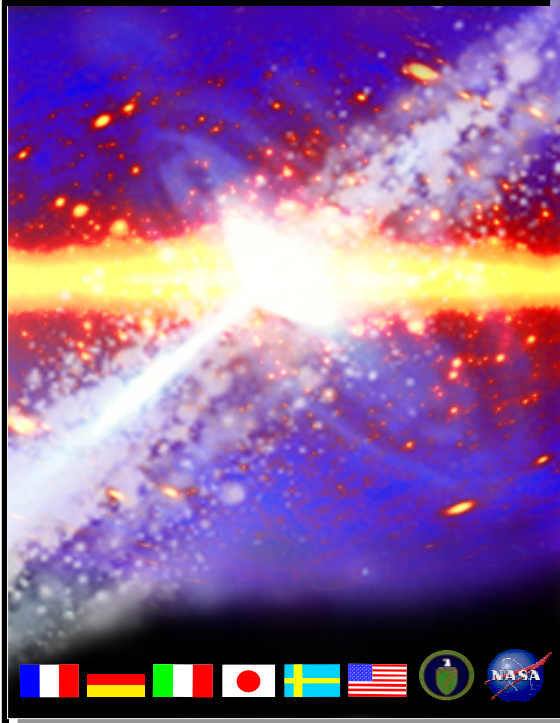

# GLAST Large Area Telescope: AntiCoincidence Detector (ACD) Pre Environmental Review

ACD Team  
NASA Goddard Space Flight Center



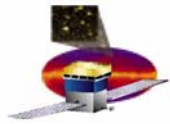

**ACD PER**

# Agenda



**8 June 2005**

<b>SECTION</b>	<b>PRESENTOR</b>	<b>TIME</b>
Introduction	T. Johnson	8:00-8:15
ACD Overview	D. Thompson	8:15-8:45
Requirements & Resource Margins	M. Amato	8:45 – 9:30
Verification Approach & Testing Overview	M. Amato	9:30 – 10:00
Testing – Electrical	M. Amato	10:00 – 10:20
BREAK		10:20 – 10:30
Testing – Mechanical	<i>K. Segal</i>	10:30 – 11:00
Testing – Thermal	<i>C. Peters</i>	11:00 – 11:20
Verification	<i>M. Amato</i>	11:20 – 12:00
LUNCH		12:00 – 1:00
Environmental Testing	<i>C. Coltharp</i>	1:00 – 1:30
Safety	<i>D. Kofeldt</i>	1:30 – 1:45
Risk Management	<i>T. Johnson</i>	1:45 – 2:00
Product Assurance	<i>T. Johnson for J. Lohr</i>	2:00 – 2:30
BREAK		2:30 – 2:45
Programmatics	<i>T. Johnson</i>	2:45 – 3:10
Project Review Activity	<i>T. Johnson</i>	3:10 – 3:15
Closeout	Review Team	3:15 – 4:00

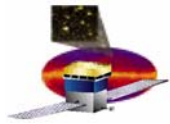

ACD PER

# Scientific Motivation for ACD



8 June 2005

## ***Gamma rays are the most energetic form of light (electromagnetic radiation)***

- *$\gamma$  rays reveal the most powerful, explosive events in the Universe.*
- *Because of their high energy,  $\gamma$  rays cannot be focused or reflected. They act more like particles than waves. High-energy  $\gamma$ -ray telescopes are particle detectors.*
- *In space, charged particle cosmic rays outnumber  $\gamma$  rays by orders of magnitude.*
- *Distinguishing cosmic rays from  $\gamma$  rays is a major challenge for  $\gamma$  ray telescopes.*
- *The ACD is the “first line of defense” in screening out the unwanted cosmic rays.*
- *The job of the ACD is not to stop the particles but rather to detect them.*

### **Two GLAST instruments:**

**LAT: 20 MeV – >300 GeV**

**GBM: 10 keV – 25 MeV**

**Launch: 2007**

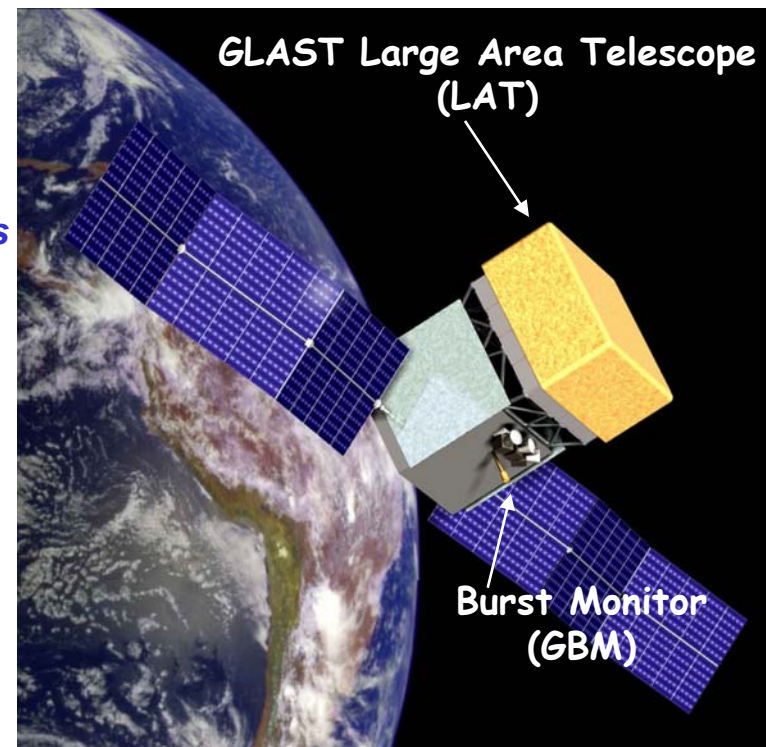

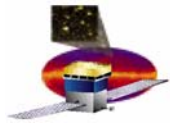

ACD PER

# INSTRUMENT OVERVIEW



8 June 2005

## The Anticoincidence Detector (ACD) is a subassembly of the GLAST Large Area Telescope (LAT)

Tracker

- ◆ Precision Si-strip Tracker (TKR) 18 XY tracking planes. Single-sided silicon strip detectors (228  $\mu\text{m}$  pitch) Measure the photon direction; gamma ID.
- ◆ Hodoscopic CsI Calorimeter (CAL) Array of 1536 CsI(Tl) crystals in 8 layers. Measure the photon energy; image the shower.
- ◆ Segmented Anticoincidence Detector (ACD) 89 plastic scintillator tiles. Reject background of charged cosmic rays; segmentation removes self-veto effects at high energy.
- ◆ Electronics System Includes flexible, robust hardware trigger and software filters.

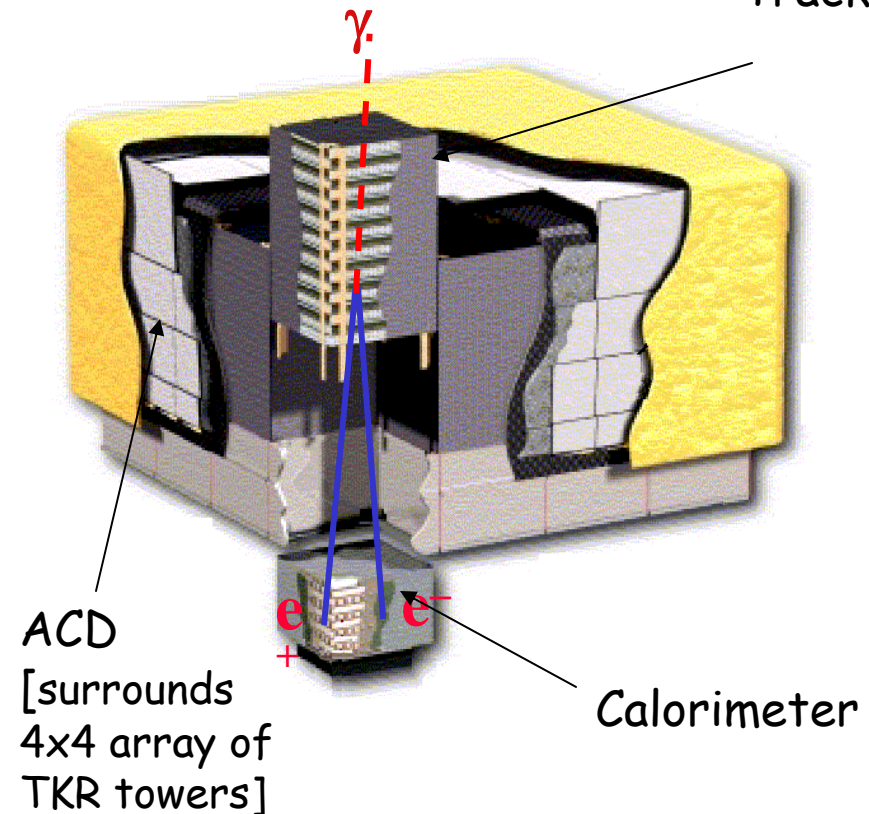

Systems work together to identify and measure the flux of cosmic gamma rays with energy 20 MeV - >300 GeV.

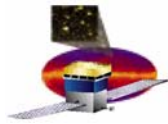

# Charged Particle Detection vs. Backsplash



ACD PER

8 June 2005

Charged particles produce signals lined up in the segmented ACD, TKR, CAL

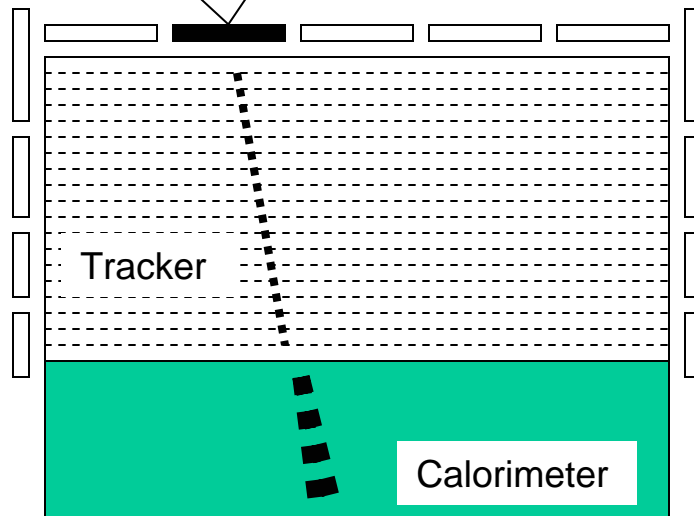

A high-energy gamma ray can produce secondary photons that “splash” out of the CAL and can trigger an ACD tile.

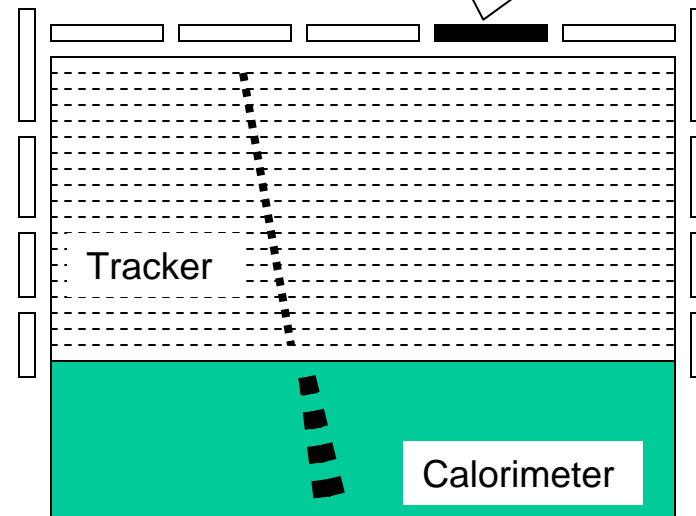

If the ACD were not segmented, we would lose the valuable high-energy gamma rays that produced a back-splash signal. This self-veto reduced the EGRET efficiency at high energies by more than 50%.

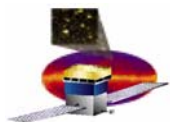

# Level III Key Requirements Summary



ACD PER

8 June 2005

Reference: LAT-SS-00016

Parameter	Requirement	Expected Performance	Verification Method
<b>Detection of Charged Particles</b>	<b><math>\geq 0.9997</math> average detection efficiency over entire area of ACD (less for bottom row of tiles)</b>	<b><math>\geq 0.9997</math> <math>\geq 0.99</math> (bottom tiles)</b>	<b>Test and Analysis</b>
Fast VETO signal	Logic signal 200-1600 nsec after passage of charged particle	200-1600 nsec	Demonstrate
PHA signal	For each phototube, pulse height measurement for each Trigger Acknowledge (TACK) Below 10 MIP, precision of $< 0.02$ MIP or 5% (whichever larger) Above 10 MIP, precision of $< 1$ MIP or 2% (whichever larger)	$< 0.02$ MIP or 5% $< 1$ MIP or 2%	Test and Analysis
<b>False VETO rate - backsplash</b>	<b><math>&lt; 20\%</math> false VETO's due to calorimeter backsplash at 300 GeV</b>	<b><math>&lt; 20\%</math></b>	<b>Test and Analysis</b>
False VETO rate - noise	$< 1\%$ gamma-ray rejection from false VETO's due to electrical noise	$< 1\%$	Analysis
High Threshold (Heavy Nuclei) Detection	Detection of highly-ionized particles (C-N-O or heavier) for calorimeter calibration.	Yes	Analysis
Size	Outside: 1820 x 1820 x 1050 mm 1827 x 1827 for lowest 310mm Inside Grid: 1574 x 1574 x 204.7 mm Inside TKR: 1515.5 x 1515.5 x 650 mm	$< 1800 \times 1800 \times 1025$ at hardpoints $\sim 1820 \times 1820 \times 1050$ at softpoints 1574 x 1574 x 204.7 $> 1515.5 \times 1515.5 \times 650$	Demonstrate
Mass	$< 295$ kg	278 kg	Demonstrate
Power	$< 11.5$ Watts (conditioned)	$< 11.5$ Watts	Demonstrate
Instrument Lifetime	Minimum 5 yrs	$> 5$ yr.	Analysis

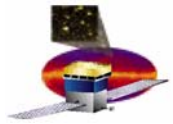

ACD PER

# INSTRUMENT OVERVIEW ACD



8 June 2005

**Tile Shell Assembly  
(TSA)**

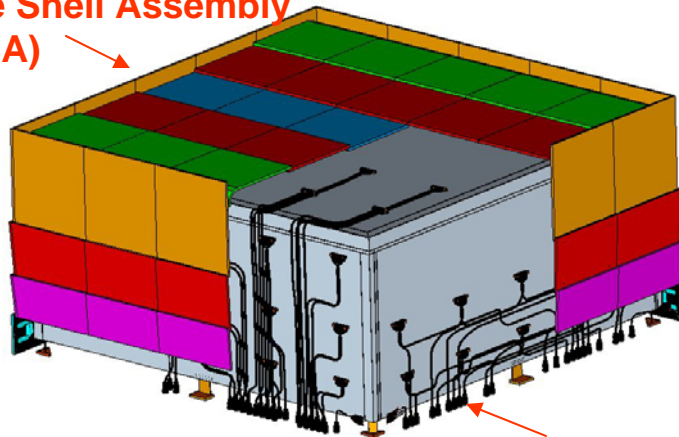

**Base Electronics  
Assembly (BEA)**

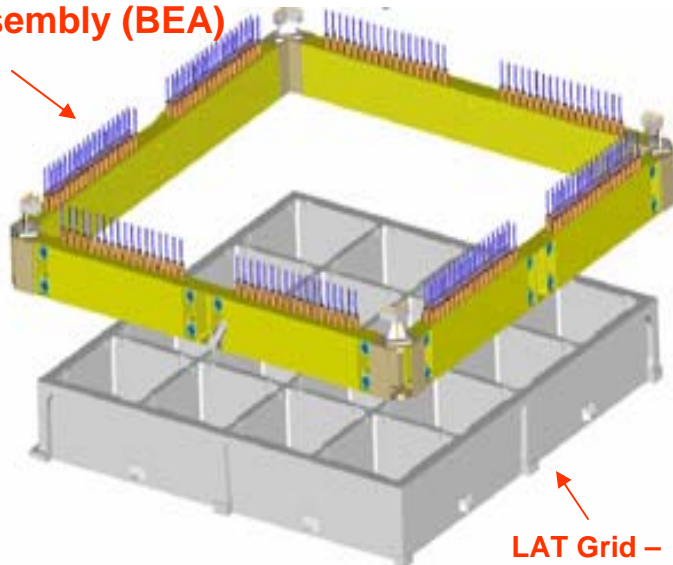

**LAT Grid –  
Mechanical/Thermal  
Interface to LAT**

## ◆ **TILE SHELL ASSEMBLY**

- 89 Plastic scintillator tiles
- Waveshifting fiber light collection (with clear fiber light guides for long runs)
- Two sets of fibers interleaved for each tile
- Tiles overlap in one dimension
- 8 scintillating fiber ribbons cover gaps in other dimension (not shown)
- Supported on self-standing composite shell
- Covered by thermal blanket + micrometeoroid shield (not shown)

## ◆ **BASE ELECTRONICS ASSEMBLY**

- 194 photomultiplier tube sensors (2/tile)
- 12 electronics boards (two sets of 6), each handling up to 18 phototubes. Two High Voltage Bias Supplies on each board.

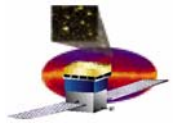

ACD PER

# Instrument Overview TDAs



8 June 2005

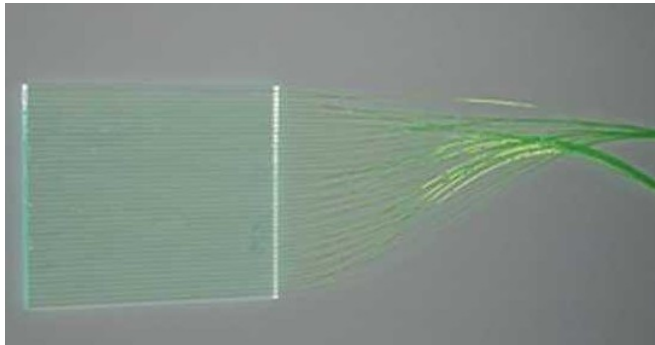

Scintillator Tile/Waveshifting Fibers

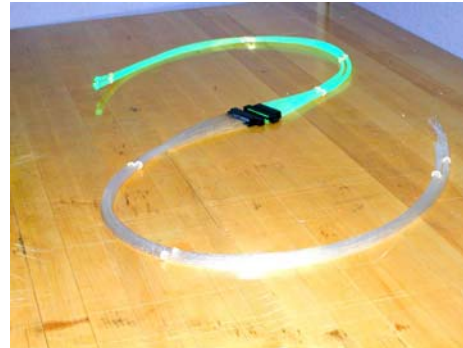

Optical Connector/Clear Fibers



Phototube/Resistor Network



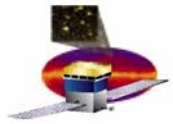

ACD PER

# INSTRUMENT OVERVIEW



8 June 2005

## Electronics Chassis

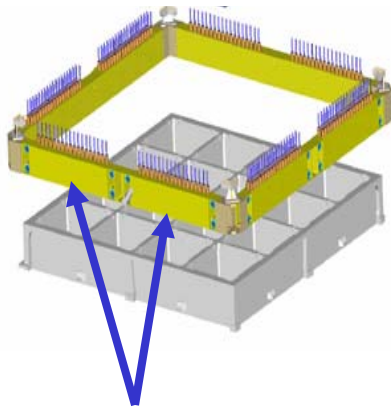

Electronics Chassis (8)  
(4 double and 4 single)

8X  
←



Photomultiplier Tube  
Assembly

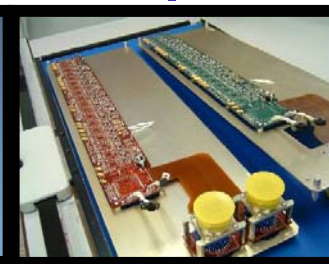

Front End Electronics  
(Free) Boards

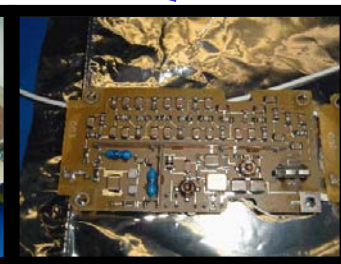

High Voltage  
Bias Supplies  
(HVBS)

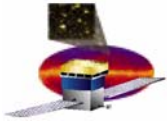

ACD PER

## Design Changes Since CDR



8 June 2005

### ◆ ***Tile Detector Assemblies and Clear Fiber Cables***

- *Redesigned the wave shifting and clear fiber connectors to optimize assembly and light tightening the detectors and fiber cables.*

### ◆ ***Mechanical***

- *The side layers of Kevlar in the Micrometeoroid Shield were increased from 6 layers to 8 layers due to an update to NASA's orbital debris model.*
- *Minor design tweaks on the PMT Housings and fiber bushing caps were made to improve the light-tightness*
- *Modified the mechanical mounting of the Photomultiplier Tubes (PMTs). Changed from a Silicone potted mounting method to thermal compensated mechanical mounted. This design change required a change to the magnetic shielding of the PMTs as well. Design change required to prevent cracking of the PMT glass tubes.*
- *Composite panel aluminum honeycomb grounded*
- *The entire Tile Shell Assembly (with Tile Detector Assemblies) was raised 1mm with respect to the Base Electronics Assembly and the Large Area Telescope interface.*

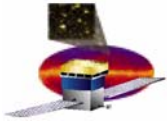

ACD PER

## Design Changes Since CDR



8 June 2005

### ◆ *Electrical*

- *Changed from a 3 independent Printed Circuit Board (PCB) stack for the resistor network to a flex board design. Change made to reduce assembly time and improve reliability.*
- *GARC Parity Bit. The way the GARC implements the GAFE command parity calculation was not consistently reliable so a work around in software was required (e.g., we calculate the command parity in software and bypass the hardware calculation) to resolve the issue.*
- *GARC Look-at-Me circuitry. There are two Look-at-Me circuits, a primary and a secondary, and each needs a clock during power-on reset to initialize properly. On the FREE board it was necessary to cross-strap the incoming differential clock to provide these initial pulses to both sides of the circuitry.*
- *HVBS grounding change. During interface testing between the HVBS and FREE boards a common mode noise issue was found. A capacitor was added to the HVBS and the issue was resolved.*
- *An aluminized Kapton shield was placed between the two FREE boards on the four double row Electronic Chassis. The was done to prevent self induced interference between the two FREE Boards, specifically the GAFE's (analog ASIC).*

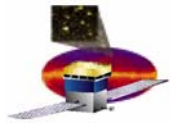

ACD PER

# INSTRUMENT STATUS



8 June 2005

Fully Integrated ACD



Fully Assembled Micrometeoroid Shield

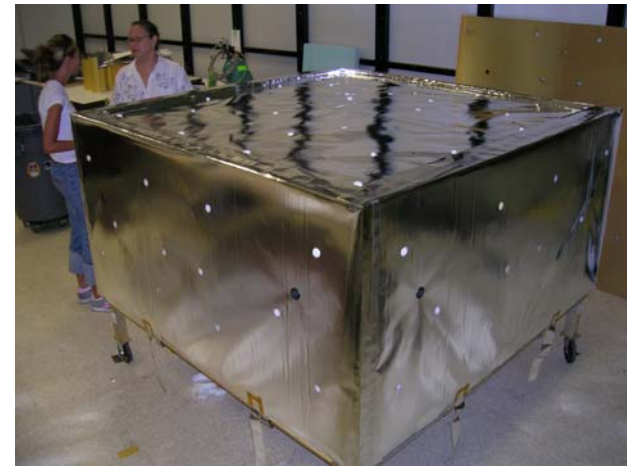

◆ **The ACD is fully integrated**

– *With the exception of the Micrometeoroid Shield and Thermal Blanket, which are both installed later in the test flow.*

– *All 194 detector channels have been connected to their associated electronics and verified to be functional and light tight.*

– *Functional testing has been performed on all eight electronic chassis.*

◆ **Work to be completed prior to beginning environmental testing**

– *Full functional testing on the entire ACD. Each individual electronics chassis has been tested, but the ACD full functional test aborts due to a memory issue with the EGSE Software.*

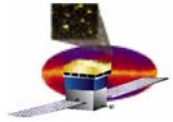

ACD PER

# System Test Planning Test Overview



8 June 2005

# *REQUIREMENTS*

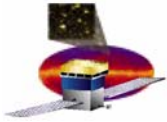

# Level III Key Requirements Summary



ACD PER

8 June 2005

Reference: LAT-SS-00016

Parameter	Requirement	Expected Performance	Verification Method
<b>Detection of Charged Particles</b>	<b><math>\geq 0.9997</math> average detection efficiency over entire area of ACD (less for bottom row of tiles)</b>	<b><math>\geq 0.9997</math> <math>\geq 0.99</math> (bottom tiles)</b>	<b>Test and Analysis</b>
Fast VETO signal	Logic signal 200-1600 nsec after passage of charged particle	200-1600 nsec	Demonstrate
PHA signal	For each phototube, pulse height measurement for each Trigger Acknowledge (TACK) Below 10 MIP, precision of $< 0.02$ MIP or 5% (whichever larger) Above 10 MIP, precision of $< 1$ MIP or 2% (whichever larger)	$< 0.02$ MIP or 5% $< 1$ MIP or 2%	Test and Analysis
<b>False VETO rate - backsplash</b>	<b><math>&lt; 20\%</math> false VETO's due to calorimeter backsplash at 300 GeV</b>	<b><math>&lt; 20\%</math></b>	<b>Test and Analysis</b>
False VETO rate - noise	$< 1\%$ gamma-ray rejection from false VETO's due to electrical noise	$< 1\%$	Analysis
High Threshold (Heavy Nuclei) Detection	Detection of highly-ionized particles (C-N-O or heavier) for calorimeter calibration.	Yes	Analysis
Size	Outside: 1820 x 1820 x 1050 mm 1827 x 1827 for lowest 310mm Inside Grid: 1574 x 1574 x 204.7 mm Inside TKR: 1515.5 x 1515.5 x 650 mm	$< 1800 \times 1800 \times 1025$ at hardpoints $\sim 1820 \times 1820 \times 1050$ at softpoints 1574 x 1574 x 204.7 $> 1515.5 \times 1515.5 \times 650$	Demonstrate
Mass	$< 295$ kg	278 kg	Demonstrate
Power	$< 11.5$ Watts (conditioned)	$< 11.5$ Watts	Demonstrate
Instrument Lifetime	Minimum 5 yrs	$> 5$ yr.	Analysis

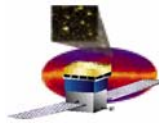

# Key Level III Requirement Changes Since CDR



ACD PER

8 June 2005

Reference: LAT-SS-00016

Parameter	Requirement at CDR	Current Requirement
Detection of Charged Particles	$\geq 0.9997$ average detection efficiency over entire area of ACD (less for bottom row of tiles)	No change since CDR
Fast VETO signal	Logic signal 200-1600 nsec after passage of charged particle	No change since CDR
PHA signal	For each phototube, pulse height measurement for each Trigger Acknowledge (TACK) Below 10 MIP, precision of $< 0.02$ MIP or 5% (whichever larger) Above 10 MIP, precision of $< 1$ MIP or 2% (whichever larger)	No change since CDR
False VETO rate - backsplash	$< 20\%$ false VETO's due to calorimeter backsplash at 300 GeV	No change since CDR
False VETO rate - noise	$< 1\%$ gamma-ray rejection from false VETO's due to electrical noise	No change since CDR
High Threshold (Heavy Nuclei) Detection	Detection of highly-ionized particles (C-N-O or heavier) for calorimeter calibration.	No change since CDR
Size	Outside: 1796 x 1796 x 1050 mm 1806 x 1806 for lowest 310mm Inside Grid: 1574 x 1574 x 204.7 mm Inside TKR: 1515.5 x 1515.5 x 650 mm	Outside: <b>1820 x 1820</b> x 1050 mm <b>1827 x 1827</b> for lowest 310mm Inside Grid: 1574 x 1574 x 204.7 mm Inside TKR: 1515.5 x 1515.5 x 650 mm
Mass	$< 280$ kg	<b><math>&lt; 295</math> kg</b>
Power	$< 31$ Watts (conditioned)	<b><math>&lt; 11.5</math> Watts (conditioned)</b>
Instrument Lifetime	Minimum 5 yrs	No change since CDR

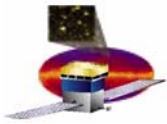

ACD PER

# GLAST Requirements Flow



8 June 2005

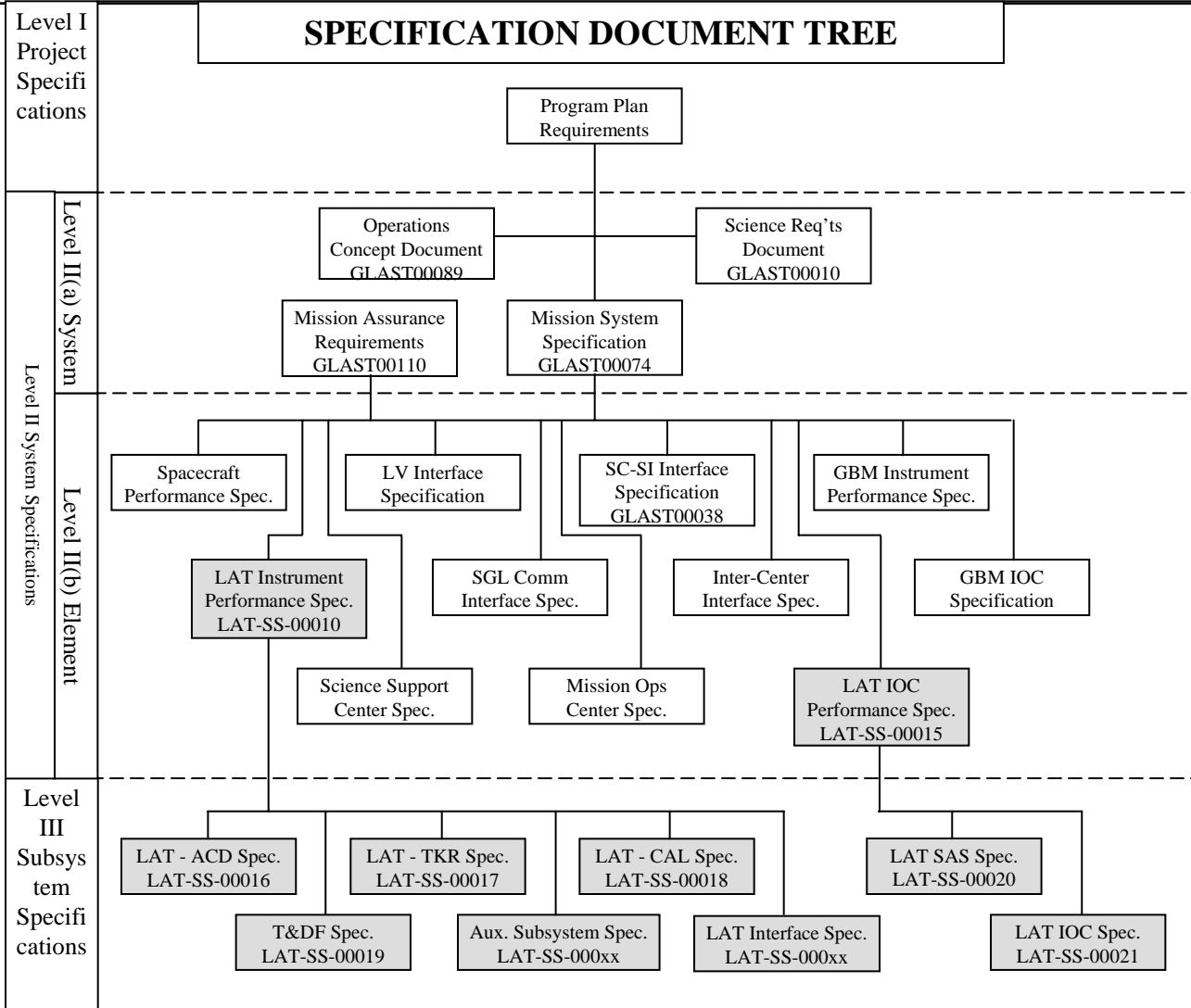

Document under control of the LAT Project
  Document not under control of the LAT Project

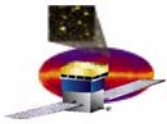

# ACD Requirements Flow/Relationships



ACD PER

8 June 2005

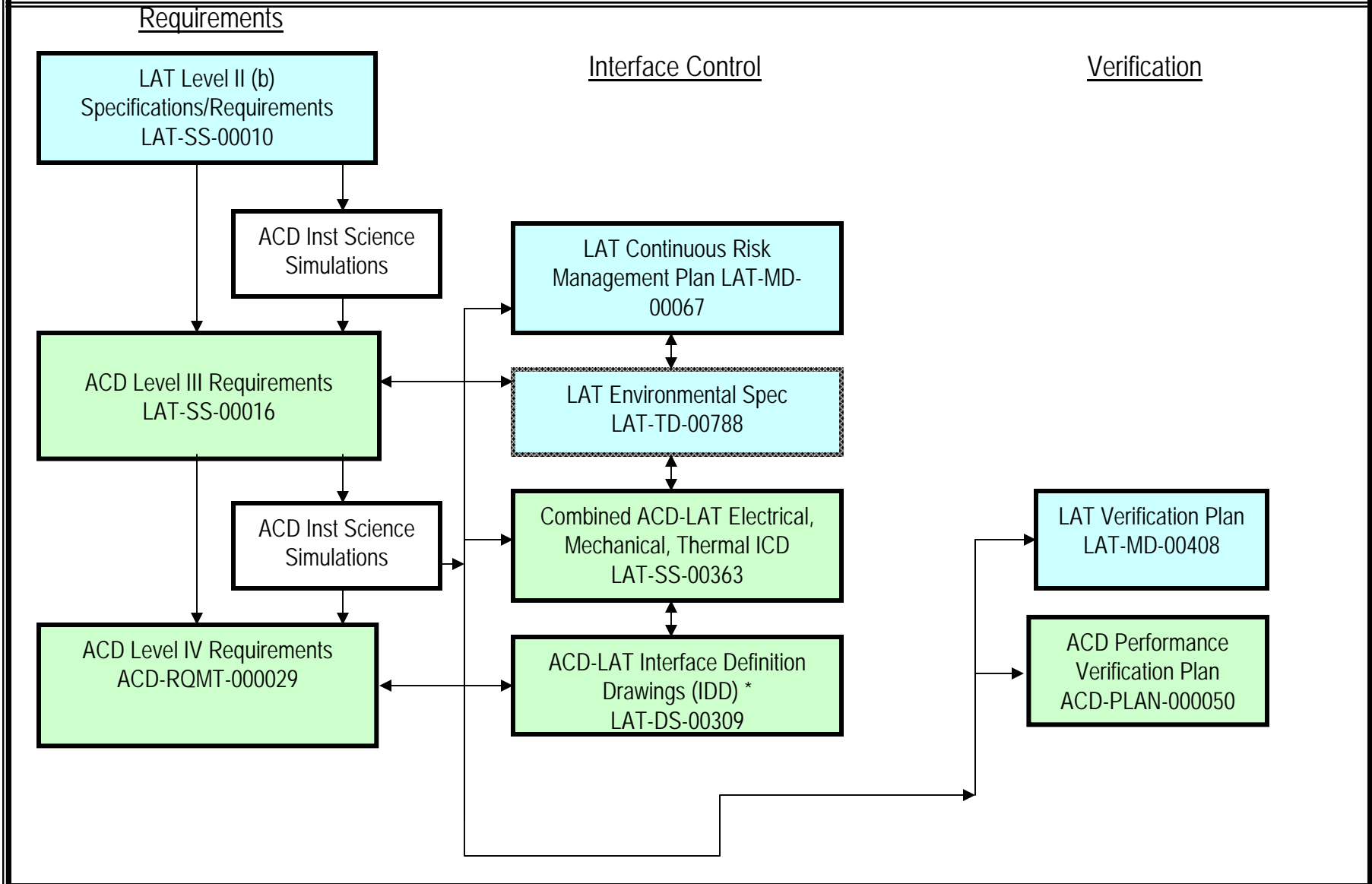

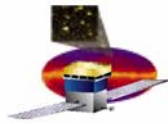

# ACD Requirements Database



ACD PER

8 June 2005

- ACD uses our Requirements Database in DOORS to Track Requirements

ID	LAT ACD Subsystem Level III Requirements, LAT-SS-00016	Parent req Link	Comments	Link	Action Items
	other sources from which they derive are listed in the Requirements 1 table below.				
ACD3-15	<b>5.2 Detection of Charged Particles</b>				
ACD3-16	The ACD shall detect energy deposits with energies of above an adjustable threshold nominally at 0.3 MIP (minimum ionizing particle) (see 5.3 below) and produce VETO signals.				
ACD3-17	<b>5.3 Adjustable Threshold on Detecting Charged Particle</b>				
ACD3-18	The threshold for VETO detection of charged particles shall be adjustable from 0.1 to 2.0 MIP, with a step size of $\leq 0.05$ MIP. (0.1 to 0.6 MIP would have been range if no degradation was expected)				
ACD3-19	<b>5.4 Detection Efficiency</b>				
ACD3-20	The average detection efficiency for minimum ionizing particles shall be at least 0.9997 over the entire area of the ACD (except for the bottom tiles on each side, for which the efficiency shall be at least .99, simulation confirmation of this number is desired at some point).				Latest GAP analysis h been sent to Alex for e simulation update
ACD3-21	<b>5.5 Instrument Coverage</b>				
ACD3-22	The ACD shall cover the top and sides of the LAT tracker down to the top of the CsI. The top of all 4 sides of the ACD scintillator shall be extended upward so as to be at least as high as the highest point in				

ACD Level III Requirement Database (DOORS)

Active Links between Requirements

Active Links between Requirements

ACD-LAT ICD DOORS Database

ACD Level IV Requirement Database (DOORS)

ID	LAT ACD Subsystem Level IV Requirements and Verification Table, LAT-SS-00352	In-links at depth 1	Req	Action item	Req
ACD4-89	<b>5.10.5 HVBS Input Power</b>				
ACD4-90	Each HVBS shall operate from a supply voltage of $28V \pm 1V$ , with possible input ripple of 10 mV (frequency range 50 Hz to 50 MHz). The noise shall be less than 100 mV RMS from DC to 1.0 MHz.	ACD ICD LAT-SS-00363 ACDICD-45			
ACD4-91	<b>5.10.6 HVBS Line and Load Regulation</b>				
ACD4-92	The HVBS output voltage shall be regulated to $\pm 0.5\%$ for all combinations of input voltage and load current. (This produces $\sim 5\%$ change in PMT gain).	ACD Level III Requirements LAT-SS-00016 ACD3-18  ACD Level III Requirements LAT-SS-00016 ACD3-20			
ACD4-93	<b>5.10.7 HVBS Output Ripple</b>				
ACD4-94	The HVBS output voltage ripple shall be compatible with the ACD ASIC design. The HVBS output voltage ripple shall not exceed $\pm 2$ mV p-p over the frequency range 100 Hz to 50 MHz	ACD Level III Requirements LAT-SS-00016 ACD3-16			

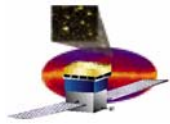

# ACD Requirements



- Some important requirements flow through a science simulation

## ACD Simulation Input Parameters

### Active elements input

- Tile performance
- PMT performance
- Ribbon performance
- Final assembly channel light Through- put

### Passive elements

- Clear fiber performance
- Wave shifting fiber performance
- Fiber connectors performance

### Dead area

- Gap predictions (between tiles and at corners)

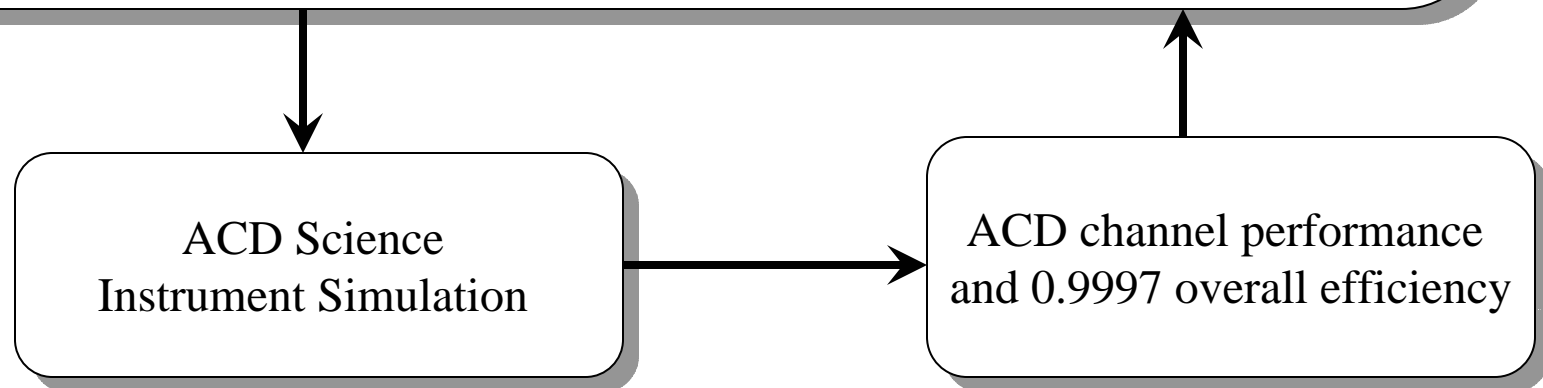

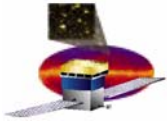

# ACD Requirements – Changes since CDR



ACD PER

8 June 2005

## • CHANGES IN THE LAT ICD

<b>CHANGE REQUEST</b>	<b>DESCRIPTION</b>	<b>REASON</b>
<b>LAT-XR-842-03</b> <b>(Pre-LAT CDR)</b>	<ol style="list-style-type: none"> <li><b>1. Updated CG requirement</b></li> <li><b>2. Connector specifications</b></li> <li><b>3. Flight and test instrumentation (thermal and vibration) specifications</b></li> <li><b>4. Clarification on optical survey and measurement</b></li> <li><b>5. Added helium mitigation plan</b></li> </ol>	<ol style="list-style-type: none"> <li><b>1. Correct known errors</b></li> <li><b>2. Clarification and finalization of requirements.</b></li> <li><b>3. Finalize requirements</b></li> <li><b>4. Finalize requirements</b></li> <li><b>5. Required for PMTs</b></li> </ol>
<b>LAT-XR-774-02</b>	<ol style="list-style-type: none"> <li><b>1. Dead Time Requirement</b></li> <li><b>2. Adjustable High Threshold</b></li> <li><b>3. Low Threshold signal and adjustment</b></li> <li><b>4. Mass allocation</b></li> <li><b>5. Micrometeoroid protection</b></li> </ol>	<ol style="list-style-type: none"> <li><b>1. Clarification</b></li> <li><b>2. Adjusted slightly</b></li> <li><b>3. Deleted. Replaced by zero suppression</b></li> <li><b>4. Increase required</b></li> <li><b>5. Relaxed requirement due to new reliability assessment</b></li> </ol>

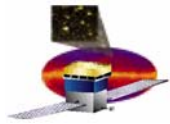

# ACD Requirements – Changes since CDR



ACD PER

8 June 2005

## • CHANGES IN THE LAT ICD

<b>CHANGE REQUEST</b>	<b>DESCRIPTION</b>	<b>REASON</b>
<b>LAT-XR-02469-01</b>	<ol style="list-style-type: none"> <li><b>1. Power allocation reduced</b></li> <li><b>2. Z-axis CG lowered</b></li> <li><b>3. Detector coverage of Trackers</b></li> </ol>	<ol style="list-style-type: none"> <li><b>1. Reduced from 31W to 10.5W average nominal</b></li> <li><b>2. Reduced from 393mm to 330mm</b></li> <li><b>3. Clarified position of detectors with respect to the LAT</b></li> </ol>
<b>LAT-XR-03019-01</b>	<b>Helium limitation requirement</b>	<b>Helium exposure limit increased</b>
<b>LAT-XR-04774-01</b>	<b>BEA survival temperature</b>	<b>Increased from -40C to -30C due to concern about PMT glass failure</b>
<b>LAT-XR-03304-01</b>	<ol style="list-style-type: none"> <li><b>1. Connector locations</b></li> <li><b>2. Added external triggers</b></li> <li><b>3. MLI interface</b></li> <li><b>4. Vent path</b></li> </ol>	<ol style="list-style-type: none"> <li><b>1. Changed location of some connectors</b></li> <li><b>2. Required to test ACD</b></li> <li><b>3. Clarified</b></li> <li><b>4. Clarified</b></li> </ol>

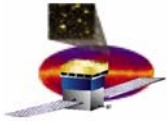

# ACD Requirements – Changes since CDR



ACD PER

8 June 2005

## • CHANGES IN THE LAT ICD

<b>CHANGE REQUEST</b>	<b>DESCRIPTION</b>	<b>REASON</b>
<b>LAT-XR-04696-01</b>	<ol style="list-style-type: none"><li><b>1. ACD mass</b></li><li><b>2. Bottom Tile Detector Assembly location</b></li><li><b>3. Connector location</b></li><li><b>4. GARC Reset</b></li><li><b>5. LVDS termination resistor tolerance</b></li><li><b>6. Cable impedance</b></li><li><b>7. Power supply voltage range</b></li><li><b>8. 28V and 3.3 V power supply current limiting and monitoring requirements added</b></li><li><b>9. Grid surface</b></li></ol>	<ol style="list-style-type: none"><li><b>1. Increase required</b></li><li><b>2. Better definition required.</b></li><li><b>3. Detail added</b></li><li><b>4. Solution for GARC reset issue implemented</b></li><li><b>5. Tolerance was not previously specified</b></li><li><b>6. Requirement added</b></li><li><b>7. Changed requirement from 27-29 V to 24-29 V</b></li><li><b>8. Required for safety and monitoring of ACD</b></li><li><b>9. Changed from alodine to black anodize</b></li></ol>

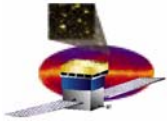

# ACD Requirements – Changes since CDR



ACD PER

8 June 2005

## • CHANGES IN THE LAT ICD

<i>CHANGE REQUEST</i>	<i>DESCRIPTION</i>	<i>REASON</i>
<i>LAT-XR-05240-01-01</i>	<ol style="list-style-type: none"> <li>1. <i>ACD mass</i></li> <li>2. <i>Z-axis CG</i></li> </ol>	<ol style="list-style-type: none"> <li>1. <i>Increase required</i></li> <li>2. <i>Increased from 330mm to 340mm</i></li> </ol>
<i>LAT-XR-06717-01</i>	<ol style="list-style-type: none"> <li>1. <i>Interface cable design</i></li> <li>2. <i>Grounding</i></li> <li>3. <i>Maximum power</i></li> <li>4. <i>MLI grounding</i></li> </ol>	<ol style="list-style-type: none"> <li>1. <i>Updated to reflect current design</i></li> <li>2. <i>Updated FREE board to chassis ground details</i></li> <li>3. <i>Updated maximum power dissipation</i></li> <li>4. <i>Added detail</i></li> </ol>

## • CHANGES IN LAT IDD -

- More defined stay clears, connector locations, hardware
- Change in location of blanket interface – moved up from bottom of ACD
- Addition of ACD blanket ground plate and probable harness run paths
- Insert call out change

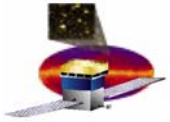

ACD PER



8 June 2005

# RESOURCE MARGINS

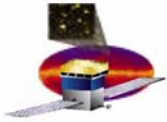

ACD PER

# ACD Technical Budget Summary



8 June 2005

## ***Technical Resources –***

### **◆ ACD Mass**

- ***Allocation***                      ***295 kg***
- ***ACD measurements plus remaining estimates***      ***277.5 kg***
  - *All items (81% of total mass) measured except the MMS and MLI subassemblies (14% , 38.8 Kg of the 278).*
  - *Additional 6% un measured is various minor items, for example bottom tile tie down, minor hardware, one un-measured ribbon, tape, additional clear fiber cable tie downs, instrumentation connector. Most of these items have masses entered by similarity from similar flight items and should be very accurate estimates*
  - *Un-measured items will be measured in assembled ACD lift before calibration tests (any day now)*

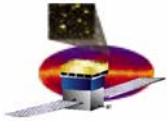

ACD PER

# ACD Technical Budget Summary



8 June 2005

## ***Technical Resources –***

### **◆ ACD Power**

- ***Allocation***                    ***11.5 W nominal, 17 max (reduced from 31 W max conditioned to 10.5 nominal and then recently changed to 11.5 nom, 17 max)***
- ***ACD measurement***    ***11.5W nominal, 16.8 W max in an unlikely but possible scenario.***
  - *Change request number LAT\_XR-06636-01 - Signed off*
  - *Assumptions for nominal and maximum totals from measurements -*
  - *A nominal +28V power of 5.11 Watts shall be required when the temperature is +25C, HVBS voltage output is 1000V, input voltage is +28V and no PMTs have failed.*
  - *A maximum +28V power of 7.06 Watts shall be required for the following configuration:*
    - *six pairs of HVBS (one on and one off) at maximum orbital average temperature (+25C), maximum HVBS supply voltage (1300V), maximum HVBS input voltage (30V) with six failed PMTs,*
    - *plus six pairs of HVBS (one on and one off) at maximum orbital average temperature (+25C), maximum supply voltage (1300V), maximum HVBS input voltage (30V) with no PMT failures.*
  - *The total ACD nominal +3.3V power requirement is 6.23 Watts. The total ACD maximum +3.3V power requirement is 9.77 Watts.*

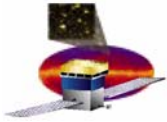

ACD PER

# ACD Technical Budget Summary



8 June 2005

## ***Technical Resources –***

### **◆ Thermal Interface (max dissipation across ACD-LAT interface)**

- ***Dissipation Allocation***                      ***16 W***
- ***Dissipation Analysis***                      ***<14 W***
  - *Not directly measurable with requested de-scope of thermal balance however analysis is very complete and simple with no major assumption uncertainties*
  - *LAT is not sensitive to < 5W? errors in this number*

### **◆ FREQUENCY MARGIN**

- ***All analysis and tests of all subsystems exceed 50 Hz min requirement. Lowest frequency result from tests is ~100 Hz in Electronic Chassis'***

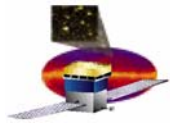

ACD PER



8 June 2005

# VERIFICATION APPROACH

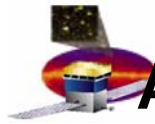

# ACD Requirements and Verification Tracking



ACD PER

8 June 2005

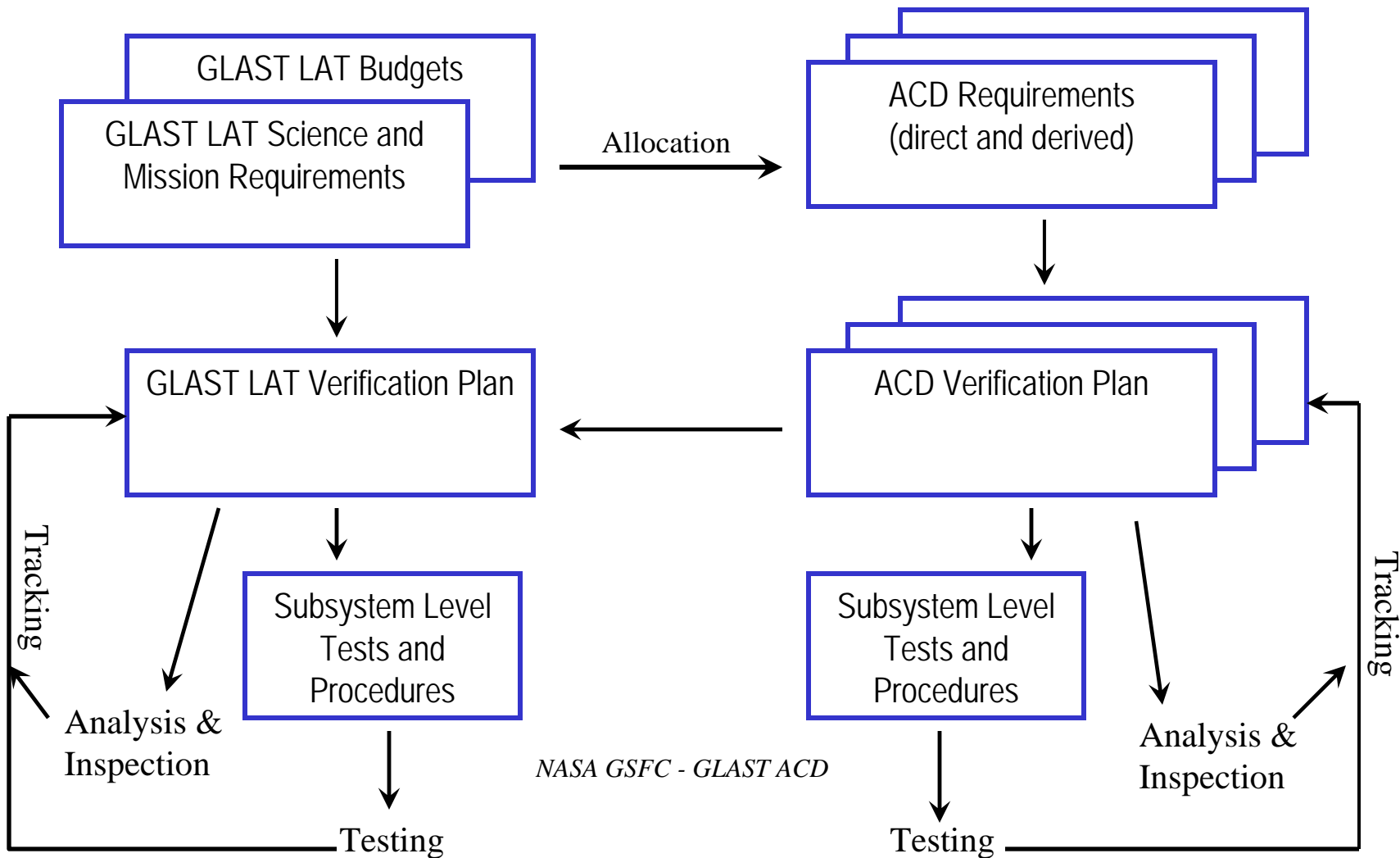

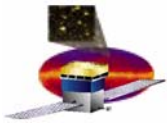

# ACD Verification Database



ACD PER

8 June 2005

- ACD has created a Verification database in DOORS linked to the Requirements Database to Track Verification (Verification Plan - ACD-PLAN-000050)

## ACD Verification Tracking Database

LAT ACD Subsystem Level IV Requirements and Verification Table, LAT-SS-00352	Verification Method	Verification Procedure	Verification Stage/Status	Verification Rationale/Comment	Verification Action	1st time
<b>5.2 Charged Particle Detection</b> The ACD shall produce both fast and slow VETO signals in response to PMT signals resulting from charged particles traversing the ACD tiles and ribbons.	Test	ACD Comprehensive Performance Test (CPT) (ACD-PLAN-000038)	Not Started	Muons test		
<b>5.3 Adjustable Threshold on VETO Detection of Charged Particles</b> The threshold for detecting charged particles shall be adjustable from 0.064 to 1.28 pC (0.1 to 2 MIP), with a step size of $\leq 0.032$ pC (0.05 MIP).	Test	ACD CPT (ACD-PLAN-000038) FREE Functional Test (ACD-TBD-XX)	Not Started	The FREE Functional will characterize the adjustable threshold to the spec step size.  The CPT will test this adjustability with the TCI circuit, however, it currently doesn't have the resolution to fully test this function.		
<b>5.4 False VETO due to Electrical Noise</b> The total ACD false VETO trigger rate due to noise shall be less than 10 kHz (~46Hz per channel) at 0.096 pC (0.15 MIP) threshold (assuming 1 us VETO pulses).	Analysis Test Simulation	ACD CPT (ACD-PLAN-000038)	Development	Set threshold to 0.15 MIP and then reduce HVES output until VETO count rate no longer decreases. The resulting VETO rate is the false trigger rate due to noise.		
<b>5.5 High-Threshold Detection</b> The ACD shall detect pulses due to highly ionizing particles, carbon	Test	ACD CPT (ACD-PLAN-000038)	Development	200 to 1000 MIP will be		

Links between Requirements

ACD Level III and IV Requirements Database

ACD-LAT ICD Requirements and Verification Database

ACD Test Matrix and Allocation Tables

ACD Test Databases

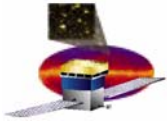

ACD PER



8 June 2005

# TESTING OVERVIEW

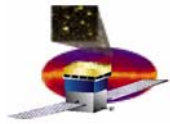

# Test Verification Matrix



ACD PER

8 June 2005

Green rows - Flight, yellow - eng model, white - spares or development

Note : Electronics board components and other small part qualification and testing (i.e Garc, GAFE, HVBS capacitors, Mech fastners etc..) is captured in the ACD parts program plan

Item - major subassemblies in bold	Level of Assembly	Unit Type	Supplier	Test Levels	Test Status	Modal Survey (low level sine survey)	Static Loads	Sine Burst	Sine Vibration	Random Vibration	Mechanical Function/	Optical Performance Testing	Acoustics	Mass Properties	Interface Verif.	EMC/EMI	Magnetics	Screening Process	Aliveness (A) / Functional (F) / Comprehensive (C)	Thermal-Vacuum Cycle (Total of 12 cyc for qual, 4 for acppt)	Thermal Cycle	Thermal Balance	
<b>FULLY INTEGRATED ACD</b>	S	F	GSFC	Prtoflt		X		*	X			X	X	X	X	*			C	4		X	
Tile Shell Assembly	SA	F	GSFC	Acpt		X	X	X	X	X	X	X	X	X	X						6		
Tile Shell Assembly - partial	SA	D	GSFC	Qual		X	X	X	X	X	X	X	X	X	X								
<b>ACD Mechanical Subsystem (no elect Shell)</b>	S	F	GSFC	Qual		X-e		X-e	X-e		X		X	X									
Shell	C	F	TBD	N/A										X									
Shell - partial	P	D	GSFC	Qual			X-b																
<b>Tile Detector Assembly</b>	SA	F	Fermilab	Acpt								X	X	X					A, F				
Tile Detector Assembly	SA	S	Fermilab	Acpt				X	X			X	X	X						12			
Tile Detector Assembly	SA	EM	Fermilab	Qual				X	X	X-m	X	X	X	X					F	6			
Tile Detector Assembly	SA	D	Fermilab	Qual								X	X	X						12			
TDA Tiedown (Flexure)	P	F	GSFC	Prtoflt																			
TDA Tiedown (Flexure)	P	EM	GSFC	Qual			X *	X	X	X-m	X			X									
TDA Tiedown (Flexure)	P	D	GSFC	Qual			X-b																
WSF/Clear Fiber Connector	C	F	GSFC	Acpt								X	X	X					A, F				
WSF/Clear Fiber Connector	C	EM	GSFC	Qual			X	X	X	X-m	X	X	X	X					F				
WSF/Clear Fiber Connector	C	D	GSFC	Qual								X	X	X					A		8		
Base Frame	C	F	GSFC	Qual			X				X			X	X								
Partial BFA & Electronics Chassis	SA	EM	GSFC	Qual			**	**	**	**					X	X			F				
Base Frame - partial	C	D	GSFC	Qual																			
<b>Shield &amp; Thermal Blanket</b>	C	F	GSFC											X								X*	
Shield & Thermal Blanket -see remar	C	EM	GSFC											X									
Shield & Thermal Blanket	C	D	JSC, GSF	Qual																			
<b>Clear fiber cable assembly</b>	SA	F	GSFC	Qual								X							A				
PMT/Fiber Connector	C	F	GSFC									X							A				
PMT/Fiber Connector	C	EM	GSFC	Qual					X	X	X	X							F	6			
PMT/Fiber Connector	C	D	GSFC	Qual								X							F		8		
<b>Base Electronics Assembly</b>	S	F	GSFC	Acpt										X	X				F				
<b>Electronics Chassis</b>	SA	F	GSFC	Acpt		X			X	X-m				X	X				F	4			
Electronics Chassis	SA	S	GSFC	Qual		X		X	X	X-m				X	X				F	12			
Electronics Chassis	SA	EM	GSFC	Qual		X		X	X	X-m				X	X				F	4			
Electronics Chassis	SA	D	GSFC	N/A										X					F				

--Yet to be done  
--Descoped

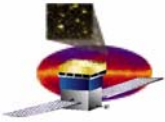

# Test Verification Matrix

ACD PER

8 June 2005

FREE Board (12)	C	F	GSFC	Acpt				0 or 2- see note	0 or 2- see note	0 or 2- see note									X							F		2
FREE Board (4)	C	S	GSFC	Acpt, Qual				0 or 2- see note	0 or 2- see note	0 or 2- see note									X							F		12 - see note
FREE Board (4)	C	EM	GSFC	Qual		1		1	1	1									X	X						F		1 - see note
FREE Board (4)	C	D	GSFC	Qual															X	X						F		
PMT Rail assembly	SA	S	GSFC	Qual																								
PMT Rail assembly	SA	D	GSFC	Qual*																								
PMT Subassembly (194)	P	F	H, GSFC	Acpt		1		1	1	1									X							F	1-see note	1
PMT Subassembly (46)	P	S	H, GSFC	Acpt				X	X	X-m									X							F	12	
PMT Subassembly (30 qual PMTs)	P	EM	H, GSFC	Qual		X		1	X	X-m									X	X	X					F	12	
PMT Subassembly (6)	P	D	H, GSFC	Qual*			X-b		X	X-m									X							F	6	
PMT Subassembly (30)	P	C	H, GSFC	Qual																X						F		X
PMTs (not assembled) (240)	P	F	H	Acpt/qual						X-s									X							X	F-s	
PMTs (not bonded) (10)	P	D	H	Acpt/qual						X-s									X							X	F-s	
PMTs (not bonded) (30)	P	C	H	Acpt						X-s									X							X	F	
Resistor Networks now part of PMT	C	D	GSFC	Acpt															X	X						F		
Power Dist brd	C	F	GSFC	Acpt				1	1	1																F	1-see note	
Power Dist brd	C	S	GSFC	Acpt																						F		
Power Dist brd	C	EM	GSFC	Qual		1		1	1	1																F	1-see note	
HVBS (24)	C	F	GSFC	Acpt				1	1	1																F	2	
HVBS (4)	C	S	GSFC	Acpt, Qual				1 - C see note	1 - C see note	1 - C see note										X						F	1 - C - see note	
HVBS (4)	C	EM	GSFC	Qual		1		1	1	1										X						F	see note	
HVBS (3)	C	D	GSFC	Qual																						F		

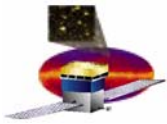

# Top Level Environmental Test Flow (from matrix UPDATE)



ACD PER

8 June 2005

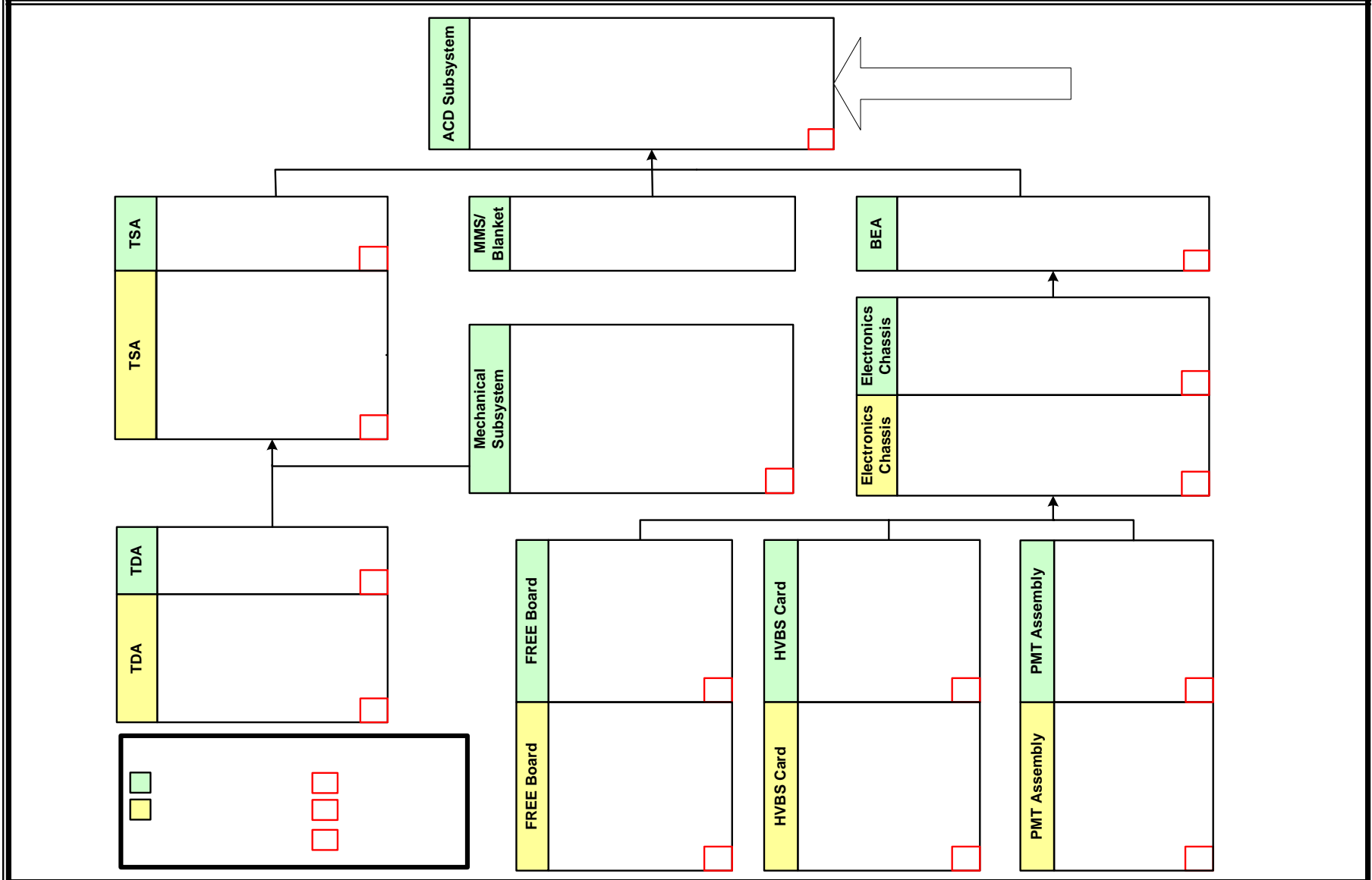

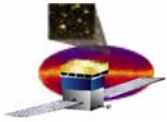

ACD PER



8 June 2005

# TESTING -ELECTRICAL

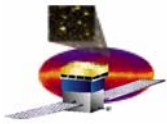

ACD PER

# Electrical Interface



8 June 2005

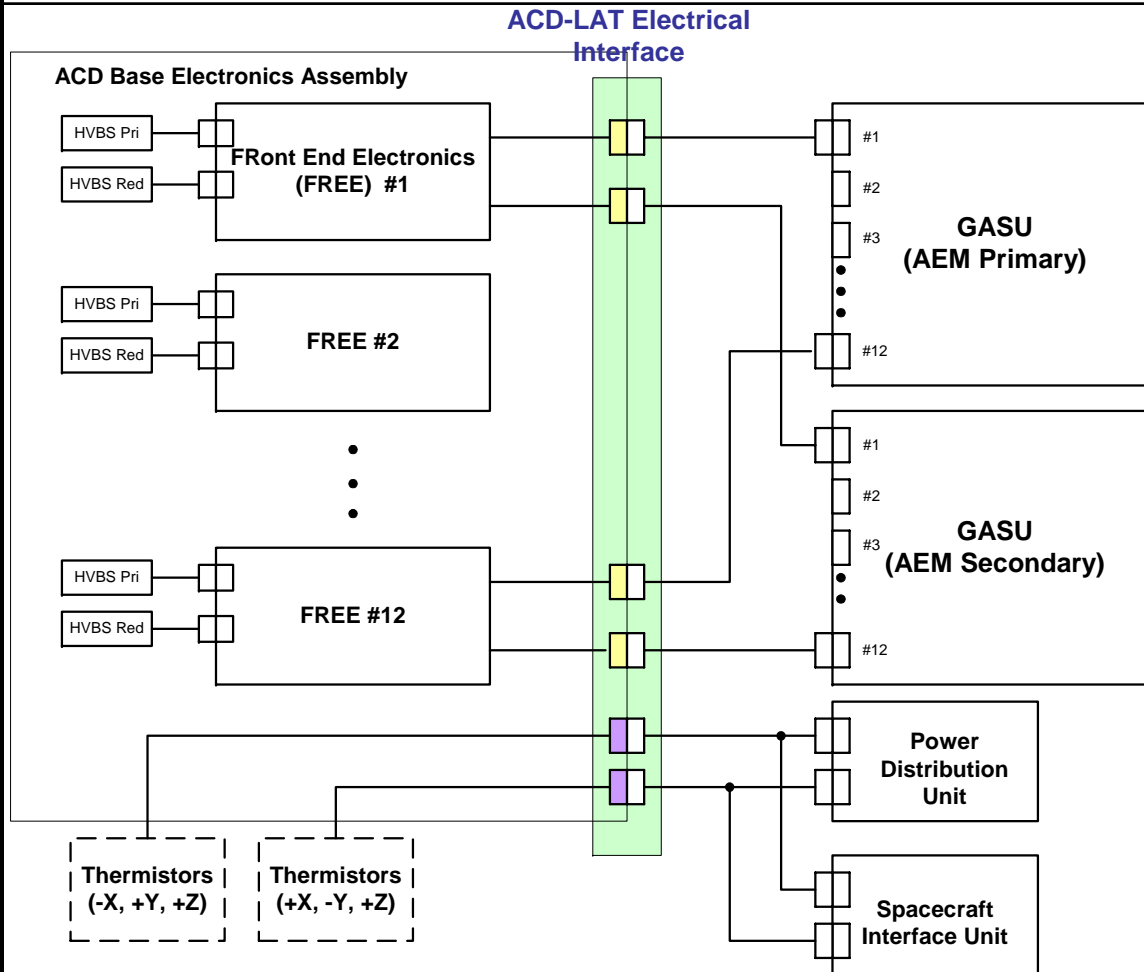

- 24 identical robust circular connectors (38999, series 2) & 2 circular housekeeping connectors (38999, series 2)

- Parts, pin outs, signal def, grounding all defined in ICD

**DATA PRODUCTS**  
*(defined in Reqs. and specified in ICD)*

- Channel specific charged particle VETOs

- VETO hit maps

- Pulse Height Analysis (PHA)

- Diagnostics

- Housekeeping (thermistor output, voltage monitor output, direct to AEM)

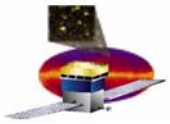

ACD PER

# Electrical System Overview



8 June 2005

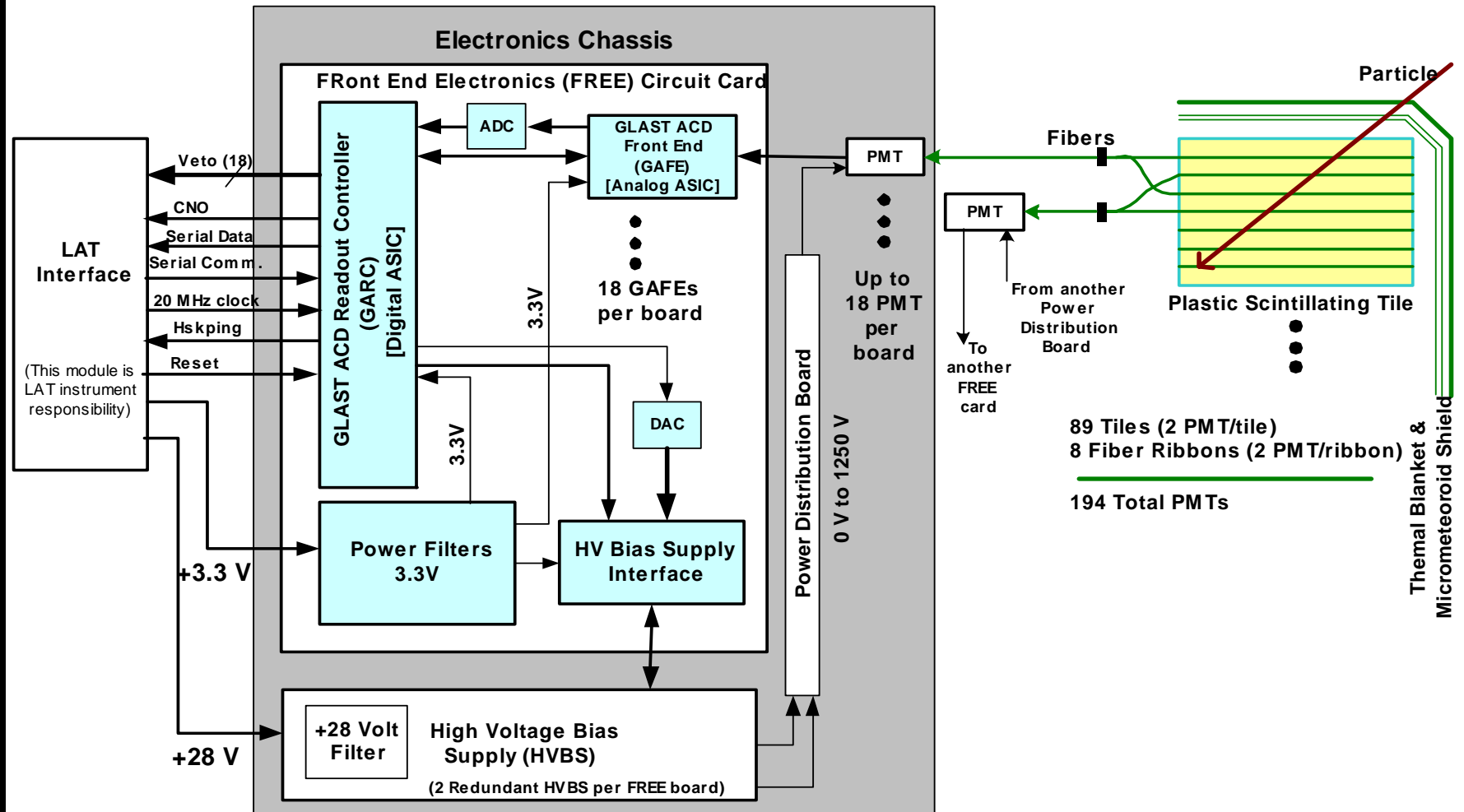

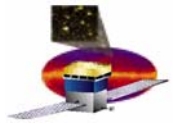

ACD PER

## ASIC Testing



8 June 2005

GARC  
(12)

GAFE  
(194)



ACD ASIC's

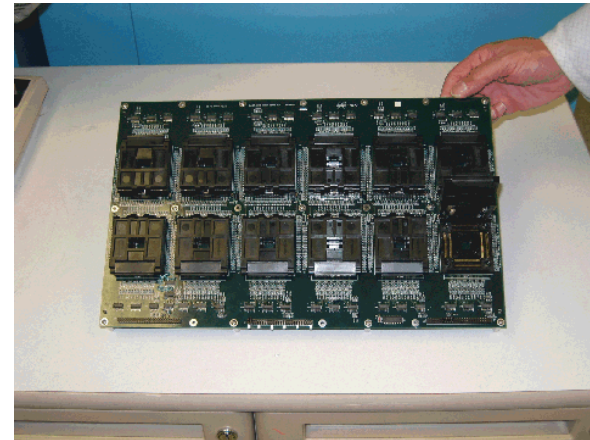

ASIC Test Board

- The ACD Analog (GAFE) and Digital (GARC) ASICs were subjected to a screening and qualification plan as specified in ACD-PLAN-000142. This included electrical and parametric testing, thermal cycling (20 cycles for screening and 200 cycles for qualification), CSAM, HAST for 100 hours at 130°C, life testing for 1000 hours at 125°C<sup>1</sup>, dynamic burn-in for 168 hours at 85°C, and radiation testing (TID and SEU). Following full screening the ASICs were installed onto the FREE boards and subjected to additional testing.
- Other than the deviation provided in note 1 below, all tests were successfully completed and no ASIC failures have occurred on fully screened and qualified parts.

1. The GARC did not fully complete life testing due to repeated test board failures.

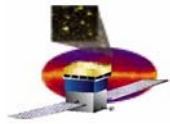

ACD PER

# PMT Testing



8 June 2005

PMT Assembly (1 of 194)



PMT Rail (Dual Row)



	<i>Thermal Vacuum / Corona Test</i>	<i>Aliveness</i>	<i>Post-coat Resistor Network functional</i>	<i>Light Tight</i>	<i>PMT Rail Functional (up to 17 PMTs)</i>
<i>Photomultiplier Tube Assembly – 10 Electrical Qualification Units / 30 Mechanical Qualification Units</i>	<i>ACD-PROC-000260</i>	<i>ACD-PROC-000210</i>	<i>ACD-PROC-000203</i>	<i>ACD-PROC-000210</i>	<i>ACD-PROC-000211</i>
<i>Photomultiplier Tube Assembly – 194 Flight Units + 24 available spares</i>	<i>ACD-PROC-000260</i> <i>10 units</i>	<i>ACD-PROC-000210</i> <i>All units</i>	<i>ACD-PROC-000203</i> <i>All units</i>	<i>ACD-PROC-000210</i> <i>All units</i>	<i>ACD-PROC-000211</i> <i>All units</i>

- 1120 Flight WOA's generated for flight PMT assembly and test – All accounted for.
- Issues encountered and resolved – 1. PMT glass failure, 2. Noise anomaly (6 units total), 3. Lepracon connector failure due to vibration (1 of 250 units).
- All flight units and flight spares have successfully passed all required tests or have been screened out of the flight quantity.

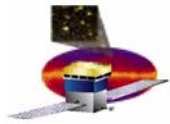

ACD PER

# FREE Testing



8 June 2005

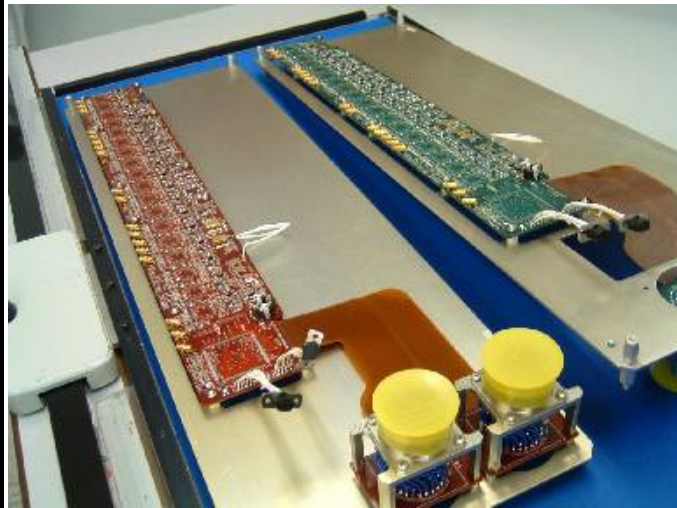

- Issues encountered and resolved – 1. GARC implementation of the the GAFE command parity calculation, 2. Cross-strapped the incoming differential clock to provide initial pulses to both sides of the GARC look at me circuit, 3. Added an additional chassis ground.
- All flight units have successfully passed required tests.

	<i>Comprehensive Performance Test</i>	<i>Post Vibration Functional</i>	<i>Thermal Cycling Functional</i>	<i>Post Coat Short Functional</i>	<i>Post Coat Thermal</i>
<b>FREE Board – 1 Engineering Test Unit</b>	<i>ACD-PROC-000051</i>	<i>ACD-PROC-000051</i>	<i>ACD-PROC-000150</i>	<i>N/A</i>	<i>N/A</i>
<b>FREE Board – 1 Proto-Type Unit</b>	<i>ACD-PROC-000051</i>	<i>ACD-PROC-000145</i>	<i>ACD-PROC-000150</i>	<i>N/A</i>	<i>N/A</i>
<b>FREE Board – 16 Flight Units</b>	<i>ACD-PROC-000051</i>	<i>Performed at higher level</i>	<i>ACD-PROC-000150</i>	<i>ACD-PROC-000148</i>	<i>ACD-PROC-000150</i>

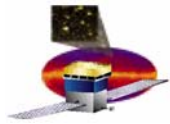

ACD PER

# High Voltage Bias Supply Testing



8 June 2005

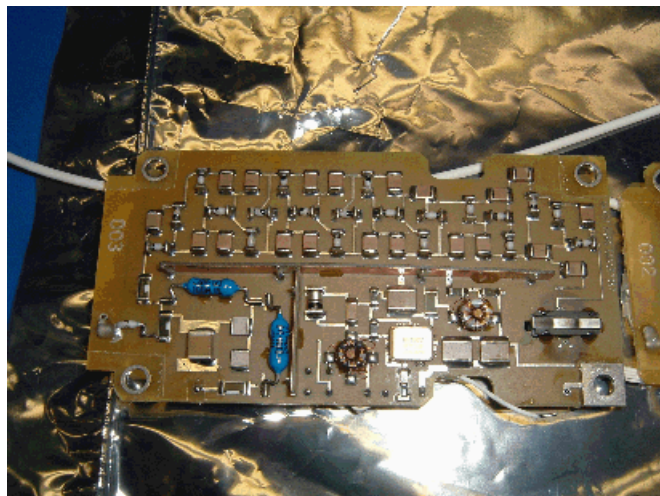

- Issues encountered and resolved – 1. Operating voltage lowered from 27 to 24 Volts, 2. Common mode noise issue which was corrected by adding a capacitor.
- All flight units successfully passed testing and meet all requirements

	<i>Magnetics Test</i>	<i>Functional Test</i>	<i>Vibration</i>	<i>Thermal Vacuum Cycle</i>
<b><i>HVBS – One Qualification Unit</i></b>	<i>ACD-PROC-000176</i>	<i>ACD-PROC-00064</i>	<i>ACD-PROC-000135</i>	<i>ACD-PROC-00064</i>
<b><i>HVBS – 3 Engineering Test Units (1 delivered to LAT)</i></b>	<i>ACD-PROC-000176</i>	<i>ACD-PROC-00064</i>	<i>Performed at next level of assembly</i>	<i>ACD-PROC-00064</i>
<b><i>HVBS – 30 Flight Units (24 used, 6 spare)</i></b>	<i>ACD-PROC-000176</i>	<i>ACD-PROC-00064</i>	<i>Performed at next level of assembly</i>	<i>ACD-PROC-00064</i>

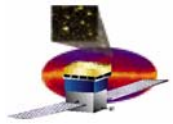

ACD PER

# Electronics Chassis Testing



8 June 2005

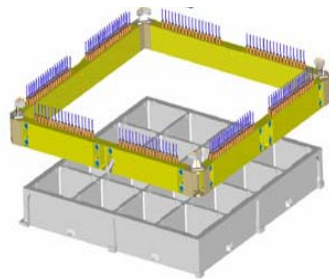

Base Electronics Assembly (1)

8X  
←



Electronics Chassis (8) (4 double + 4 single)

<i>Electronics Chassis</i>	<i>Chassis I&amp;T Functional</i>	<i>Light Pulsar Testing (GSFC EGSE)</i>	<i>Full Functional (with GASU)</i>	<i>Vibration (with GASU)</i>	<i>Thermal Vac (4 cycles)</i>
<i>Qual/ Flight Spare</i>	<i>PROC-000164</i>	<i>PROC-000164</i>	<i>PROC-000279</i>	<i>PROC-000279</i>	<i>PROC-000279</i>
<i>#1 (1L-single)</i>	<i>PROC-000164</i>	<i>PROC-000164</i>	<i>PROC-000222</i>	<i>PROC-000222</i>	<i>PROC-000222</i>
<i>#2 (3L-single)</i>	<i>PROC-000164</i>	<i>PROC-000164</i>	<i>PROC-000222</i>	<i>PROC-000222</i>	<i>PROC-000222</i>
<i>#3 (2L-double)</i>	<i>PROC-000164</i>	<i>PROC-000164</i>	<i>PROC-000222</i>	<i>PROC-000222</i>	<i>PROC-000222</i>
<i>#4 (4L-double)</i>	<i>PROC-000164</i>	<i>PROC-000164</i>	<i>PROC-000222</i>	<i>PROC-000222</i>	<i>PROC-000222</i>
<i>#5 (4R-double)</i>	<i>PROC-000164</i>	<i>PROC-000164</i>	<i>PROC-000222</i>	<i>PROC-000222</i>	<i>PROC-000222</i>
<i>#6 (1R-single)</i>	<i>PROC-000164</i>	<i>PROC-000164</i>	<i>PROC-000222</i>	<i>PROC-000222</i>	<i>Descoped</i>
<i>#7 (3R-single)</i>	<i>PROC-000164</i>	<i>PROC-000164</i>	<i>PROC-000222</i>	<i>PROC-000222</i>	<i>PROC-000222</i>
<i>#8 (2R-double)</i>	<i>PROC-000164</i>	<i>PROC-000164</i>	<i>PROC-000222</i>	<i>PROC-000222</i>	<i>PROC-000222</i>

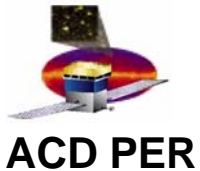

# System Test Planning

## Electrical Tests Issues & Resolution



8 June 2005

### ◆ *Summary of electrical test issues and resolution*

- *FREE Grounding – changed ground*
- *FREE Cross talk – installed small noise shield*
- *GARC look at me - Cross-strapped (i.e white wire repair) the incoming differential clock to provide initial pulses to both sides of the circuit.*
- *GARC Parity Bit – Corrected by software.*
- *HVBS Common Mode Noise – installed additional capacitor*
- *PMT Glass Issue – Zero PMTs have experienced a failure in the updated mechanical mount.*
- *PMT Noise Anomaly – Extensive statistical life testing and root cause analysis, see noise report ACD-RPT-000355*
- *PMT signal cable connector vibration failure – flight heritage part known to be sensitive to workmanship loads. Only 1 of over 250 failed in vibration which is a more rigorous vibration than they will see again in testing or launch*

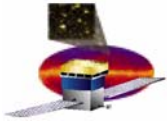

ACD PER

## ELECTRICAL TESTING SUMMARY



8 June 2005

- ◆ ***All flight Photomultiplier Tube (PMT) Assemblies, High Voltage Bias Supplies (HVBS), and Front End Electronic (FREE) Boards successfully completed performance and functional testing.***
- ◆ ***All fabrication, assembly, testing, and integration of all flight electronics was performed using approved and configuration controlled documentation.***
- ◆ ***Final electrical functional testing of all eight Electronic Chassis's has been successfully performed using two independently developed EGSE Test Stands (one GSFC developed and one LAT developed).***
- ◆ ***All eight Electronics Chassis have been vibration tested and seven of the eight have been thermal vacuum tested.***
- ◆ ***All eight Electronic Chassis are integrated to the ACD, have been functionally tested, and all 194 detector channels have been connected and verified to be operational and light tight.***

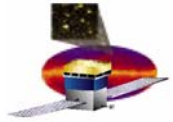

ACD PER

# Environmental Testing Overview



8 June 2005

# TESTING - EMI

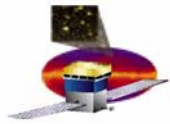

ACD PER

# EMI Testing Overview



8 June 2005

- **The ACD Qualification Chassis underwent EMI/EMC testing at the GSFC test facility on Nov. 17 – Dec. 9, 2004**
- **Due to some apparent exceedances, a flight chassis was used for retesting on April 18-19, 2005, also at GSFC**
- **The ACD chassis passed all tests after copper tape was added to the bottom seam of the chassis cover.**
- **Common Mode Conducted Susceptibility, using the CS114 test method, was successfully performed on June 6**
- **A waiver was requested and approved to exempt the full ACD from EMI/EMC testing, because the full ACD is the same design electrically as the individual chassis.**
  - **Extensive EMI testing done on chassis**
  - **Little else would be learned from a very expensive and long ACD level EMI test using non-flight-like electrical interface.**

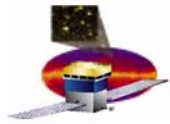

ACD PER

# EMI Testing Results



8 June 2005

## Susceptibility

- RS101, RS103 – no susceptibility
- CS102, CS06 – no susceptibility
- CS114 – no susceptibility

## Emissions – both horizontal and vertical polarizations

- CE102, CECM – no emissions above limit
- RE101, RE102 – no emissions above limit, after subtracting emissions from EGSE.

**EMI Test Reports – ManTech 22-07-1281, 22-07-1298**

**CS114 Test Report is forthcoming**

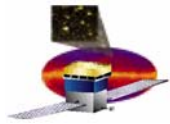

ACD PER



8 June 2005

# ***ACD MECHANICAL*** **Pre-Environmental (Test Readiness)** **Review**

*June 8, 2005*

*ACD Mechanical Team*

*Ken Segal / Code 543, ACD Lead Mechanical Engineer*

*Ryan Simmons / Code 542, ACD Lead Mechanical Analyst*

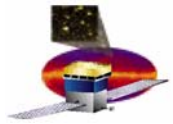

ACD PER

# ACD Mechanical PER Presentation Outline



8 June 2005

- ◆ **Introduction**
  - *Hardware Overview*
- ◆ **Mechanical Verification Testing**
  - **Subsystem Verification Tests Complete**
    - *Mechanical Structure*
    - *Detectors*
    - *Electronic Chassis*
  - **System Verification Tests Planned**
    - *Test Flow*
    - *Pre -Test Analysis Test Prep Status*
  - **Mass Properties**
- ◆ **Conclusions**

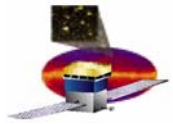

ACD PER

# ACD Hardware Overview



8 June 2005

## ◆ *Large Area Telescope (LAT)*

- Primary GLAST Instrument

- ACD is a Subsystem of the LAT

- Managed by Stanford Linear Accelerator Center (SLAC)

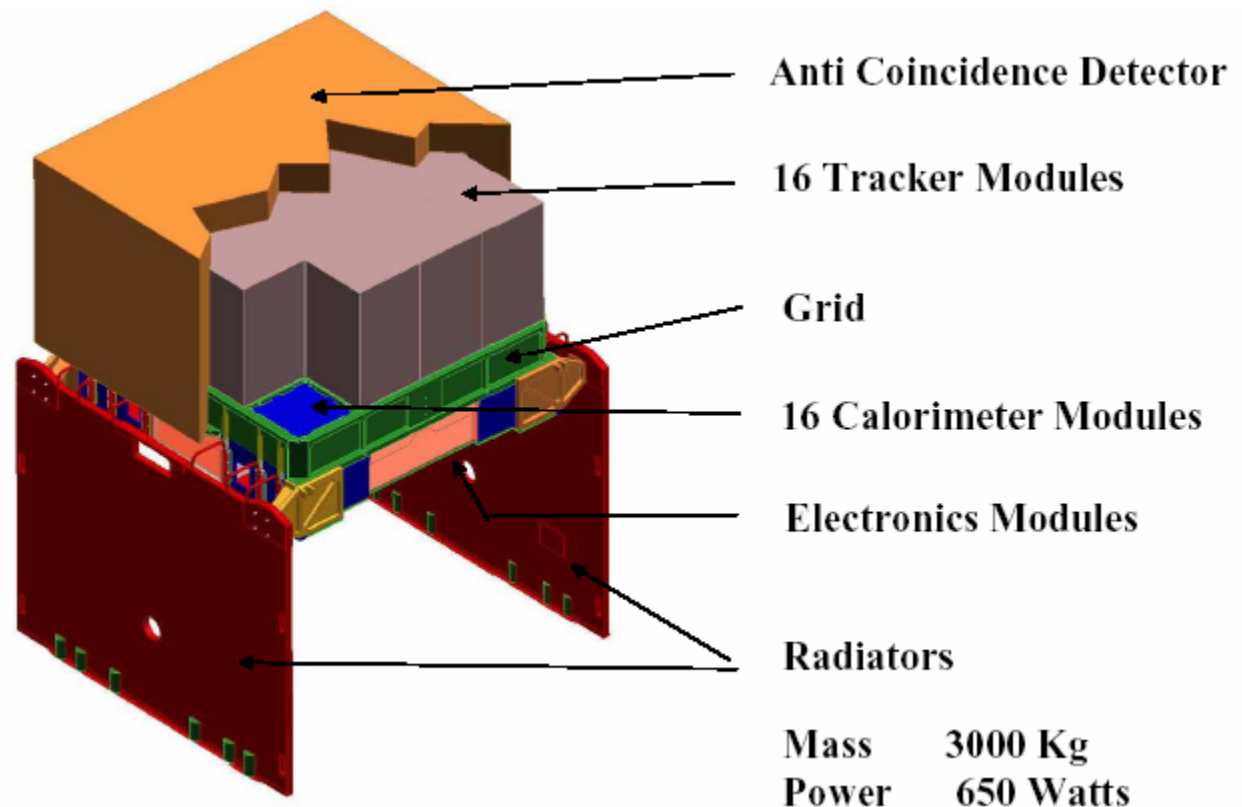

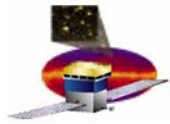

# ACD Hardware Overview



## *Anti-Coincidence Detector (ACD)*

- ◆ *Tile Shell Assembly*
- ◆ *Base Electronics Assembly*
  - *Base Frame Assembly (BFA) is the load bearing structural element*
  - *Carries 8 electronics chassis assemblies*
  - *Electrical Interface to LAT*
  - *Structural Interface to LAT*
- ◆ *Micrometeoroid Shield / Thermal Blanket (MMS /TB)*
  - *Not Shown*
  - *Provides LAT protection from micrometeoroids and thermal control*

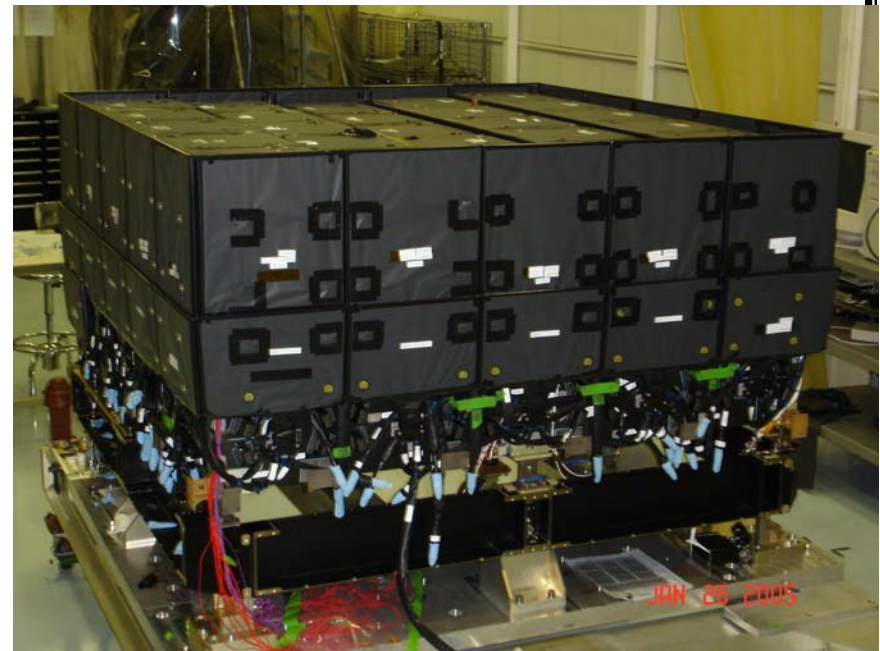

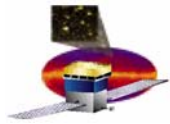

ACD PER

# ACD Hardware Overview



8 June 2005

## *Tile Shell Assembly (TSA)*

- ◆ *Mounts 89 Tiles Detector Assemblies (TDAs)*
- ◆ *Mounts 8 Ribbon Detectors*
- ◆ *Mounts 65 Optically Transmissive Cables*
- ◆ *Shell Assembly*
  - *5 Composite Honeycomb Panels*
  - *340 Composite Tile Flexures*
  - *24 Metallic Tile Flexures*
- ◆ *8 Shell Flexures that interconnect the TSA to the Base Frame Assembly (BFA)*

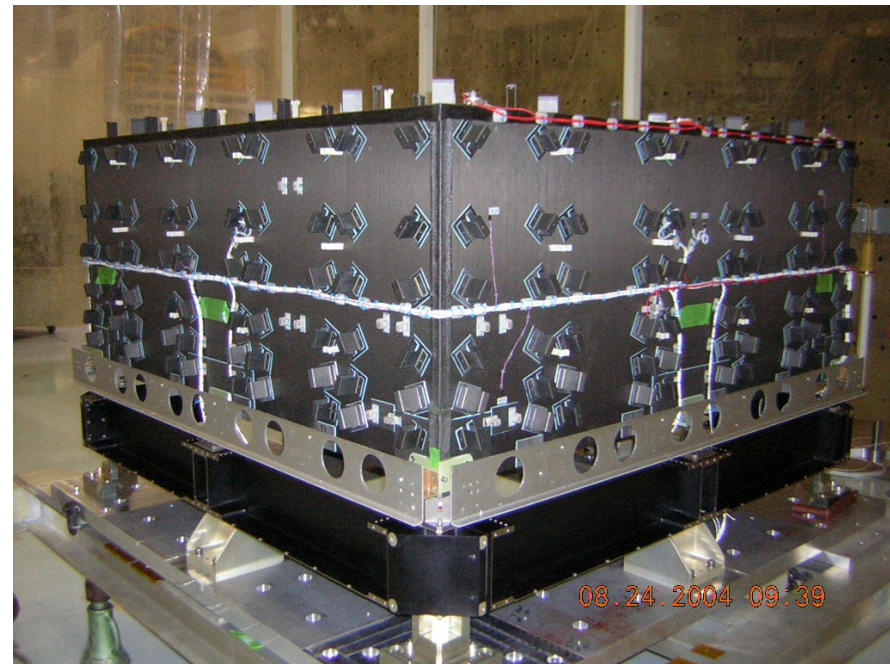

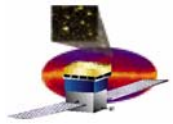

ACD PER

# ACD Hardware Overview



8 June 2005

## ***BASE FRAME ASSEMBLY***

*Main Structural Element of the Base  
Electronics Assembly (BEA)*

### **COMPOSED OF**

- ◆ *4 Identical machined aluminum (6061-T6) parts bolted and pinned together*

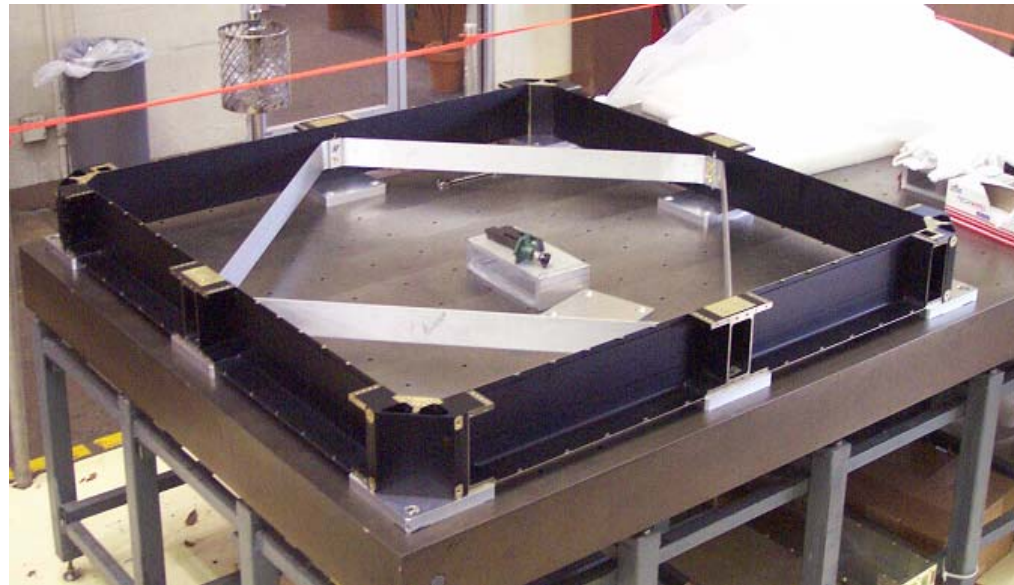

### **PROVISIONS FOR**

- ◆ *ACD-LAT Structural Interfaces*
- ◆ *8 Electronics Chassis Assemblies*

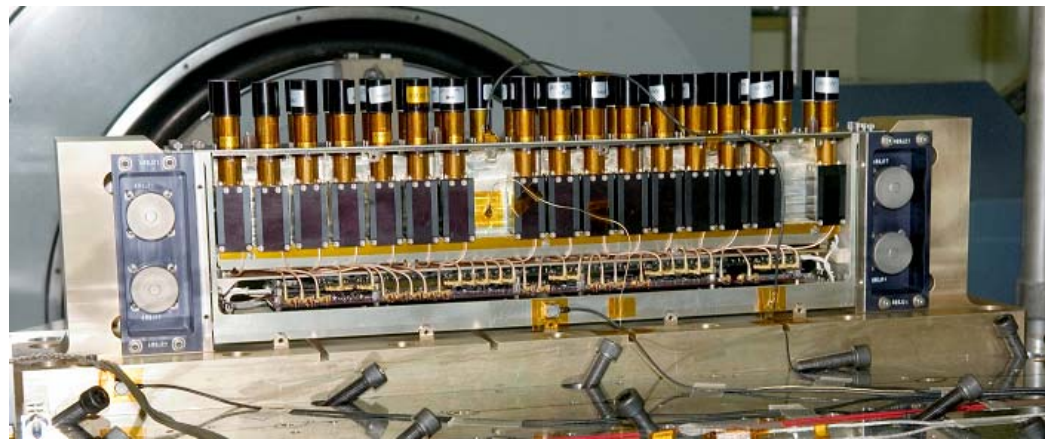

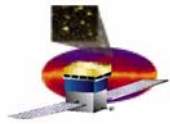

ACD PER

# ACD Mechanical Subsystem Qualifications Performed (May 2004)



8 June 2005

## ◆ *Sine Burst, Swept Sine Tests*

### – *TSA*

- *Shell Panels*
- *Tile Flexures*
- *Shell Inserts*
- *MMS Standoffs*

### – *BFA*

- *LAT-ACD Corner Interface*
- *Shell Flexure Interface*
- *BFA Interfaces for BEA  
Electronics Chassis*

### – *Shell Flexures*

## ◆ *Static Pull Tests*

### – *BFA*

- *LAT-ACD Mid-Span  
Interface*
- *BFA Interface for ACD Lift*

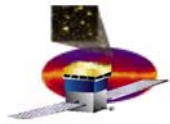

ACD PER

# Hardware Qualifications Performed



8 June 2005

## ◆ *Vibration Testing Summary*

- *Tests Successfully Completed May 2004*
- *Strength qualified through sine burst testing*
  - *Due to the weight being less than fully allocated, higher sine burst levels were required to strength qualify the structure*
  - *X = 8.8g (9.0g achieved)*
  - *Y = 8.8g (8.9g achieved)*
  - *Z = 10.0g (10.1g achieved)*
- *Minimum frequencies*
  - *50hz Requirement*
  - *Frequency Measured*
    - *X = 75Hz*
    - *Y = 74Hz*
    - *Z = 74Hz*

## ◆ *Test Documentation*

- *Plan*
  - *ACD-PLAN-000187 “ACD Structural Qualification Vibration Test Plan”*
- *WOA*
  - *ACD-WOA-00946*
- *PRs*
  - *ACD-000-946-001 Closed*
- *Test Report*
  - *ACD-RPT-000219 “ACD STRUCTURAL QUALIFICATION POST-TEST REPORT”*



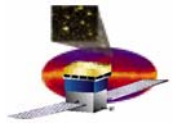

ACD PER

# Hardware Qualifications Performed



8 June 2005

## ◆ *Static Pull Tests*

- *BFA was pull-tested for strength qualification*
- *LAT-ACD Mid-Span Interface*
- *Adequate force could not be achieved during sine burst testing*

## ◆ *Test Documentation*

- *Plans*
  - *ACD-PLAN-000202*
- *WOA*
- *No PRs*
- *Test Report*
  - *ACD-RPT-000219 “ACD STRUCTURAL QUALIFICATION POST-TEST REPORT”*

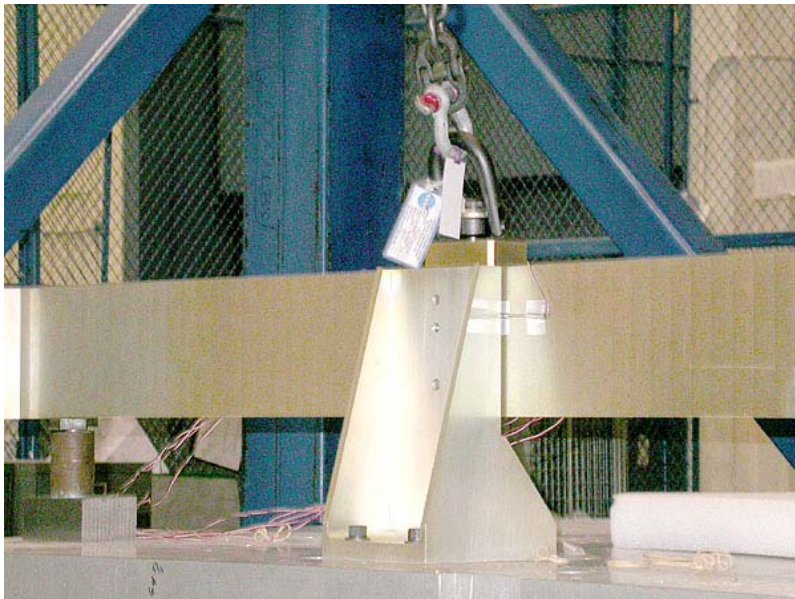

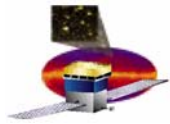

ACD PER



8 June 2005

# ◆ ***ELECTRONIC COMPONENT QUALIFICATION TESTS PERFORMED***

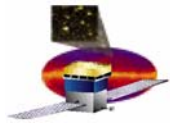

ACD PER

# Electronics Qualification Tests



8 June 2005

## ◆ **Electronic Component Assemblies**

### – **FREE**

- TEST PLAN # ACD-PROC-000145
- WOA 00007

### – **HVBS**

- TEST PLAN # ACD-PROC-000135
- WOA 00002

### – **PMTs**

- TEST PLAN # ACD-PROC-000199
- WOAs *too numerous to list*

◆ **All Assemblies Tested with no mechanical problems recorded**

◆ **All flight hardware fully tested to qualification levels next level of assembly**

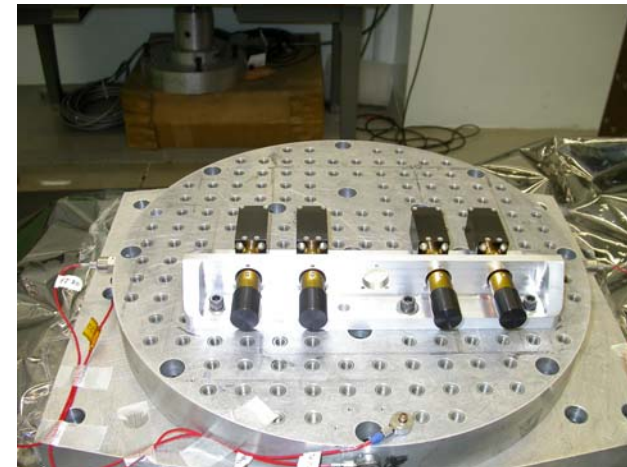
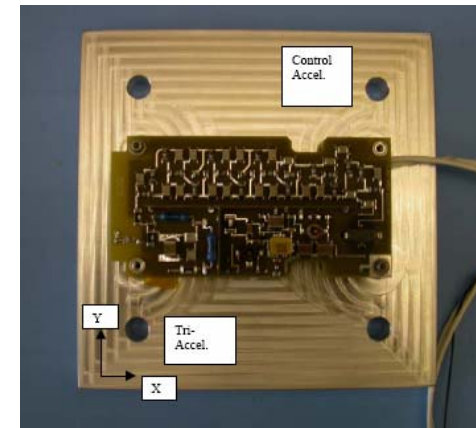

# Electronics Chassis Assembly Qualification / Acceptance Tests

◆ *Electronic Chassis Assemblies*

- *Engineering Unit*
- *Qualification Unit*
- *Flight Unit Acceptance*

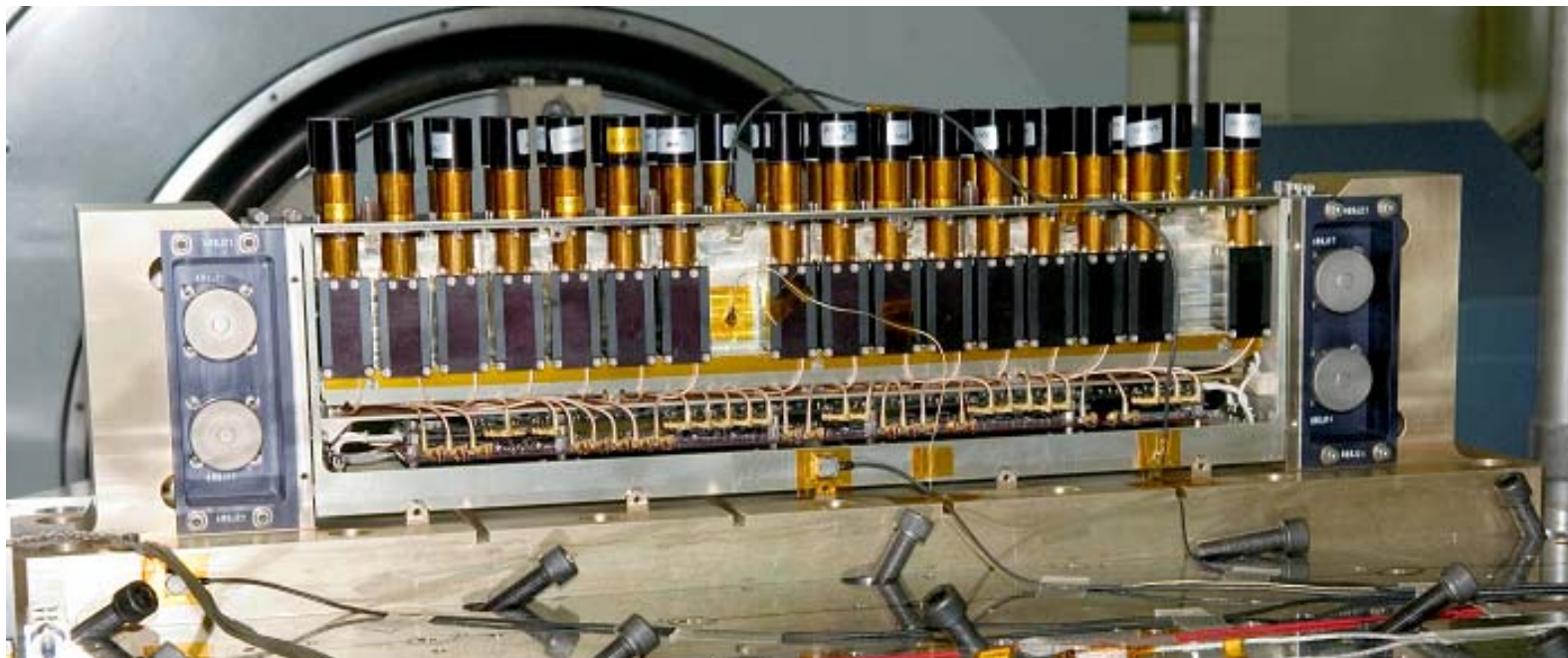

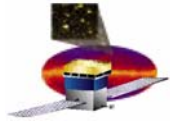

ACD PER

# Electronics Chassis Assembly Qualification / Acceptance Tests



8 June 2005

- ◆ **Chassis flight Acceptance Test**
  - **Flight Chassis Vibe**
    - *Tested to Acceptance Levels for Workmanship*
    - *ACD-PLAN-000161, ACD Electronic Chassis Vibration Test Plan*
  
  - **All Test Completed at GSFC between January 2005 and May 2005**
    - *ACD Flight Electronic Chassis 1L Acceptance Vibration Test Reports*
      - *1L Test Report ACD-RPT-000337*
      - *1R Test Report ACD-RPT-000338*
      - *2L Test Report ACD-RPT-000339*
      - *2R Test Report ACD-RPT-000340*
      - *3L Test Report ACD-RPT-000341*
      - *3R Test Report ACD-RPT-000342*
      - *4L Test Report ACD-RPT-000343*
      - *4R Test Report ACD-RPT-000344*
  
- ◆ **Each Chassis Measured a ~10 % Frequency Shift in the X-Axis Random Vibration Test**

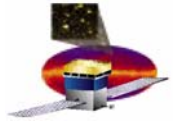

ACD PER

# Component Tests Performed Vibration and Acoustics Tests



8 June 2005

## ◆ *Flight Chassis Frequency Shift Anomaly*

- *Each Chassis Measured a X-axis frequency shift of about 10% after X-axis random vibration testing*
  - *Root Cause -Split PMT Rail Design*
    - *Root Cause Verified By Analyses*
    - *Inspections Show no structural damage*
  - *No Corrective Action Required*
    - *Subjected a chassis to repeated random vibrations and found the frequency shift leveled off.*
  - *Investigation Peer Reviewed by Mechanical Engineering and Mechanical Analyses Branches*
  - *Investigation Results Documented in ACD-RPT-000345*

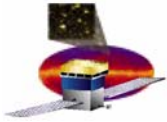

ACD PER



8 June 2005

# ◆ ***DETECTOR TESTS PERFORMED***

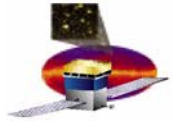

ACD PER

# Component Tests Performed Vibration and Acoustics Tests



8 June 2005

- ◆ ***Tile Detector Assembly Engineering Model Vibration Test***
  - ***Test plan document***
    - *Vibe Plan # ACD-PLAN-000032*
  - ***Detector Vibration Tests performed Oct 2002.***
  - ***Pre and post performance test showed no change in performance.***

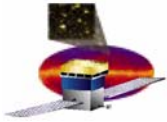

ACD PER

## Changes Since Mechanical Qualification



8 June 2005

- ◆ *TSA Moved up 0.040" relative to BFA*
- ◆ *MMS Standoffs Re-fabricated with opaque material*
- ◆ *Reduced the fly away accelerometers from 21 to 9*
- ◆ **ADDED**
  - ***TSA Core Grounding***
    - *Cut Holes in Composite Panels. Holes Filled with an insert and conductive adhesive*
  - ***MMS Grounding***
    - *Added Mass to Electronics' Cover*
  - ***Detector Fiber Bundle Strain Relief***
    - *Concern about forces on constrained detector cables*
      - *Analyses being performed*
      - *Loosely tied 33 of 194 fiber bundles to TSA*

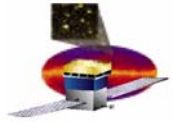

# ◆ ***ACD ASSEMBLY LEVEL MECHANICAL VERIFICATION TESTS***

## ◆ ***Test Program***

- ***Sine Vibration Test***
- ***Acoustic Test***
- ***Mass Properties Test***
- ***Mechanical Survey***

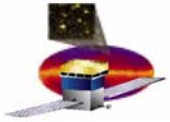

ACD PER



8 June 2005

# ◆ ***PRE-TEST ANALYSES***

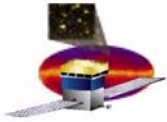

**ACD PER**

# Test Reference Documents



**8 June 2005**

- ◆ **LAT Environmental Specification, LAT-SS-00778**
- ◆ **GLAST-LAT Vibration Subsystem Levels, SAI-TM-2487**
- ◆ **ACD Design Loads and Environmental Test Guidelines, *ACD-RQMT-000183***
- ◆ **General Environmental Verification Specification (GEVS) for STS and ELV Payloads, Subsystems, and Components, *GEVS-SE Rev. A, June 1996***
- ◆ **ACD Structural qualification Vibration Test Plan, *ACD-PLAN-000187***
- ◆ **ACD – EU Double Row Channel Static Pull Test Plan, *ACD-PLAN-000202***
- ◆ **ACD Acoustic Vibration Test Plan For The Qualification Structure, *ACD-PLAN-000196***
- ◆ **LAT ACD Subsystem - ACD Verification Table/Plan, *ACD-PLAN-000050***

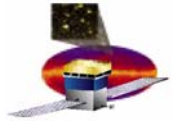

ACD PER

## Mechanical Analysis Margins of Safety



8 June 2005

### ◆ *Margins of Safety*

- *All components have been analyzed and shown to have positive margins of safety*
- *A summary table is provided on the following two slides*

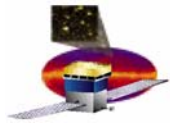

ACD PER

# Margins of Safety



8 June 2005

Component	MS <sub>yield</sub>	MS <sub>ult</sub>	MS <sub>no-test</sub>	Failure Mode	Load Applied	Analyst	Comments
<b>BEA</b>							
Electronic Chassis	0.37	0.37		PMT rail bending	30 g Body	Dahya	Individual X,Y,Z load applied. Worst Case is out of plane.
Chassis I/F Fast.	2.20	2.60		Tension	30 g Body	Dahya	30 G load applied to Chassis. Worst case out of plane
PMT I/F Fast.	2.84	3.37		Tension	30 g Body	Dahya	MS calculated from 30 G load applied to PMT.
<b>BFA</b>							
Channel section		0.23		Buckling	7.5 lat, 8.5 th	Dahya	Based on new test loads derived.
Chan-to-Chan I/F fasteners	6.10	7.40		Tension	7 g body	Dahya	Based on old acoustic loads from 7/10/03. Load applied on full ACD Model
Chan-to-Chan I/F pins		7.10		Shear	7 g body	Dahya	Based on old acoustic loads from 7/10/03. Load applied on full ACD Model
Midspan I/F bolts			1.17	Tensile	DLL	S. Wall	
Shear Pin			0.17	Shear	DLL	S. Wall	
Snubber			0.47	Tensile/Shear	DLL	S. Wall	
Snubber tear out			0.08	Tear out	DLL	S. Wall	
Corner bolts			0.21	Tensile/Shear	DLL	S. Wall	
Flexure bolts corner		0.67		Tensile/Shear	DLL	S. Wall	
Flexure bolts midspan		0.72		Tensile/Shear	DLL	S. Wall	
<b>PMT</b>							
Verified by test							Thermally-induced stresses looked at for design purposes
<b>MGSE</b>							
Mid posts	0.23	0.13			1807 lbf	Kunt, Dahya	Static test loads used, 7.5 g lateral and 8.5 g thrust
Corner posts	2.00	1.16			14.26 ksi	Kunt, Dahya	
Mid-post fasteners	2.44	2.90			13.8 ksi	Kunt, Dahya	
Mid-post shear pins	0.65	0.52			10.6 ksi	Kunt, Dahya	
Corner-post fasteners	8.63	7.51			3.3 ksi	Kunt, Dahya	
Corner-post shear pins	4.33	2.84			2.2 ksi	Kunt, Dahya	

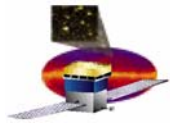

ACD PER

# Margins of Safety



8 June 2005

Component	MS <sub>yield</sub>	MS <sub>ult</sub>	MS <sub>no-test</sub>	Failure Mode	Load Applied	Analyst	Comments
<b>TDA</b>							
Tile, Side-4			1.59	Bending	660 psi	C. Kunt	Acoustic load
Tile, Side-3			0.27	Bearing	2025 psi	C. Kunt	Acoustic load
Tile, Side-4			0.36	Compression	3280 psi	C. Kunt	Acoustic + preload
Bottom tile			4.20	Bending	330 psi	C. Kunt	Acoustic load
Blade flexures, Top-1		0.45		Delamination	3300 psi	C. Kunt	Thermally induced 0.035" displacement; 1.5 FS
Blade flexures, Top-3		2.10		Delamination	1540 psi	C. Kunt	Acoustic load on strong axis; FS = 1.50
Blade flexures, Top-3		0.95		Core Crushing	123 psi	C. Kunt	Acoustic load; FS = 1.50
Blade flexures, Bottom tile		13.55		Bond peel	495 psi	C. Kunt	Thermally induced 0.267" displacement
Blade flexures, Bottom tile		0.27		Bending	105.2 ksi	C. Kunt	Thermally induced 0.267" displacement
Blade flexures, Bottom tile		0.98		Bond peel	2.42 ksi	C. Kunt	Acoustic load on strong axis; FS = 1.50
Post flexure, Bottom tile		0.12		Bending	109.4 ksi	C. Kunt	Thermally induced 0.325" displacement
Post flexure, Bottom tile		3.18		Buckling	17.9 lb	C. Kunt	Acoustic load on strong axis; FS = 1.50
Upper Tile Screw Side-4		0.15		g	139 ksi	C. Kunt	Acoustic load
<b>TSA</b>							
Midspan lift point		28.00		Compression	928 psi	S. Wall	Worst case is the face sheet; fitting and core are even better
Midspan fitting		3.21		Bearing	DLL	S. Wall	
Midspan face sheet		0.17		Compression	DLL	S. Wall	
Midspan core		0.08		Compression	DLL	S. Wall	
Corner fitting		4.62		Bearing	DLL	S. Wall	
Corner face sheet		0.30		Compression	DLL	S. Wall	
Corner core		0.11		Compression	DLL	S. Wall	
Midspan flexures			0.31	Buckling	8.5 g	S. Wall	
Corner Flexures			0.58	Buckling	8.5 g	S. Wall	
Honeycomb panel venting		0.76		Blow out	9974 psi	S. Wall	Core ribbon analysis
MMS Standoff Base		0.23		Bending	12 g lateral	S. Chaykovsky	Standoff Base
MMS Standoff Post		0.02		Bending	12 g axial	S. Chaykovsky	Standoff Post
MMS Spring Retainer		High		Compression	12 g axial	S. Chaykovsky	Spring Retainer
MMS Angled Standoff Base		0.23		Bending	12 g lateral	S. Chaykovsky	Standoff Base, angled

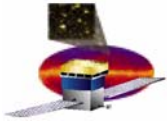

# Test Levels



◆ **Swept sine and acoustic protoflight levels**

- *Sine testing will be limited to structural qualification test responses if required*
  - *X and Y-axes = 3.5g on the TSA*
  - *Z-axis = 4.0g on the TSA*

X & Y Axes Sine Sweep Protoflight Level		
Frequency (Hz)	Level (g, 0-pk)	Sweep Rate (oct/min)
5-15	2.5	4.0
15-25	0.9	4.0
25-35	0.9	1.5
35-40	0.9	4.0
40-50	1.9	4.0

Z Axis Sine Sweep Protoflight Level		
Frequency (Hz)	Level (g, 0-pk)	Sweep Rate (oct/min)
5-15	0.4	4.0
15-25	1.2	4.0
25-35	2.7	1.5
35-50	0.7	4.0

Acoustic Protoflight Level	
1/3 Octave Center Frequency (Hz)	Protoflight Test Levels (dB)
31.5	127.4
40	130.3
50	134.2
63	135.1
80	137.4
100	134.9
125	133.6
160	131.6
200	132.4
250	129.6
315	126.4
400	122.9
500	122.1
630	119.6
800	120.5
1000	120.2
1250	121.4
1600	122.0
2000	120.0
2500	120.3
3150	118.6
4000	116.0
5000	111.9
6300	107.9
8000	104.8
10000	102.8
<b>Overall Sound Pressure Level (OASPL)</b>	<b>143.8</b>
<b>Duration</b>	<b>60 sec.</b>

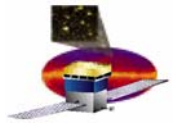

ACD PER

# Test Configuration Swept Sine Vibration



8 June 2005

- ◆ **BFA and TSA shown on the vibration fixture**
  - 2" plate
  - Eight mounting posts representing LAT I/F
- ◆ **Not Shown**
  - Additional 3" plate for thrust axis vibration
  - Electronic Chassis

- Removable accelerometer locations (accels located on inside of TSA)
- Fly-away accelerometers

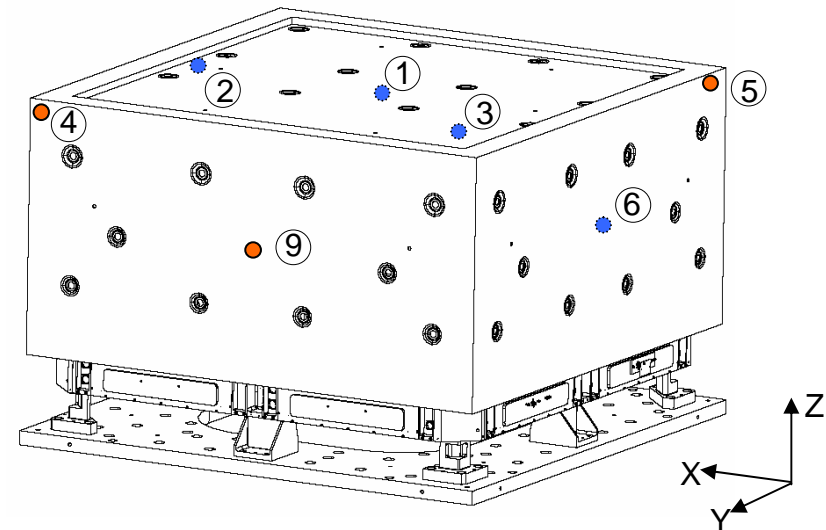
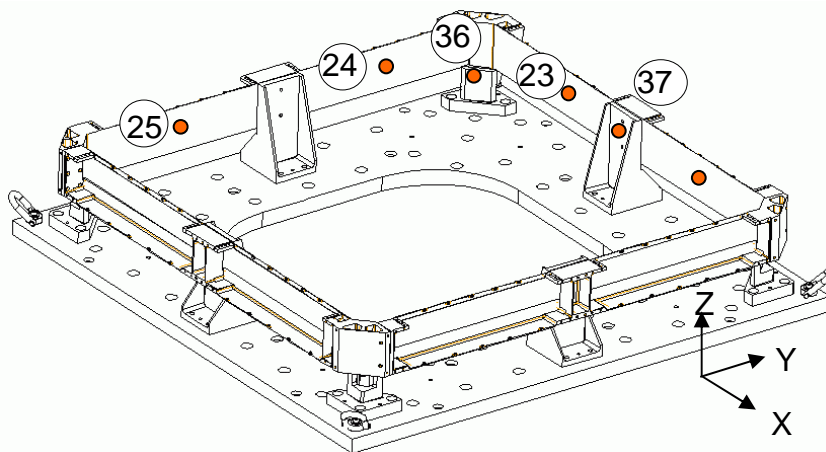
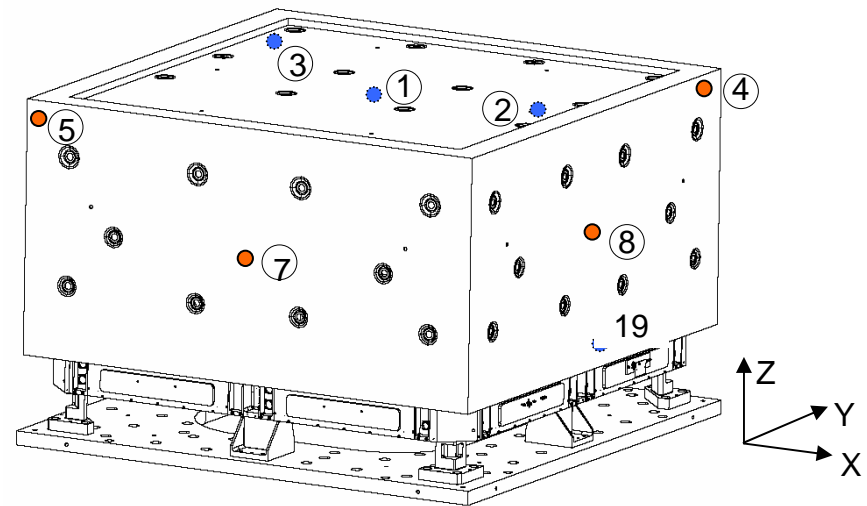

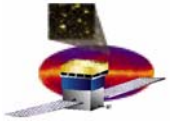

ACD PER

## ACOUSTIC TESTING



8 June 2005

◆ **NOTE:**

- *Acoustic verification is to be performed on the fully integrated ACD instrument*

◆ **Test configuration**

- *Structure will sit on the ACD dolly*
- *TSA cavity closed out at the vibe fixture*
- *Internal microphone installed*
- *Accelerometers same as in vibration tests*
- *MMS installed*
- *Protoflight acoustic levels used*

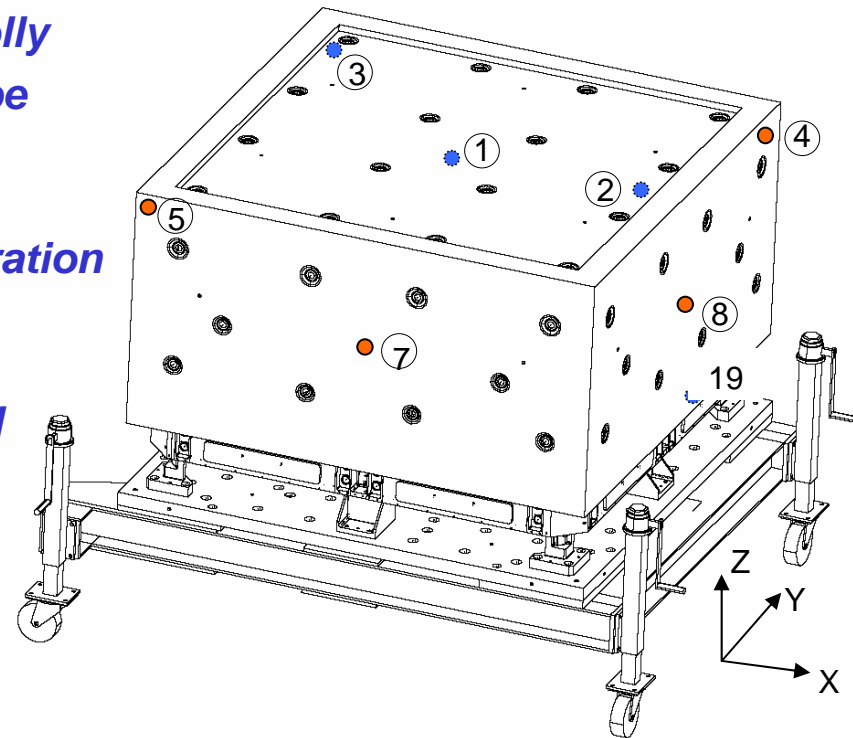

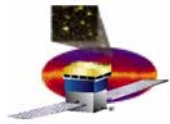

ACD PER

# MASS PROPERTIES



8 June 2005

## ◆ **ACD Mass and CG**

- **Mass Requirement < 295Kg**
- **Current Estimate = 277kg :**
  - *Includes Shell Assembly, Instrument Harness, 8 Electronic Chassis, 89 Tile Detectors and Optical Connectors*
    - 81.4% weighed
    - 14.2% calculated – MMS Not yet Weighed
    - 4.4% estimated
      - **MMS Grounding Hardware Mass , 8 Assemblies ~ 50g each**
      - **Clear Fiber Cable Strain Relief Mass, 12 parts at ~ 24g each**

## ◆ **ACD CG**

- **Requirement is**
  - *X and Y = 0*
  - *Z < 340mm where Z=0 is the LAT Frame of Reference*
- **Estimated CG is Z= 318mm**
  - *Based on FEM Math Models*

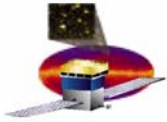

ACD PER

# MASS TESTING



8 June 2005

- ◆ ***MASS and CG Test Configuration***
  - *Fully Assembled ACD Instrument*
  - *ACD Secured to Vibration Test Setup and 3” plate*
    - *Mass and CG of 3” plate and Vibration Setup Measured*
- ◆ ***Procedure Needs to be Written***

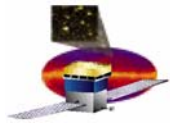

ACD PER



8 June 2005

# MECHANICAL SURVEY

- *Mechanical Survey Already Performed on ACD with 65 Tiles Installed*
- *Inside Volume*
  - **Baseframe Area**
    - *MIN requirement 1574mm*
    - *MIN dimension measured 1573.9mm*
  - **Tracker Stayclear Area**
    - *MIN Requirement 1515.5mm*
    - *MIN Dimension measured 1509.7mm – On Thermister Wire- Rework Planned*
    - *MIN Dimension measured on Structure 1519.3mm*
- *Outside Volume*
  - **Width**
    - *MAX requirement 1820mm x 1820mm*
    - *MMS Standoffs measured at 1790.4mm*
    - *16 More Standoffs gave been installed and need to be measured*
      - *anticipate measurement to be 1790 +/- 3mm*
  - **Height**
    - *MAX requirement 1050mm*
      - *MMS Standoff measured at 1020.4mm*
- *REQUIRE MEASUREMENT OF MMS/MLI AFTER IT IS INSTALLED*

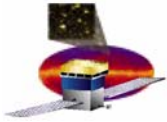

ACD PER

# CONCLUSION



8 June 2005

- ◆ **ACD Component Qualifications Complete**
- ◆ **ACD System Pre-Test Analyses are Complete**
- ◆ **MGSE**
  - **Complete**
    - Lift Sling
    - Vibration Plates (3" and 2" Plates)
  - **Being Assembled**
    - MMS Lift Sling (Analyses Complete, will be tested)
    - T-Vac 2" Plate Assembly
- ◆ **Plan/Procedures Status**
  - **In Review**
    - Updated ACD Handling Procedure
    - Acoustic and Vibration Plans
    - MMS Handling Procedure
  - **Needs to be Written**
    - Mass Properties Test Plan

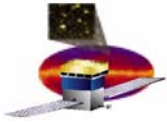

**ACD PER**



**8 June 2005**

# **System Test Planning Thermal Test Overview**

***ACD Thermal Subsystem***

***Carlton V. Peters***

***ACD Thermal Engineer***

***GSFC, Code 545***

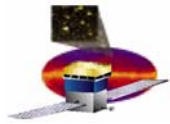

# ACD Design Configuration



ACD PER

8 June 2005

- ◆ *Anticoincidence Detector covers all five external sides of the LAT*
- ◆ *External MLI Blanket has 3 mil Germanium Black Kapton outer layer and is composed of 14 blanket layers*
- ◆ *Blanket will be attached using a combination of standard blanket attachments such as double sided tape and blanket buttons.*
- ◆ *Micrometeoroid shield includes approximately 3 cm of Solomide foam, Kevlar and Nextel layers*
- ◆ *Thin composite, low conductivity shell provides ACD structural support*
- ◆ *High emittance tracker exterior surfaces provide radiative path between tracker and ACD Shell interior*
- ◆ *Electronics Boards mounted to BEA Rail*
- ◆ *No dedicated radiator*
- ◆ *BEA mounted to grid at the 4 corners via corner fittings and at the center of each side by mid-span connectors*

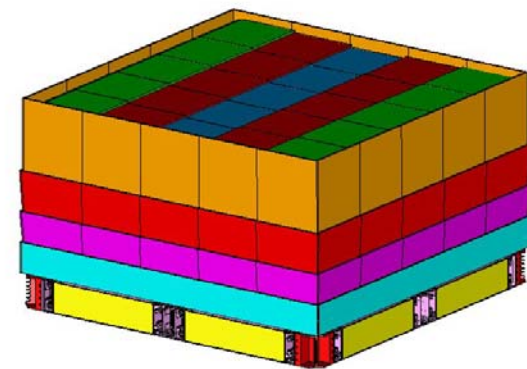

## ACD Cross-Section

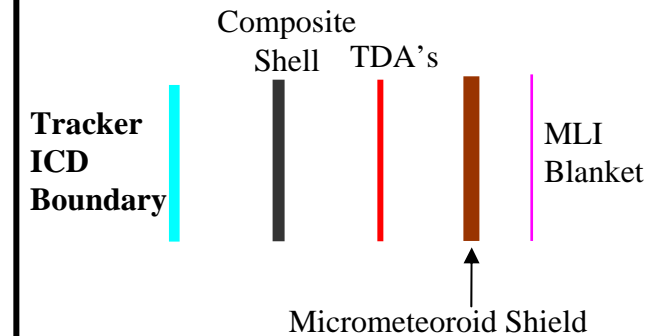

## Electronics Thermal Schematic

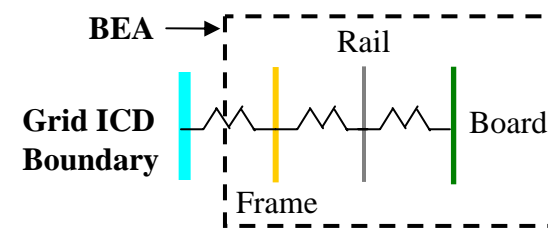

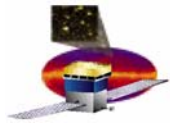

## ***Tile Detector Assembly***

- ◆ ***Passive thermal design approach***
- ◆ ***The following ACD characteristics argue for a thermal design approach based on local thermal environment considerations for any of the five sides:***
  - *LAT Point anywhere anytime viewing requirements*
  - *TDA's located on all five ACD exterior sides*
  - *Poor lateral thermal conduction characteristics through the ACD TDA structural support (low conductivity composite shell)*
  - *No dedicated radiator*

## ***Electronics Board Interface***

- ◆ ***Passive thermal design approach without survival heaters***
- ◆ ***Electronics board interface temperatures are driven by the grid cold sink boundary temperature since heat transfer from the board interface to the grid is through a radiative heat transfer path and a series conduction heat transfer path.***

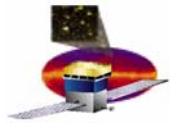

ACD PER

# System Test Planning Thermal Test Overview



8 June 2005

◆ *Thermal test tree*

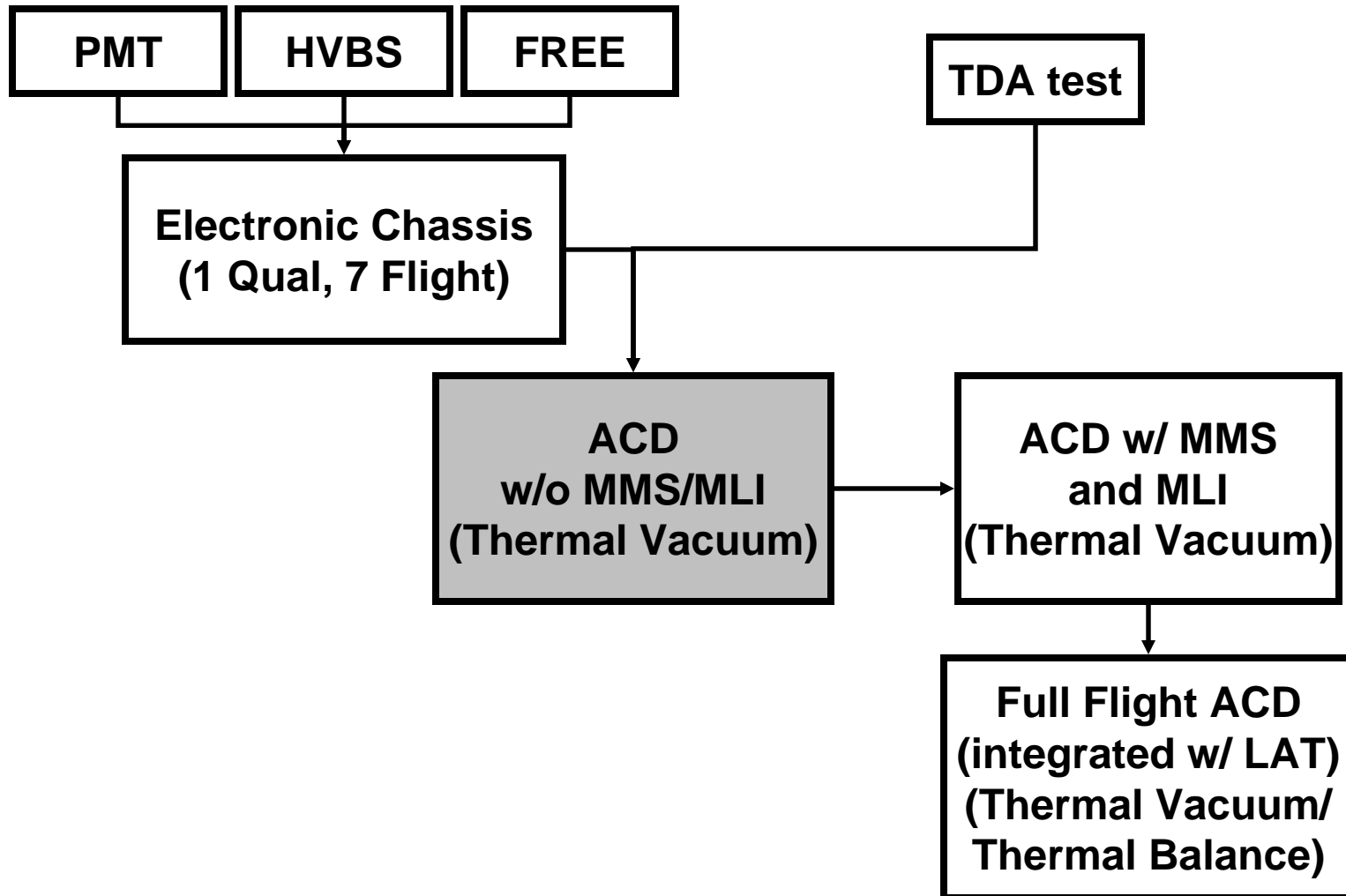

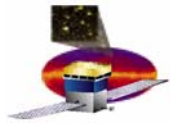

ACD PER

# System Test Planning Thermal Test Overview



8 June 2005

## ◆ *Thermal Vacuum test levels*

### – *Qualification*

- *TDA: -40 °C to +45 °C*
- *PMT: -30 °C to +40 °C*
- *Free Board: -30 °C to +40 °C*
- *HVBS: -30 °C to +40 °C*
- *Electronic Chassis: -30 °C to +40 °C*
- *ACD: -25 °C to +40 °C (Per LAT-SS-00778-02 – LAT Environmental Specification)*

### – *Acceptance*

- *TDA: -30 °C to +35 °C*
- *PMT: -20 °C to +35 °C*
- *Free Board: -20 °C to +35 °C*
- *HVBS: -20 °C to +35 °C*
- *Electronic Chassis: -20 °C to +35 °C*
- *ACD: -20 °C to +35 °C (Per LAT-SS-00778-02 – LAT Environmental Specification)*

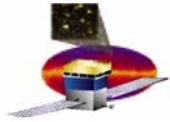

ACD PER

# System Test Planning Thermal Test Overview



8 June 2005

- ◆ ***PMT Engineering models (Thermal Vacuum)***
  - *ACD PMT Qualification - Thermal Vacuum and Corona Test (ACD-PROC-000260), 2.5 cycles from -30 °C to +40 °C*
  - *This test was conducted in the chamber located in Building 2, room S025 in November 2004*
- ◆ ***PMT Flight units (Thermal Vacuum)***
  - *ACD PMT Qualification - Thermal Vacuum and Corona Test (ACD-PROC-000260) , 2.5 cycles from -30 °C to +40 °C*
  - *This test was conducted in the chamber located in Building 2, room S025 in November 2004*
  - *PMTs were also thermal cycled in building 30 from -30 °C to +40 °C*
- ◆ ***Test Report***
  - *TDA-PMT-Resistor Network End-to-End Thermal-Vacuum Test Report (ACD-RPT-000082)*
- ◆ ***Test Issues - none***

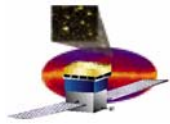

ACD PER

# System Test Planning Thermal Test Overview



8 June 2005

- ◆ ***FREE and HVBS Engineering models (Thermal Cycling)***
  - *GLAST LAT ACD FREE Thermal Performance Test (ACD-PROC-000150)*
  - *LAT ACD High Voltage Bias Supply Thermal Vacuum Test Procedure (ACD-PROC-000140)*
  - *FREE Tests performed in March 2004, in Tenney chamber in ACD LAB*
  - *HVBS performed in Vacuum chamber in facility Building 2 room S025*
  - *Tests performed from -30 °C to +60 °C*
- ◆ ***FREE and HVBS Flight units (Thermal Cycling)***
  - *GLAST LAT ACD FREE Thermal Performance Test (ACD-PROC-000150)*
  - *HVBS Test Procedure (ACD-PROC-000064)*
  - *HVBS Tests performed in August 2004, in Tenney chamber in ACD LAB*
  - *FREE Tests performed in July 2004, in chamber in Building 2 room S025*
  - *Tests performed from -20 °C to +50 °C*
- ◆ ***Test issues - None***

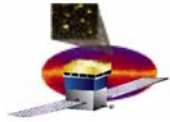

ACD PER

# System Test Planning Thermal Test Overview



8 June 2005

- ◆ **Electronic Chassis engineering model (Thermal Vacuum)**
  - *ACD Electronic Chassis Thermal Vacuum Test Plan (ACD-PLAN-000173)*
  - *This test was conducted in the chamber located in Building 2, room S025 in February 2005*
  - *12 cycles performed from -30 °C to +40 °C*
- ◆ **Electronic Chassis flight units (Thermal Vacuum)**
  - *ACD Flight Electronic Chassis Thermal Vacuum Test Plan (ACD-PLAN-000308)*
  - *These test were conducted in the chamber located in Building 2, room S025 over the time period of February 2005 – May 2005*
  - *4 cycles performed from -20 °C to +35 °C*
- ◆ **Test issues - None**

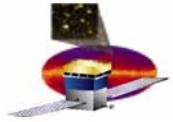

ACD PER

# System Test Planning Thermal Test Overview



8 June 2005

- ◆ ***TDA Engineering model test (Thermal Vacuum)***
  - *TDA-PMT-Resistor Network End-to-End Thermal Vacuum Procedure (ACD-PROC-000068)*
  - *This test was performed in Building 4 room 191 in the 36 inch chamber in November of 2002*
  - *5.5 cycles performed from -60 °C to +45 °C*
- ◆ ***Test Report***
  - *TDA-PMT-Resistor Network End-to-End Thermal-Vacuum Test Report (ACD-RPT-000082)*
- ◆ ***Test Issues - None***

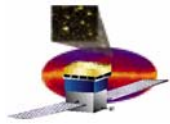

ACD PER

# System Test Planning Thermal Test Overview



8 June 2005

- ◆ **ACD Flight unit (Thermal Vacuum)**
  - **ACD Flight TV Test Plan (ACD-Plan-000347)**
  - **ACD Thermal Vacuum test will be performed in Facility 290 in building 10 in June of 2005**
    - Backup is facility 225 located in building 7
  - **The ACD will be in it's flight configuration without the Micrometeoroid shield and Multi-Layered insulation for part of the test and will be in it's flight configuration with the MMS but without the MLI for part of the test**
  - **Test Flow**
    - For the first four cycles of the ACD TV test, the ACD without the MMS and MLI, will be cycled to qualification temperatures
    - First cold and first hot cycles will be to survival limits
    - After 4<sup>th</sup> TV cycle there will be a chamber break to install MMS and MLI on ACD
    - Fifth and final cycle will be to temperature extremes to fully mechanically stress ACD MMS and MLI mechanical support attachments

# ACD PER

ACD TV TEST PROFILE  
06/03/05

# ACD PER



8 June 2005

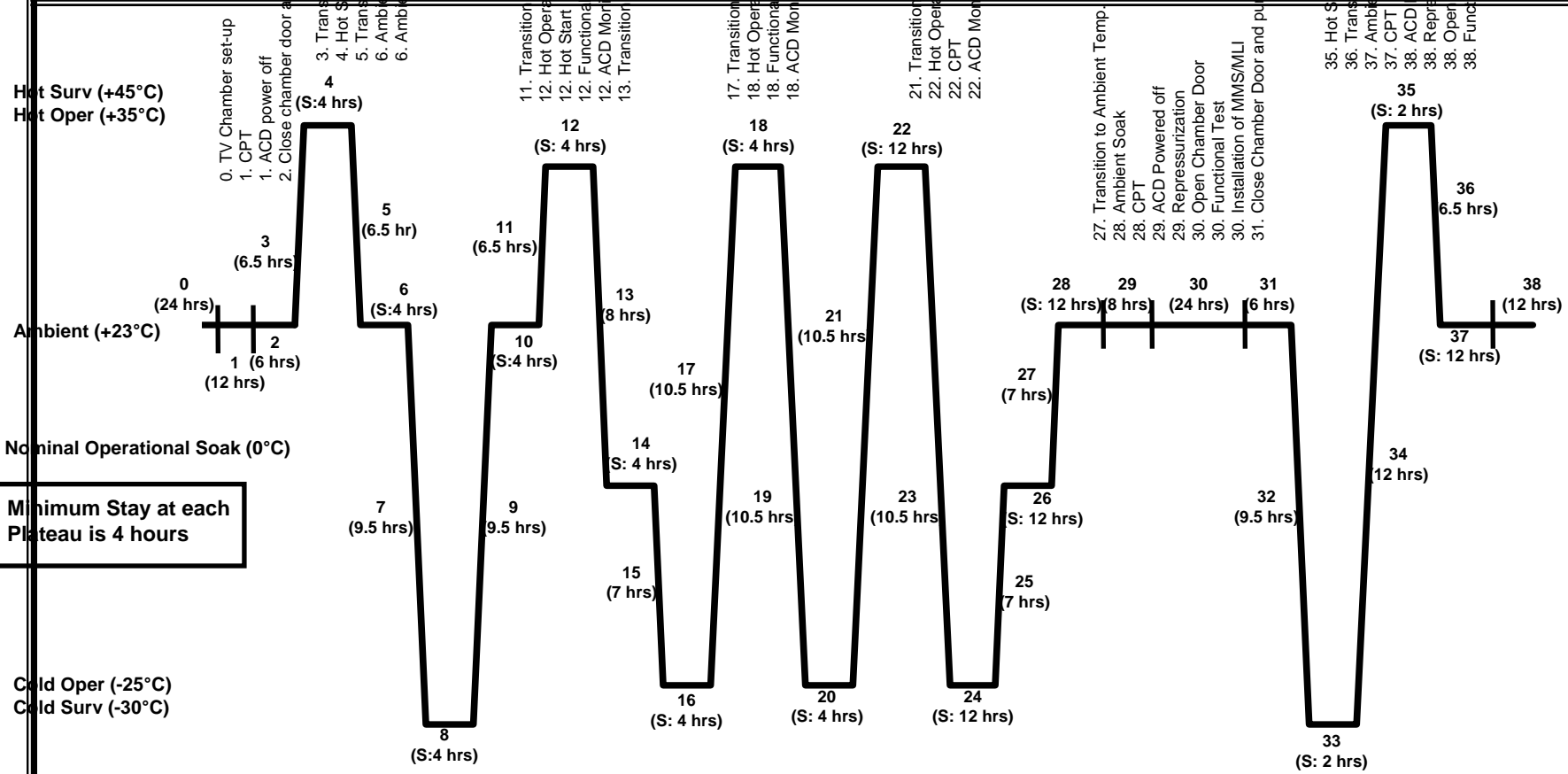

Minimum Stay at each Plateau is 4 hours

- 0. TV Chamber set-up
- 1. CPT
- 1. ACD power off
- 2. Close chamber door and pumpdown
- 3. Transition to Hot Survival
- 4. Hot Survival Soak
- 5. Transition to ambient temp.
- 6. Ambient Temp. Soak
- 6. Ambient Functional test
- 7. Transition to Cold Survival
- 8. Cold Survival Soak
- 8. Transition ambient temp.
- 9. Ambient Temp. Soak
- 9. Ambient Functional test
- 10. Transition to Hot Op. Temp.
- 11. Hot Operational Soak
- 12. Hot Start
- 12. Functional test
- 12. ACD Monitor
- 13. Transition to Nominal Op. Temp.
- 14. Nominal Op. Temp. Soak
- 14. Functional test
- 14. ACD Monitor
- 15. Transition to Cold Op. Soak
- 16. Cold Operational Soak
- 16. Functional test
- 16. ACD Monitor
- 17. Transition to Hot Op. Temp.
- 18. Hot Operational Soak
- 18. Functional test
- 18. ACD Monitor
- 21. Transition to Hot Op. Temp.
- 22. Hot Operational Soak
- 22. CPT
- 22. ACD Monitor
- 23. Transition to Cold Op. Temp.
- 24. Cold Operational Soak
- 24. CPT
- 24. ACD Monitor
- 25. Transition to Nominal Soak
- 26. Nominal Soak
- 26. CPT
- 26. ACD Monitor
- 27. Transition to Ambient Temp.
- 28. Ambient Soak
- 28. CPT
- 29. ACD Powered off
- 29. Repressurization
- 30. Open Chamber Door
- 30. Functional Test
- 30. Installation of MMS/MLI
- 31. Close Chamber Door and pump down
- 35. Hot Survival Soak
- 36. Transition to Ambient
- 37. Ambient Soak
- 37. CPT
- 38. ACD Powered off
- 38. Repressurization
- 38. Open Chamber Door
- 38. Functional Test

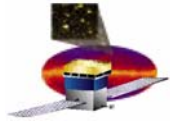

ACD PER

# Summary



8 June 2005

- ◆ ***ACD Flight Hardware at the component level has been thermally tested to a sufficient level***
- ◆ ***Electronic Chassis sub assembly has been thoroughly tested to the recommended testing levels***
- ◆ ***ACD subsystem will be tested to the specified levels between testing being conducted at the ACD level and at the higher LAT level***

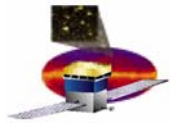

ACD PER



8 June 2005

# VERIFICATION SUMMARY

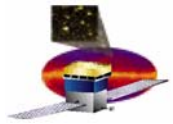

# ACD Science Requirements Verification Summary- 1



- Some important requirements flow through a science simulation, because direct measurement is impractical (no calibrated source of cosmic rays).

## ACD Simulation Measured Input Parameters

### Active elements

- Tile performance
- PMT performance
- Ribbon performance
- Flight configuration channel light throughput

### Passive elements

- Clear fiber performance
- Wave shifting fiber performance
- Fiber connectors performance

### Dead area

- Gaps between tiles and at corners

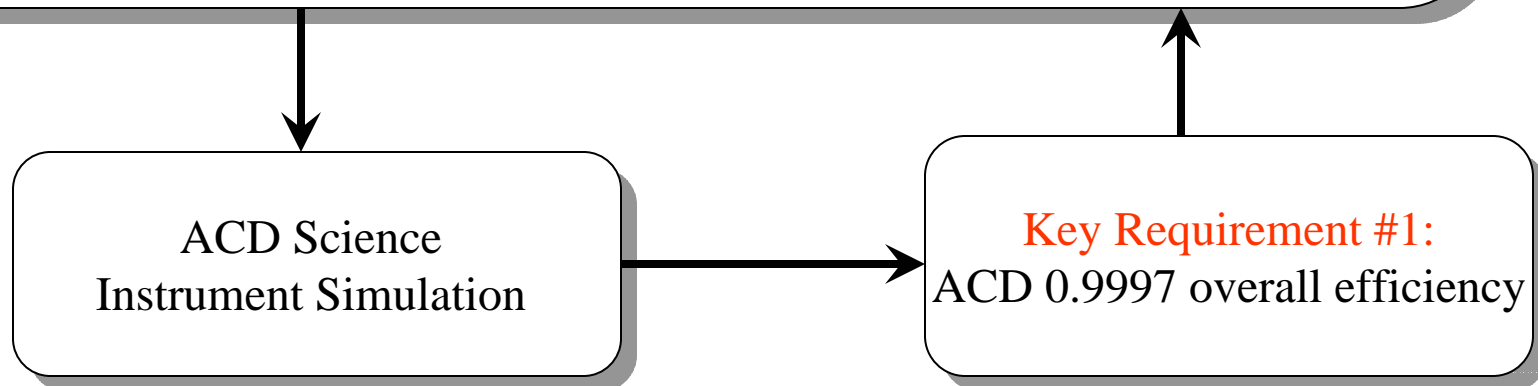

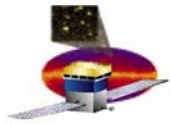

ACD PER

# ACD Science Requirements Verification Summary - 1



8 June 2005

- Performance of all detector elements has been measured in a laboratory setup, using ground-level muons as a source.
- These measurements were compared to a simulation of the same geometry.
- The same simulation was used for the ACD geometry, based on measurements during assembly.
- The calculated efficiency meets the requirement at the planned operating point.
- Margin for loss of detector signals is obtained by operating at a lower threshold.

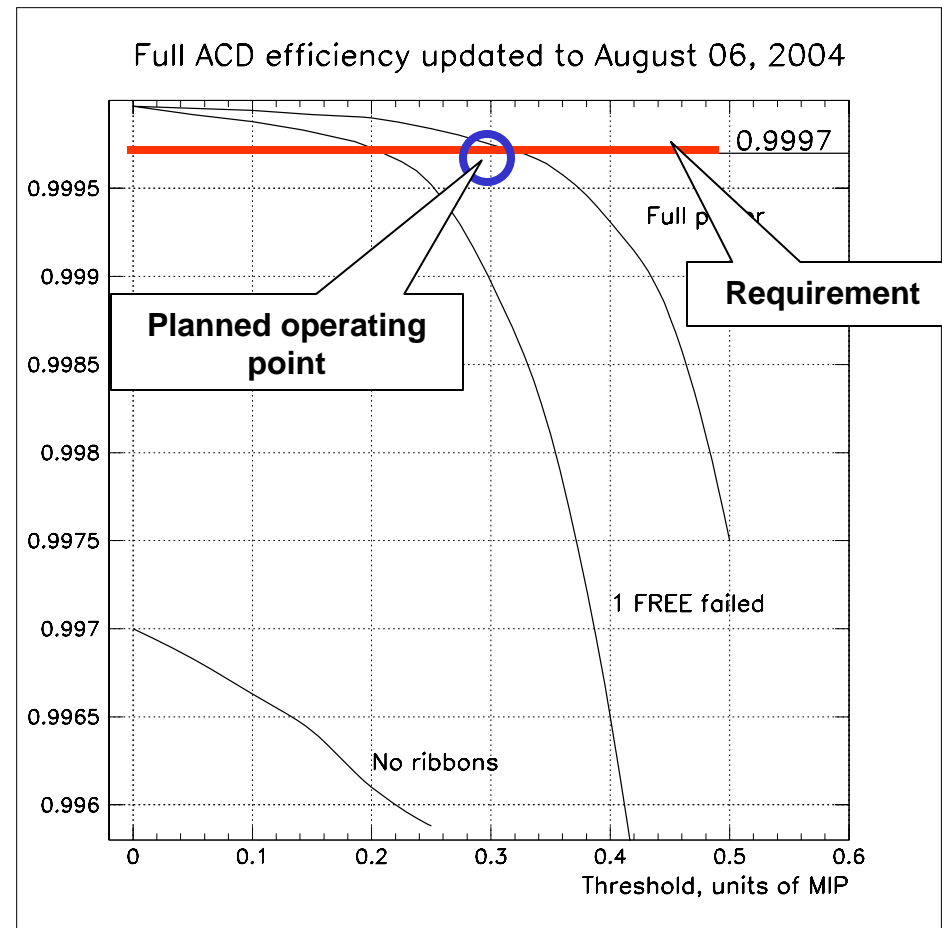

**GLAST LAT ACD FULL PERFORMANCE  
ANALYSIS REPORT, ACD-RPT-000271**

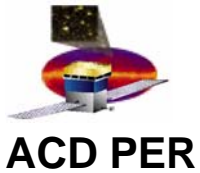

# ACD Science Requirements Verification Summary- 2



8 June 2005

- Some important requirements flow through a science simulation, because direct measurement is impractical (no calibrated source of cosmic rays).

## ACD Simulation Measured Input Parameters

### Active elements

- Tile performance
- PMT performance
- Flight configuration channel light throughput

### Passive elements

- Calorimeter (source of backplash that produces self-veto)

### Geometry

- Tile locations with respect to calorimeter

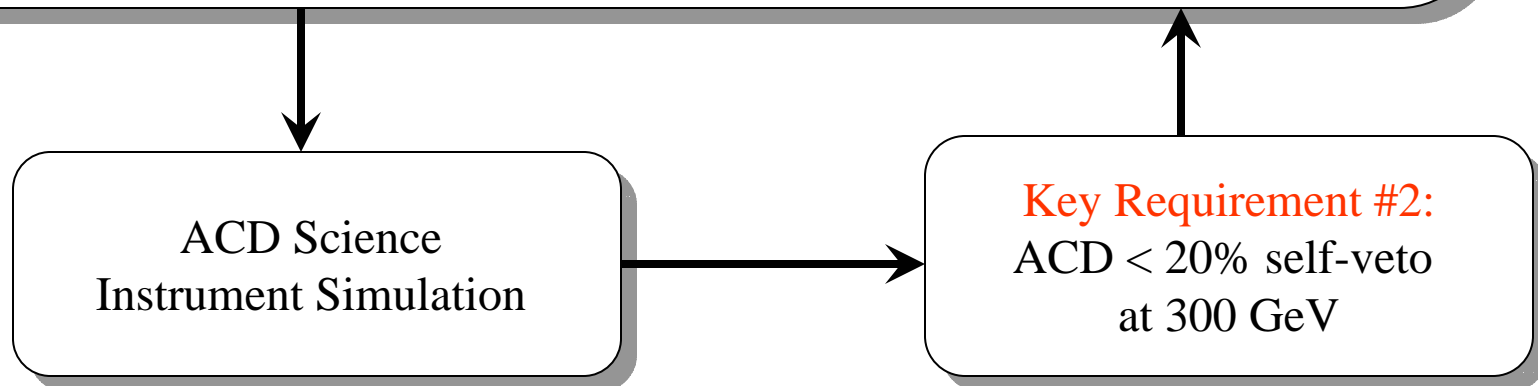

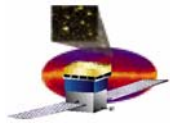

ACD PER

# ACD Science Requirements Verification Summary- 2



8 June 2005

- A set of tiles and calorimeter emulators was taken to CERN in 2002.
- Measurements were made of the energy, angle, and material dependence of the backslash.
- These measurements were compared to a simulation of the same geometry.
- The same simulation was used for the ACD geometry
- The calculated backslash at 300 GeV is 7%, well below the 20% requirement.
- Even at a threshold of 0.12, ACD would meet its requirement.

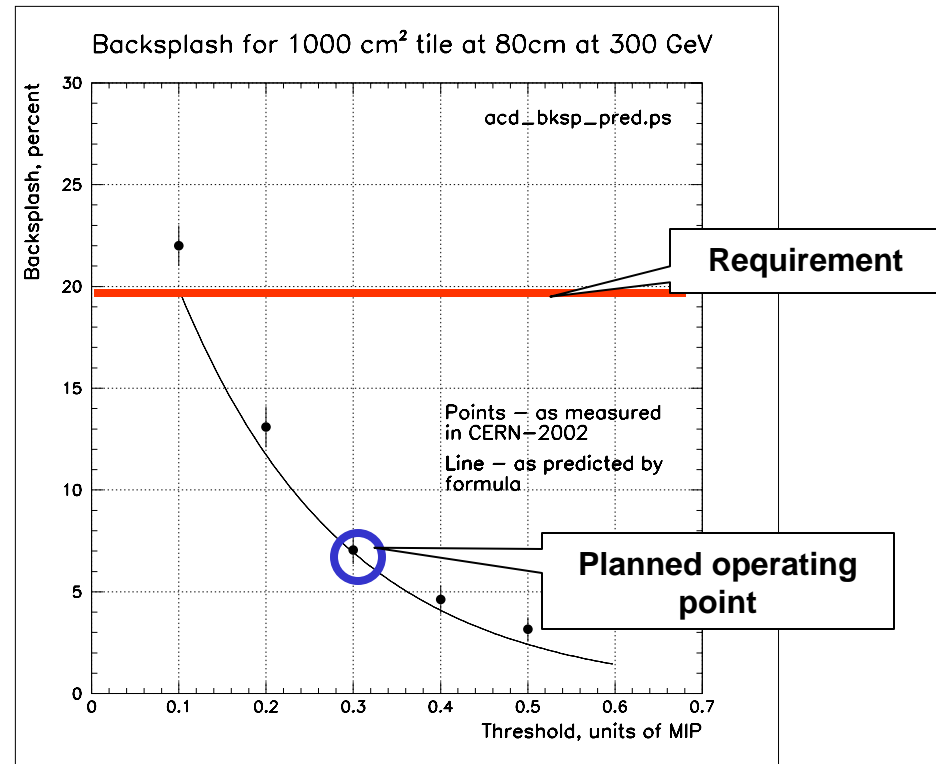

Moiseev et al. 2004, Astroparticle  
Physics 22, 275

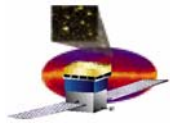

ACD PER

## Completed Verification Results Summary- Important System performance results



8 June 2005

### Important system performance analysis

- ◆ **Efficiency – requirement 0.9997**
  - Verified - Simulation using as-measured inputs shown above. While the inputs have been verified the overall efficiency cannot be fully measured on the ground. The simulation has been reviewed and is in CM. The upcoming calibration run will give us some further confirmation of the measured detector performance input to the simulation.
- ◆ **False veto rate – requirement <20% backslash, <1% noise**
  - Verified – backslash <10% was measured in runs at CERN, using ACD-type detectors and LAT-like calorimeter, plus simulation of detailed ACD geometry. Noise was measured during CPT.
- ◆ **Fast veto signal – requirement – discriminator pulses, variable width**
  - Verified – CPT verified logic pulses, bench tests verified widths
- ◆ **PHA signal – requirement – Minimum Ionizing Pulses (MIP), CNO pulses**
  - Verified – CPT verified PHA for MIP; Test Charge Injection verified CNO

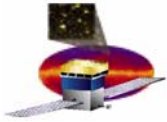

ACD PER

## Completed Verification Results Summary - ETU tests



8 June 2005

- ◆ ***ACD is primarily a proto-flight, there was no full size engineering model***
- ◆ ***Subsystem ETU where done on all of our functional subsystems. Results were successful and met requirements. Some required design modifications and retest. (For example -PMT mount, addition of FREE cross talk shield).***
- ◆ ***Two of ACD's major science performance related subsystems, the Tile Detector Assembly and Electronics Chassis both had full engineering model tests that were successful (other than the PMT mount)***
- ◆ ***List of Engineering test unit tests***
  - ***Tile detector assembly (4 types, signal performance, mechanical and thermal tests)***
  - ***Electronics chassis (double row, electrical performance, mechanical, thermal and EMI tests)***
  - ***Detector flexures (mechanical tests)***

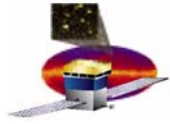

ACD PER

# Completed Verification Results Summary - Life testing



8 June 2005

- ◆ *Life testing of all items is complete and the design appropriately reflects results. **ACD has no items that qualify as “limited life” when compared to the 10 year mission lifetime.***
- ◆ *List of life tested parts*
  - *GARC*
  - *GAFE*
  - *PMTs*
  - *HVBS capacitor*

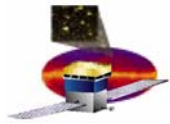

ACD PER

## Completed Verification Results Summary- Verification Status



8 June 2005

- ◆ *Requirement verification activities continue*
- ◆ *135 Level 4 requirements and 95 ICD items*
- ◆ *Any LAT Environmental Specification and LAT Verification Plan requirements are captured and referred to by level 4 and ICD requirements*
- ◆ *We come to PER without the system level functional and performance tests complete. These tests need to be successfully completed before ACD environmental testing*
- ◆ *Instead of delaying PER at the last minute we intend to forward results summary to the PER team at completion of those tests.*
- ◆ *Comments and actions from that report will be processed and answered before proceeding.*
- ◆ *The ACD system lends itself to a great deal of subsystem verification.*
- ◆ *Requirements are not always written perfectly. Since CDR the full set of ACD requirements has recently been repeatedly reviewed internally (science team, leads, systems, etc..) for testing weaknesses and any other issues.*
- ◆ *DOORS system down quite some time. Using Excel replacements for tracking updates at this point.*

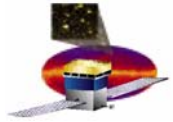

ACD PER

# Completed Verification Results Summary- Verification table status



8 June 2005

## ***MECHANICAL SUMMARY***

- ◆ ***The ACD mechanical system lends itself to a great deal of subsystem verification.***
- ◆ ***Most of the mechanical requirements are verified at the subsystem level via subsystem engineering and flight unit vibration, thermal and strength tests. (see environmental test flow for subsystem flight and engineering units)***
- ◆ ***Mechanical requirements yet to be verified ;***
  - ***Final mass properties, Mass, CG in Z direction, Major unmeasured component is assembled MMS/MLI.***
  - ***Fully assembled ACD system level Sine Vibration and Acoustic tests***
  - ***Final stay clear survey (many hard point measurements are complete, MLI/MMS installation required to complete)***
  - ***MGSE - MMS lift sling verification test***
  - ***Thermal Performance of MLI blanket – low risk and sensitivity. There is a waiver (LAT-XR-06769-01 CR) for thermal balance that would have fully verified this***

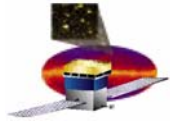

ACD PER

# Completed Verification Results Summary- Verification table status



8 June 2005

## ***ELECTRICAL SUMMARY***

- ◆ ***Pre-environmental functional and performance tests imminent.***
- ◆ ***Subsystem verification successfully completed.***
- ◆ ***The electronic chassis run completely independently and have been fully tested, as has each Tile Detector Assembly. They function the same on the assembled ACD; in fact the functional test is basically the same.***
- ◆ ***All channels have been light tested and tested with a source. So they have all been successfully exercised in their flight assembled configuration. Final performance measurements and any optimization occur during performance test.***
- ◆ ***The full subsystem verification and lack of any interdependency between channels minimizes and certainly limits issues that could arise during the about-to-occur fully assembled functional and performance tests.***
- ◆ ***The system level tests allow for optimization of settings, determining the ability to meet the efficiency requirement and exercising of the GASU side of the interface for multiple chassis.***

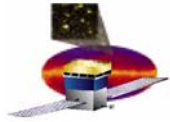

ACD PER

# Completed Verification Results Summary- Verification table status



8 June 2005

## ***ELECTRICAL SUMMARY***

### **◆ *Electrical requirements yet to be verified ;***

- Overall Efficiency – refer to earlier slides. Requires functional and performance test to be run and results to be inserted into final science simulation run***
- Light through-put performance of channels between the scintillating detectors and PMTs in their as-assembled condition. This is one of many inputs into the above efficiency requirement.***
- ICD interfaces have been verified at the chassis level, but the LAT side of the interface as represented by the EGSE GASU has only been fully tested so far with 2 chassis at one time.***
  - All eight chassis have been successfully run at once with the GASU during source testing but full performance testing when all eight chassis running at once is about to begin . (Testing may be temporarily limited by what we believe to be some remaining EGSE software issues. )***
  - All chassis work fully with GASU individually.***

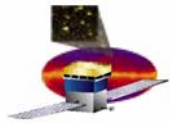

ACD PER

# Completed Verification Results Summary - Verification Status



8 June 2005

- Important verification sub-tables
  - Table of requirements to be re-verified at system level.
- These are all verified at chassis level, and there is no difference in function after assembled and in the basic functional test itself. Hard copy of complete table available

ReqID	LAT ACD Level IV Requirement	Verification Method	ACD System Verification Procedure	Planned Test
ACD4-25	5.1 Charged Particle Detection			
ACD4-26	The ACD shall produce both fast and logic (hitmap) VETO signals in response to PMT signals resulting from charged particles traversing the ACD tiles and ribbons.	Test	ACD Comprehensive Performance Test (CPT) (ACD-PROC-000270)	Efficiency test & TV
ACD4-27	5.2 Adjustable Threshold on VETO Detection of Charged Particles			
ACD4-28	The threshold for detecting charged particles shall be adjustable from 0.064 to 1.28 pC (0.1 to 2 MIP), with a step size of <0.032 pC (0.05 MIP).	Test	ACD Comprehensive Performance Test (CPT) (ACD-PROC-000270) Chassis Full Functional Test	Efficiency test & TV
ACD4-29	5.3 False VETO due to Electrical Noise			
ACD4-30	The total ACD false VETO trigger rate due to noise shall be less than 10 kHz (~46Hz per channel) at 0.096 pC (0.15 MIP) threshold (assuming 1 us VETO pulses).	Analysis Test Simulation	ACD Comprehensive Performance Test (CPT) (ACD-PROC-000270)	Efficiency test & TV
ACD4-31	5.4 High Threshold Detection			
ACD4-32	The ACD shall detect pulses due to highly ionizing particles (carbon nitrogen oxygen or heavier nuclei), which produce signals from 31.2 - 200 MIP (20 pC to 128 pC) with a goal of 1000 MIP (640 pC). The ACD is required to detect, via the High Level Discriminator (HLD), all signals above the High-Level threshold (nominally 25 MIP's); it is required to digitize (PHA) signals up to 200 MIP's (128 pC). The current design actually allows for digitization of signals up to 1000 MIP's (640 pC). Each ACD electronics board shall OR up to 18 HLD outputs (selected via command) to generate a single HLD_OR signal for transmission to the AEM.	Test Simulation	ACD Comprehensive Performance Test (CPT) (ACD-PROC-000270) up to ~200 MIP	Efficiency test & TV
ACD4-34	5.5 Adjustable High-Threshold			
ACD4-35	The High Level Threshold shall be adjustable for PMT signals from 12.8 to 40.96 pC (20 to 64 MIP) in steps of 0.64 pC (1 MIP) _20%. HOWEVER As of Oct 2003 the GAFE 5G and GAFE 7, one of which should be our flight chip, do not quite meet this requirement as stated. On those chips The High Level Discriminator is adjustable from 0 - 130 MIP in steps less than 1.6 MIP/step. This adjustability still allows us to meet all of our related requirements. So this is likely to be our flight performance. See related NCR	Test	ACD Comprehensive Performance Test (CPT) (ACD-PROC-000270)	Efficiency test & TV
ACD4-37	The ACD electronics shall accept from the GEM a	Test	ACD Comprehensive	

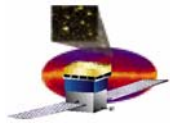

ACD PER

# Completed Verification Results Summary - Verification status



8 June 2005

- Important verification sub-tables
  - Table of requirements only verified at the subsystem level.
- These are not directly verifiable at system level, only indirectly. Hard copy of complete table available. All have been successfully verified.

The following table is a list of requirements that must be verified at a lower level of assembly than Electronic Chassis.

<i>No</i>	<i>DOORS ID</i>	<i>LAT-SS-00352 ID</i>	<i>Verified</i>	<i>ACD WOA</i>	<i>Rationale</i>
1	ACD4-39,40	5.7.1 Fast VETO Signal Latency	FREE Comprehensive Performance Test, ACD-PROC-000051, Section 11.4	ACD-WOA-00021 through ACD-WOA-00036	This test requires an oscilloscope on the GAFE output to make a direct measurement.
2	ACD4-41,42	5.7.2 Fast VETO Signal Width	FREE Comprehensive Performance Test, ACD-PROC-000051, Section 11.5	ACD-WOA-00021 through ACD-WOA-00036	This test requires an oscilloscope on the GAFE output to make a direct measurement.
3	ACD4-43,44	5.7.3 Fast VETO Retriggerring	GARC Comprehensive Performance Test, ACD-PROC-000051, Section 11.4, Discriminator Input Minimum Width Test	ACD-WOA-00021 through ACD-WOA-00036	This test requires an oscilloscope on the GAFE output to make a direct measurement.
4	ACD4-66,67	5.8.4 Pulse Height Measurement Latency	GLAST LAT ACD Interface Digital Timing Measurements, ACD-RPT-000274	Not applicable to this report.	This test requires an oscilloscope on the GAFE output to make a direct measurement.
5	ACD4-70,71	5.8.6 Differential Non-Linearity	FREE Comprehensive Performance Test, ACD-PROC-000051, Section 11.20	ACD-WOA-00021 through ACD-WOA-00036	This test requires the use of an external pulse generator.
6	ACD4-85,86	5.9.3 HVBS Limiting Output Current	HVBS Functional Test, ACD-PROC-000064, Sect. 4.5, Tables 3, 4, 5	ACD-WOA-00321 through ACD-WOA-00353	This test requires application of a non-flight load in the lab for verification.
7	ACD4-87,88	5.9.4 HVBS Output Voltage Adjustment	HVBS Functional Test, ACD-PROC-000064, Sect. 4.5, Tables 3, 4, 5	ACD-WOA-00321 through ACD-WOA-00353	Verification for this section requires both an oscilloscope and the application of a non-flight load.

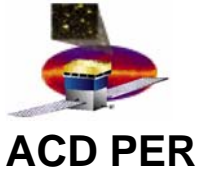

# Completed Verification Results Summary - *Comprehensive Performance Test*



8 June 2005

- ◆ A successful Comprehensive Performance Test of the fully integrated flight system is imminent .
- ◆ Document number is ACD-PROC-000270
- ◆ The test covers all aspects of the ACD functional areas such as
  - Voltages, currents, temperatures
  - Electronics performance (discriminators, PHA, timing)
  - Detector operation and performance
  - Commanding
- ◆ From previous table, almost all of our electrical requirements verification at system level is done by this procedure.
- ◆ As with chassis tests, remaining minor EGSE software issues may complicate analysis of results.

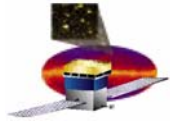

ACD PER

# Completed Verification Results - *Summary*



8 June 2005

- ◆ **All of our subsystem testing verification is complete and all major anomalies addressed.**
- ◆ **System level verification is almost complete with final functional and performance testing imminent. Completion of these tests will allow for final analysis and optimization of system settings and final channel performance inputs. Summary report will be sent out before commencing environmental tests.**

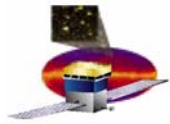

ACD PER

# ACD PER



8 June 2005

## *Environmental Test Flow*

*Craig Colthorp  
Integration and Test Manager, Code 568*

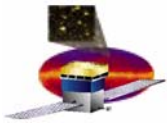

# Environmental Test Flow



ACD PER

8 June 2005

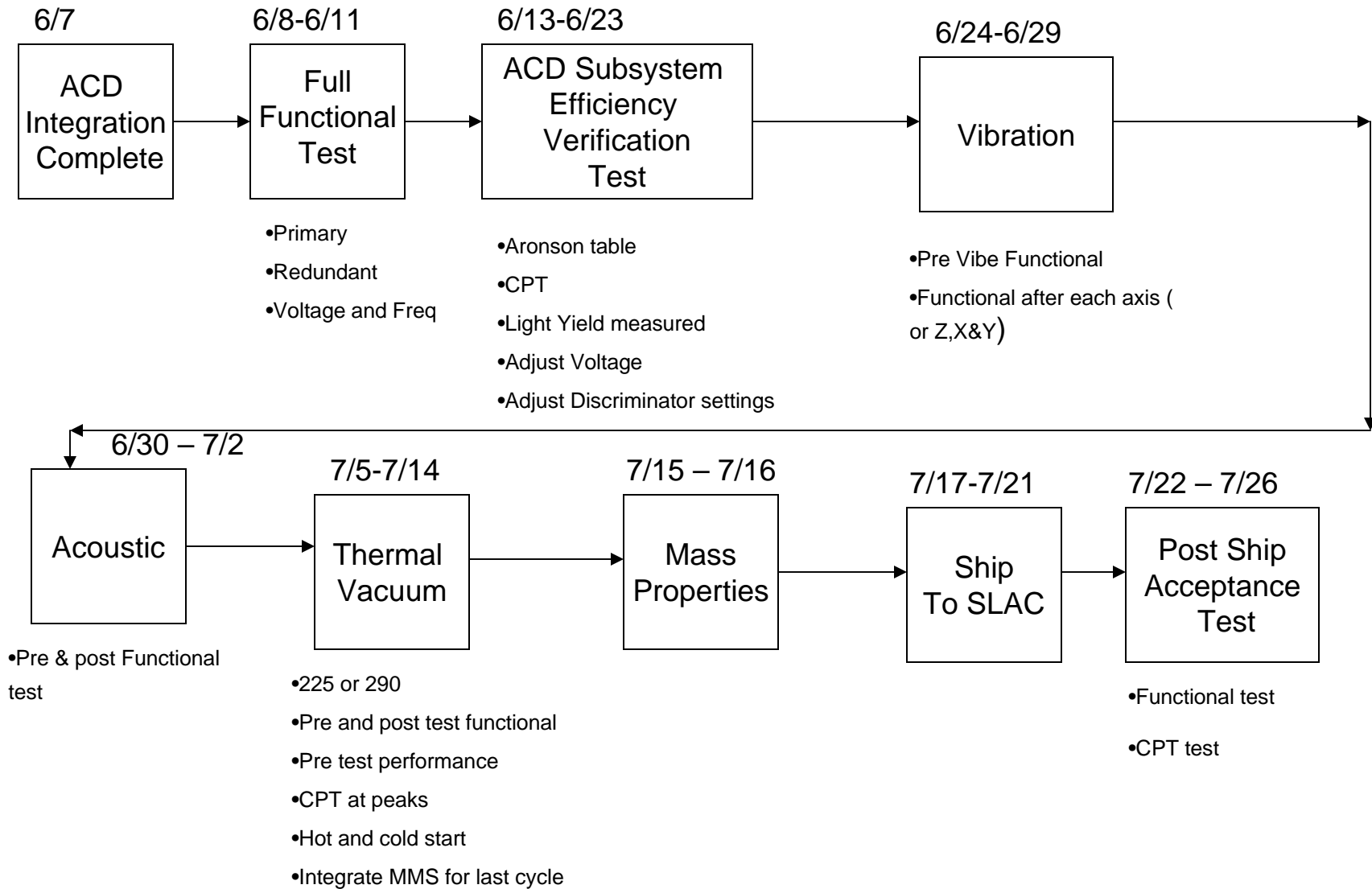

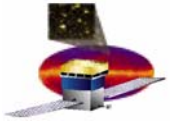

ACD PER

# Functional Testing



8 June 2005

## *Functional Test*

- ◆ ***AcdLongFunctional.py:***
  - Power on all chassis
  - Primary and Redundant sides
  - Put chassis in all modes
  - Verify all software and scripts function as intended

## *Monitor Test*

- ◆ Long data runs with PMTs at high voltage

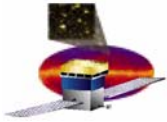

## *Comprehensive Performance Test*

### ◆ **ACD-PROC-000270**

- ***AcdLongFunctional.py***
  - *Power up*
  - *High Voltage*
  - *Read and Write Registers in GARC and GAFE*
  - *Commands and Data*
  - *Perform all functions*
  - *Execute all modes*
- ***Power Supply Rail Tests***
  - *Voltage Margin Test -3.2V to 3.6V and +24V to +29V*
- ***Multiple Clock Frequency Test***
  - *14MHz to 22MHz*
- ***Chassis Redundant Interface Test***
- ***In Rush Current Measurement***

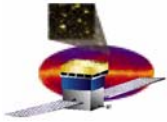

ACD PER

# Facilities



8 June 2005

- ◆ ***-Thermal Vacuum Facility***
  - ***Chamber 225***
    - *9' dia X 14' long*
    - *-310F to 302F*
- ◆ ***Vibration Facility***
  - ***GSFC's MB C-220 Exciters (4,082Kg)***
  - ***performed ACD TSA structural verification***
- ◆ ***Acoustics Facility***
  - ***GSFC's Acoustic Facility***
- ◆ ***Mass Properties***
  - ***GSFC's MPMF (4,536Kg)***

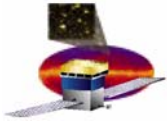

ACD PER

# Handling and Test Equipment



8 June 2005

## ◆ **-MGSE**

- *lift sling assembly BEA configuration GLAST p/n 2068104*
- *BEA HANDLING DOLLY p/n 2057516*
- *Dark Tent*
- *Purge Tent*
- *Helium Monitors (2)*
- *Aronson Table*
- *MMS Lift Sling*

## ◆ **EGSE**

- *Pentium PC running Windows XP (provided by 568)*
- *LATTE software provided by SLAC ( Python application software)*
- *GSE Software and Scripts developed by ACD Software team*
- *GASU #8 non-flight GSE Interface to ACD*
- *Instrumentation Monitor System (provided by 568)*

## ◆ **Other**

- *O<sub>2</sub> Monitor*
- *GN2 Purge*

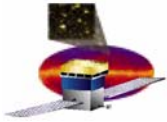

**ACD PER**

# Plans and Procedures



**8 June 2005**

## PLANS

- ◆ **GLAST LAT ACD Subsystem Verification Plan ACD-PLAN-000050** **4/5/2005**
- ◆ **ACD Configuration Management Plan ACD-PLAN-000107** **2/12/2003**
- ◆ **ACD Helium Monitor and Control Plan ACD-PLAN-000152** **11/2/2004**
- ◆ **ACD-On-Ground Science Performance Calibration and Monitoring** **4/6/2005**  
**ACD-PLAN-000332**
- ◆ **ACD Flight Instrument Protoflight Vibration Test Plan ACD-PLAN-000334** **In Review**
- ◆ **ACD Flight Instrument Protoflight Acoustic Test Plan ACD-PLAN-000335** **In Review**
- ◆ **ACD Flight Thermal Vacuum Test Plan ACD-PLAN-000347** **In Review**
- ◆ **ACD Integration and Test Plan ACD-PLAN-000350** **In Review**

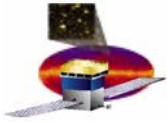

**ACD PER**

# Plans and Procedures



**8 June 2005**

## Procedures

- ◆ **ACD Mechanical Handling Procedure ACD-PROC-000195** **5/24/2004**
- ◆ **GLAST ACD Light Tight Test Procedure ACD-PROC-000252** **9/3/2004**
- ◆ **Comprehensive Performance Test Procedure ACD-PROC-000270** **In Review**
- ◆ **ACD Redline Procedure for Engineering Documentation ACD-PROC-000284** **12/17/2004**
- ◆ **GASU #8 Safe to Mate Procedure ACD-PROC-000333** **3/5/2005**
- ◆ **ACD GN2 Purge Structure Removal Procedure ACD-PROC-000336** **4/15/2005**
- ◆ **ACD-Monitor Operational Test Procedure ACD-PROC-000346** **5/13/2005**
- ◆ **Aronson Table Operation Procedure ACD-PROC-000349** **In Review**

## Work Instructions

- ◆ **Anti-Coincidence Detector (ACD) WOA Instructions ACD-WI-000118** **4/18/2003**

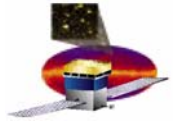

ACD PER

# Comprehensive Performance Test



8 June 2005

## ◆ **Status:**

- *Full Functional test of All Up ACD has not been performed*
- *Comprehensive Performance test is pending Full Functional*
- *Pending software modifications*
- *Expect software solutions during week of 6 Jun 2005*

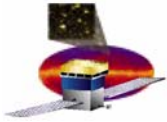

ACD PER

# EGSE Software



8 June 2005

- **The EGSE for the ACD was supplied by the LAT, using a LAT-developed software system called LATTE (LAT Test Executive).**
- **The ACD team writes test scripts in the Python language for this system.**
- **All ACD scripts have been written, although some debugging is still in progress. We have had difficulty with the ACD coincidence modes that are built into the system. The LAT team is actively supporting this testing effort.**
- **When we started running test scripts on the full ACD, we discovered EGSE system crashes that appear to be coming from Hippodraw, a SLAC graphics package. The author of Hippodraw was here Monday to help find the memory leaks that seem to be the issue. That work is still in progress.**
- **We need reliable Functional Test software and scripts working on the full ACD before starting environmental tests.**

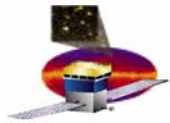

ACD PER

# Requirements Matrix



8 June 2005

## 5 Verification Table (excerpts)

Req ID	LAT ACD Level IV Requirement	Verification Method	ACD System Verification Procedure	Planned Test
ACD4-25	5.1 Charged Particle Detection			
ACD4-26	The ACD shall produce both fast and logic (hitmap) VETO signals in response to PMT signals resulting from charged particles traversing the ACD tiles and ribbons.	Test	ACD Comprehensive Performance Test (CPT) (ACD-PROC-000270)	Efficiency test & T/V
ACD4-27	5.2 Adjustable Threshold on VETO Detection of Charged Particles			
ACD4-28	The threshold for detecting charged particles shall be adjustable from 0.064 to 1.28 pC (0.1 to 2 MIP), with a step size of <0.032 pC (0.05 MIP).	Test	ACD Comprehensive Performance Test (CPT) (ACD-PROC-000270 Chassis Full Functional Test)	Efficiency test & T/V
ACD4-29	5.3 False VETO due to Electrical Noise			
ACD4-30	The total ACD false VETO trigger rate due to noise shall be less than 10 kHz (~46Hz per channel) at 0.096 pC (0.15 MIP) threshold (assuming 1 us VETO pulses).	Analysis Test Simulation	ACD Comprehensive Performance Test (CPT) (ACD-PROC-000270)	Efficiency test & T/V

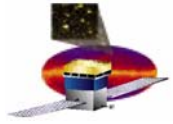

ACD PER

# ACD PER



8 June 2005

## *Safety*

*Andrew Kofeldt  
Systems Safety Engineer  
SRS Technologies/Code 302*

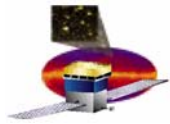

ACD PER

# Safety

## ACD I&T HAZARDS



8 June 2005

### – **Lifting Operations**

- *Lifting hardware has gone through all required analysis and certification and is inspected for possible damage before each use*
- *All lifting operations are supported by project safety and are conducted in accordance with a safety approved hazardous operations procedure*

### – **High Voltage**

- *High voltage circuits designed to operate at low current levels (80 $\mu$ A) –Startle Hazard*
- *Ground and contain high voltage sources.*
- *Post Warnings Signs In the Big Top Tent When High Voltage sources are powered and ensure power is removed when personnel work in the vicinity of high voltages.*

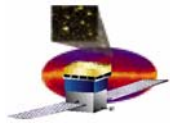

ACD PER

# Safety

## ACD I&T HAZARDS



8 June 2005

- **Radiation Source**
  - **ACD-PROC-000293 ACD Tile-to-Electronics-Channel Test Procedure**
  - **The ionizing radiation source used is Sr-090-064 with an output of 0.002 mCuries. The type of radiation is Beta particles**
  - **Radiation Safety Plan, use authorizations, source questionnaire, and personnel approval forms have been submitted to the Radiation Safety Office and have been approved**
  - **ACD Safety met with I&T complex Facilities operation manager and facilities safety to ensure delivery and use of source**
  - **Post warnings when Radiation Source is in use**
- **GN<sub>2</sub> Purge**
  - **Potential Asphyxiation Hazard**
  - **Purge Warning Posted**
  - **Use of O<sub>2</sub> Monitor**
  - **Procedure Developed to safely remove the purge structure ACD-Proc-000336**
    - **Project safety trains select project personnel on correct use of O<sub>2</sub> monitor and implementation of the removal procedure**
    - **Maintains a database of those who have completed the training**

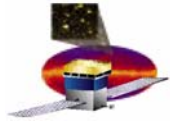

ACD PER

# Safety Documentation



8 June 2005

- ◆ ***Project Safety has developed an Operations Hazard Analysis***
  - *ACD-Plan-000348*
  - *Covers those potential Hazards associated with Environmental testing of the full ACD instrument*
    - *Root Causes, Hazard Controls, Verifications, and Close outs*
- ◆ ***I&T complex safety training was provided to ACD team project personnel through Paul Gibbons, Mantech Safety & Health Representative.***
- ◆ ***The ACD specific Emergency Action Plan was developed by project safety with inputs from project management, quality assurance and test conductors***
  - *Submitted to Code 250 (reviewed by code 500 and 302 safety personnel)*
  - *Included in the 7,10,15,29 complex safety Emergency Action Plan as an attachment available at <http://safety1st.gsfc.nasa.gov/eap.html#eap>*

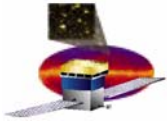

ACD PER

# Safety



8 June 2005

- ◆ ***All I&T operations adhere to governing , NASA and federal safety guidelines***
  - *NPR 8715.3 NASA Safety Manual*
  - *NASA-STD-8719.9 NASA Standard Lifting Standard*
  - *29 CFR 1910 Occupational Safety and Health Standards*
  - *540-PG-8715.1.1 Mechanical Systems Division Safety Manual, Vol I*
  - *540-PG-8715.1.2 Mechanical Systems Division Safety Manual, Vol II*
- ◆ ***All hazardous operations procedures and work order authorizations are reviewed and approved by project safety prior to use***

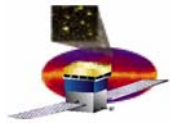

ACD PER

# ACD PER



8 June 2005

## *Risk Management*

*Tom Johnson*  
*Instrument Manager, Code 556*

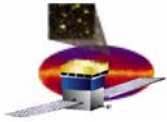

ACD PER

# Risk



8 June 2005

- ◆ *If failures occur the ACD is designed to fail 'gracefully'. Major failures result in incremental steps in performance. Other than a major micrometeoroid hit, it takes multiple failures to fail a detector channel. Complete detector channel failures leave holes in coverage.*
- ◆ *Micrometeoroid shield penetration is the only in orbit single point failure risk. ACD fails to meet the efficiency requirement with one tile destroyed by micrometeoroid penetration. The only other way to lose a entire detector channel is for multiple failures of other components.*
- ◆ *A GARC failure results in loss of up to 17 PMTs leaving 17 detector tiles operating on one PMT. The ACD marginally meets the efficiency requirement in this scenerio.*
- ◆ *Each Tile Detector Assembly and Ribbon Detector has fibers leading to two separate PMTs on separate electronic chassis. PMTs are powered by separate HVBSs.*
- ◆ *Each electronic chassis has redundant HVBSs.*
- ◆ *High Voltage for the PMTs can be adjusted in orbit to counteract PMT gain degradation over time.*



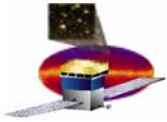

ACD PER

# Risk



8 June 2005

- ◆ *As part of the reliability/risk mitigation program, the following activities have been performed:*
  - *Failure Modes and Effect Analysis and Critical Items List ACD-RPT-000042 (LAT-TD-00913)*
  - *Limited-Life Item Analysis (LAT-TD-00523)*
  - *Reliability Assessments and Worse Case Analysis (ACD-RPT-000071)*
  - *Fault Tree (ACD-RPT-000072)*
  - *Parts Stress and De-rating Analysis*
  - *Continuous Risk Management Plan (LAT-MD-000067)*
  
- ◆ *Refer to Safety & Mission Assurance presentation for key results.*



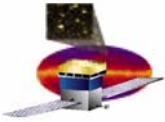

ACD PER

# ACD RISK ASSESSMENT



8 June 2005

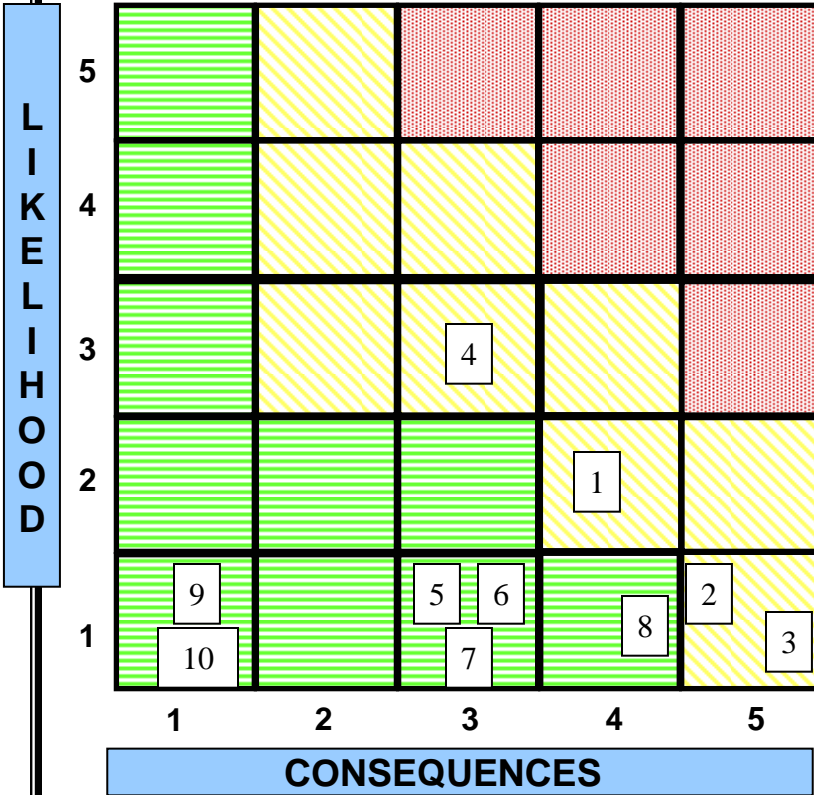

Criticality	Approach
High	M - Mitigate W - Watch
Med	A - Accept
Low	R - Research

Rank	Approach	Risk Title
1	M,R	Damage and/or light leak to Tile Detector Assembly
2	M,R	Electronics component failure (incl PMT subassembly)
3	M	EEE Part Failure
4	M	EGSE failure or malfunction
5	R,M	Facility problem.
6	M	Corona around high voltage during vacuum testing
7	M	Secondary structural failure during environmental testing
8	M	Damage to ACD during handling or test set up operations (including ESD)
9	M,A	ACD EMI/EMC Test Descope
10	R,A	ACD Thermal Balance test descope

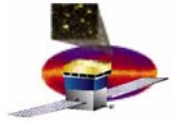

ACD PER

# ACD PER



8 June 2005

## *Systems Assurance Activities*

*Jim Lohr*

*Systems Assurance Manager, Code 303*

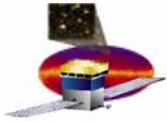

ACD PER

## Assurance Activities



8 June 2005

- ◆ ***Appropriate reliability analyses completed.***
  - ***Updated LAT/ACD Reliability Predictions and Failure Modes and Effects analyses, as appropriate, to include modifications relating to PMT glass fracture problems, fiber light yield losses, orbital debris flux modifications incorporated in ORDEM 2000, slight modification of the FREE board to prevent the GARC ASIC from being stuck at reset, due to the GARC look at me circuitry***
  - ***Supported failure investigations relating to the PMT glass fracture and PMT noise issues. Activities have included use of weibull analyses to assess the viability of “noisy” PMT screening tests to weed out early failures, glass failure mode consultation to identify fracture origin, and participation in external visual inspections of “as-received” PMTs***
  - ***Two single point failure components identified: MicroMeteoroid Shield (MMS) and GARC ASIC.***

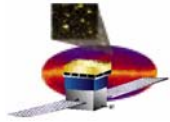

ACD PER

# Assurance Activities (Jim Lohr)



8 June 2005

## ◆ **EEE parts**

- *All DPA, PIND, screening and qualification testing has been completed for ACD with the exception of the GARC qualification testing.*
- *GARC test boards were not designed to withstand the temperature extremes parts were subjected to during qual testing: -30C to +85C and began producing false failures after 40 - 60 cycles.*
- *Consequently, we were never able to finish the 3-temp electrical testing on a sufficient number of life test samples to say that parts completed this testing successfully. There were no hard failures during life testing, but the final electricals could not be completed.*
- *New test boards will be built and GARC qual testing completed when and if ACD has manpower available.*

## ◆ **Materials related qualification tests are successfully completed.**

- *At a recent meeting of the Materials and Processes Control Board, all of the outstanding items were acceptable and, therefore, were closed. We are not expecting any new items or changes except in the event of a necessity dictated by some unforeseen problem.*

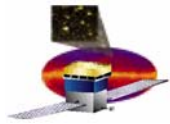

ACD PER

## ACD Problem /Failure Report Status



8 June 2005

As of June 7, 2005 a total of 312 Problem Reports (PR's) and 20 Problem Failure Reports (PFR's) have been opened

- ▶ 303 PR's have been closed
  
- ▶ 9 PR's open
  - ▶ 8 for EGSE related problems
  
  - ▶ 1 for a broken fiber on Tile Detector Assembly 230
  
- ▶ 18 PFR's have been closed
  
- ▶ 2 PFR's are open
  - ▶ PMT signal wire connector - Yellow
  
  - ▶ TDA gaps - Yellow

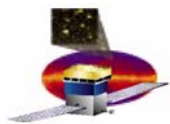

ACD PER

# Assurance Activities Open PR Status



8 June 2005

PR#	Problem Description	Date Entered	COMMENTS
ACD-2259-001	During the installation of Tile 230, one of the fibers in the CFC became broken at the bushing end.	6/7/2005	Fiber broke on last detector to be installed! The light output of the long tiles has been shown to exceed the requirement significantly. Therefore we can operate with one broken fiber with no loss of performance (this has always been part of our performance plan)
ACD-2261-002	AcdGafe Noise failed to get all counts on all garcs	5/9/2005	Common issue caused by test script. Script is being debugged.
ACD-2267-001	AcdGafe Noise aborted due to local ariable "newCounts" referenced before assignment.	5/11/2005	This PR as well as the other three 2267 series PR's were generated due to an EGSE crash. Software corrections are in process to resolve this issue.
ACD-2267-002	AcdHldCal aborted due to local variable "newCnoCounts" referenced befoe assignment.	5/11/2005	
ACD-2267-004	AcdGasuHwCtrsTci failed to get 100 counts on Garc 4 Channel 4, 5, 6, and 11 and Garc 5 Channels 6, 11, 12, and 13.....	5/11/2005	
ACD-2267-005	AcdHitMapPha several errors on multiple Garcs repeated: Time out waiting for ASC scalar event.....	5/11/2005	
ACD-02283-001	While running a full functona, in the test ACDhitmapdelay; received 2 painer errors, because histograms couldn't be plotted due to lack of data	5/24/2005	This PR as well as 2284-001 and -002 were generated due to an EGSE crash caused by a memory leak in the underlying EGSE software
ACD-02284-001	Acd Monitor cssript did not shut down	5/24/2005	
ACD-02284-002	During an Acd Monitor run, encountered the following errors: 1. Veto rate...	5/24/2005	

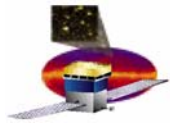

ACD PER

# Assurance Activities Open PFR Status



8 June 2005

PFR #	Problem Description	Date Entered	COMMENTS
ACD-019	PMT signal wire lepra-con connector failed during vibration.	5/31/2005	Only 1 out of nearly 250 connectors experienced a failure. The parts branch is performing a failure analysis, which will be completed by 6/10.
ACD-020	Tile Detector and Ribbon Detector gaps do not meet the requirements specified in drawing GE2054590.	6/6/2005	Variance is relatively small and should not impact performance. An updated science simulation is required to close this PFR. This will be closed out by the completion of the ACD performance test (prior to beginning environmental testing).

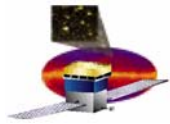

ACD PER

# ACD PER



8 June 2005

## *Programmatics*

*Tom Johnson  
Instrument Manager  
Code 556*

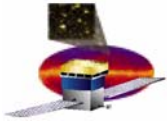

ACD PER

# ACD Organization Chart



8 June 2005

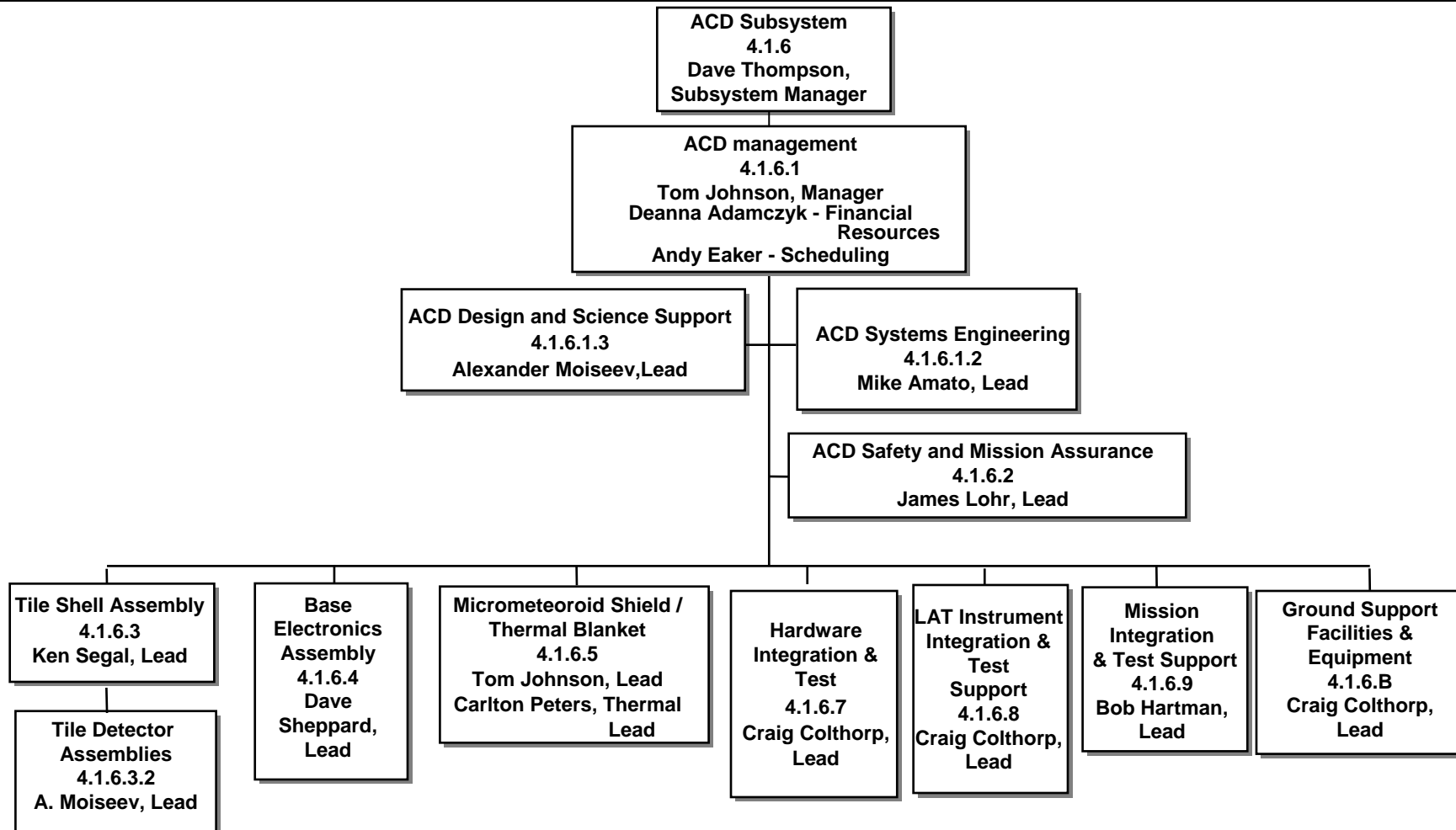

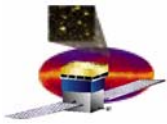

# GLAST LAT ACD SUMMARY SCHEDULE



ACD PER

8 June 2005

6/8/05

Task	2004			2005			
	2	3	4	1	2	3	4
Lat Instrument							
ACD Milestones					PER ◆	PSR ◆ RFI ◆ 7/26/05	
Tile Shell Assembly							
Tile Detector Assembly			Fit ◆◆ Spares				
Shell Assembly	Fit ◆						
Base Electronic Assembly							
Base Frame Assembly		Fit ◆					
High Voltage Bias Supply		Fit ◆					
Analog ASIC							
Digital ASIC							
Front End Elec. Cards			Fit ◆				
Photo Multiplier Tubes					(Fit PMT's) ◆		
Micrometeroid Sh./Th. Blkt						Fit ◆	
Mech Subsys (ready for I&T)	◆						
ACD I&T							
TSA Integration							
BEA Integration							
ACD Integration/Env. Test							
ACD Prep, Ship, RFI						Env. Testing ◆ ACD Ready for Integration ◆ (7/26/05)	
ACD to LAT Integration						Current LAT ND Date (10-21-05) ◆	

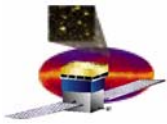

# TREND ANALYSES - COST



ACD PER

8 June 2005

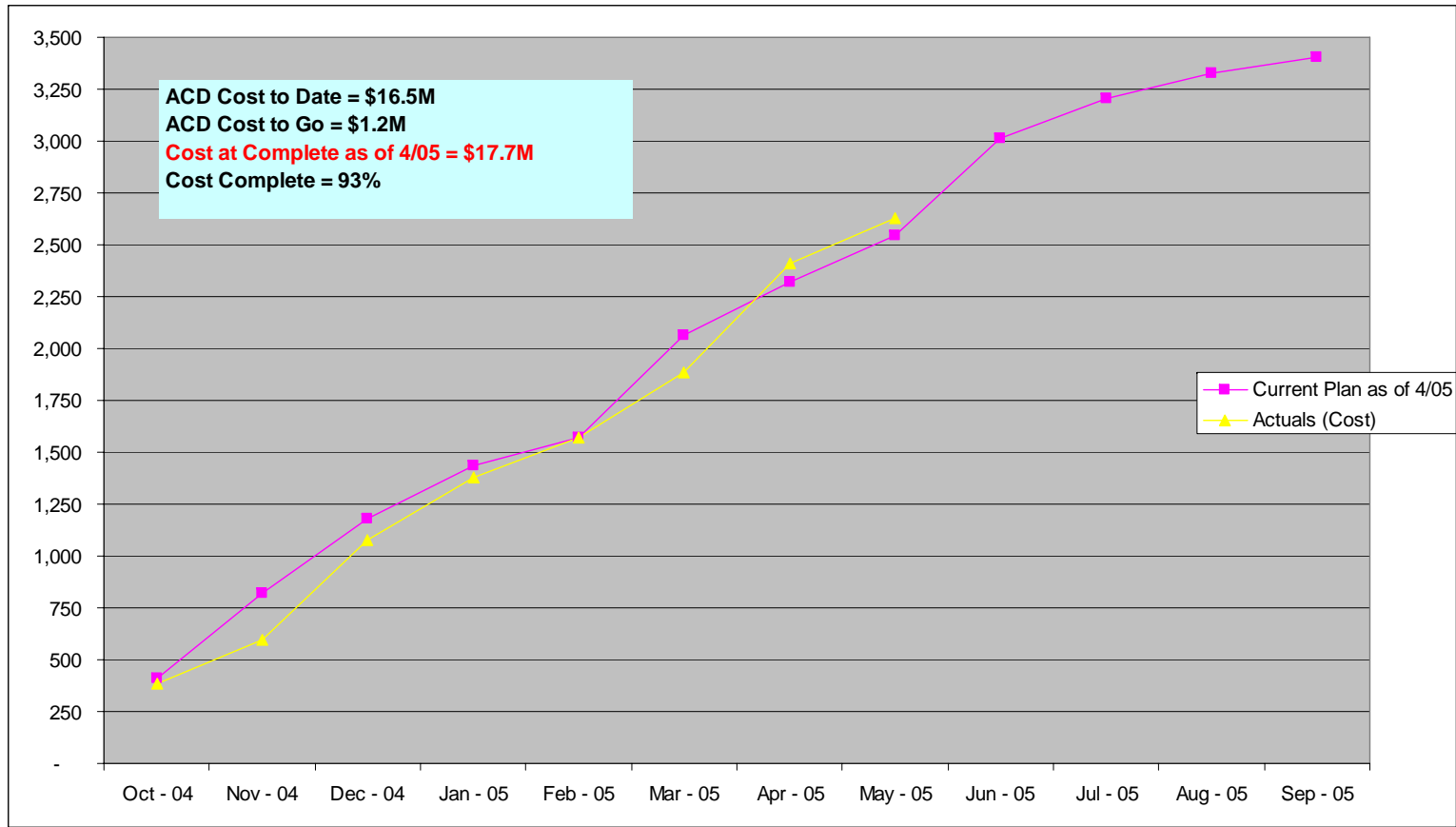

	Cum thru	FY05 Phasing Plan					FY05 Phasing Plan as of 4/05									Cost
	Sep - 04	Oct - 04	Nov - 04	Dec - 04	Jan - 05	Feb - 05	Mar - 05	Apr - 05	May - 05	Jun - 05	Jul - 05	Aug - 05	Sep - 05	FY06	FY07	At Complete
Current Plan as of 4/05	13,823	413	818	1,181	1,437	1,572	2,061	2,318	2,546	3,010	3,204	3,329	3,403	278	170	17,674
Actuals (Cost)	13,823	387	598	1,076	1,376	1,572	1,887	2,410	2,627							
Variance	-	(26)	(220)	(105)	(61)	-	(174)	92	81							

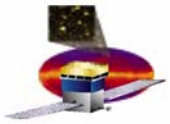

ACD PER

# Manpower Plan



8 June 2005

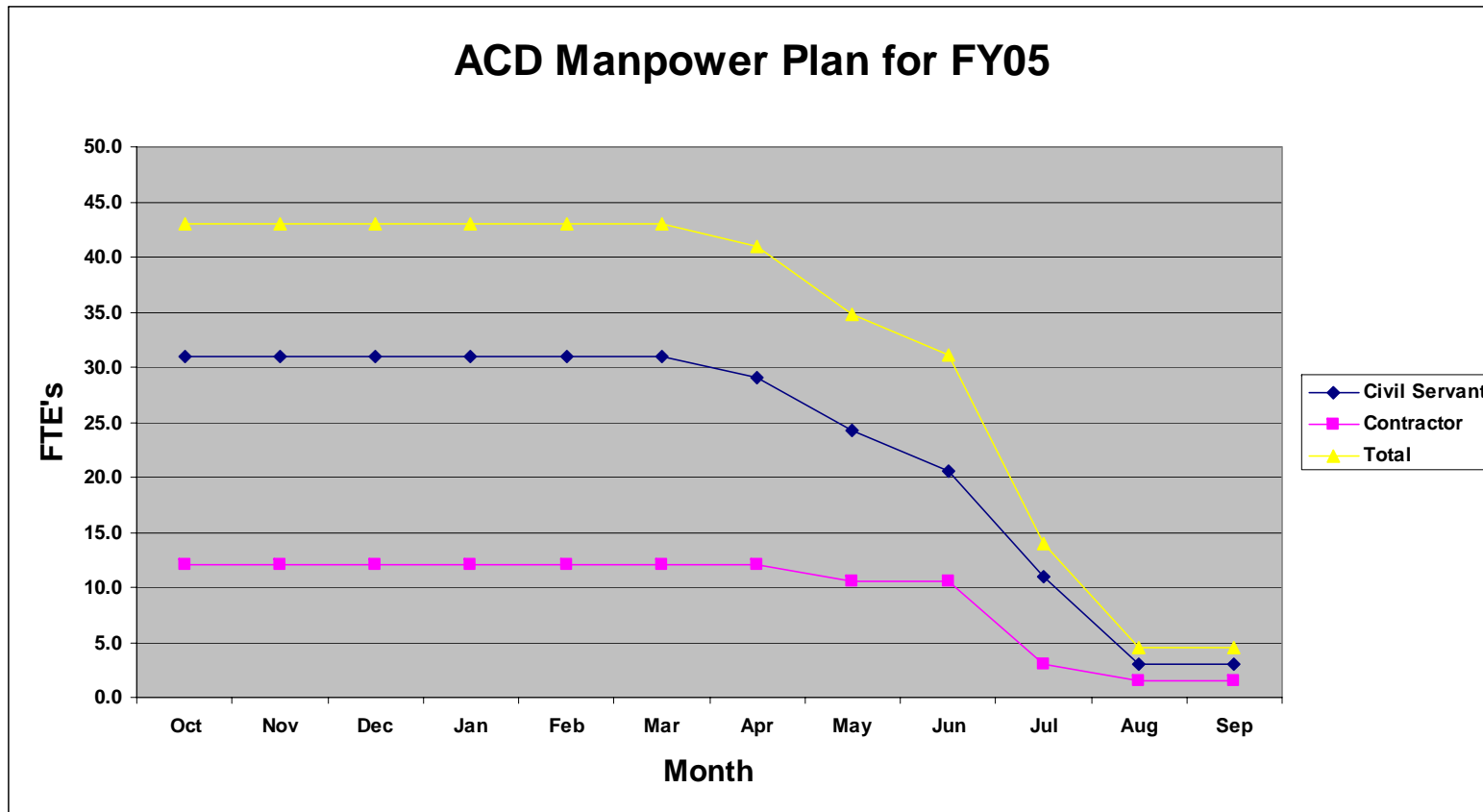

	FY05												FY05	FY06	FY07
	Oct	Nov	Dec	Jan	Feb	Mar	Apr	May	Jun	Jul	Aug	Sep	FTE		
<b>Civil Servant</b>	31.0	31.0	31.0	31.0	31.0	31.0	29.0	24.3	20.6	11.0	3.0	3.0	23.1	1	0.8
<b>Contractor</b>	12.0	12.0	12.0	12.0	12.0	12.0	12.0	10.5	10.5	3.0	1.5	1.5	9.3	1.13	0.8
<b>Total</b>	43.00	43.00	43.00	43.00	43.00	43.00	41.00	34.80	31.10	14.00	4.50	4.50	32.3	2.13	1.60

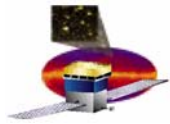

ACD PER

# Lien List - Cost



8 June 2005

LIEN #	Description	LAT Cost	Full Cost
2	MMS/TB Bakeout. Assumes 7 day B/O followed by chamber certification. Assumes no schedule impact. \$15.3K for facility (email from L. Tilwick on May 9) assuming facility cost sharing and \$4.5K for test set up / tear down.	19.8	23.8
3	TVAC in SES vs. Facility 225. One half of the cost difference provided (500 has already agreed to pick up 1/2 of the difference). Estimate provided by 549 was \$50-75K total.	0	35
4	Eighteen day schedule delay due to documentation, integration issues, technical issues, EGSE software, etc. Per day cost. = \$6.3K (\$18K full cost)	113.4	324
5	GASU #8 Vacuum Test - GASU #8 has not seen vacuum testing and will be vacuum tested with flight hardware. Failure could damage ACD flight hardware. Performing this test has an estimated 5 day schedule impact and this impact is figured into the cost estimate.	43.5	109
6	Additional stress analysis on MMS/TB attachment points to incorporate thermal loads imparted by MMS/TB	8.5	18.5
7	Increase manpower support on MMS to pull in delivery date.	35	35
8	Additional S&MA support to prepare for PER, close out PRs, and monitor floor activities	15	15
9	Three additional vibration tests on Electronic Chassis and final resolution and closeout of vibration frequency shift.	29	29
10	Alignment hardware for the Optical fiber to PMT connection.	8	8
11	Unplanned code 600 lab tax. \$32K in FY06 and \$24K in FY07	56	56
	TOTAL	328.2	653.3

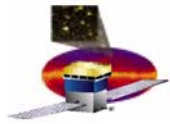

ACD PER

## Monthly Reviews



8 June 2005

- ◆ ***AETD Champion Team Review – Representatives from all applicable divisions within AETD review our status on the first Monday of every month. They also serve as our “champion” within their respective division and help us to resolve issues.***
- ◆ ***Goddard Monthly Status Review (MSR) – Issues, risks, schedule, milestones, cost, reserves, and accomplishments presented to the Goddard Program Management Council monthly.***
- ◆ ***GLAST/LAT Monthly Cost and Schedule Review – Technical issues, accomplishments, and cost and schedule variances and corrective actions presented to the LAT and GLAST Project Offices monthly***

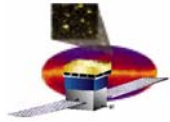

ACD PER

## Major Reviews – Past



8 June 2005

### ◆ **Past Reviews:**

- ***LAT Internal Review of the ACD – January, 1999***
- ***Pre-PDR/Baseline Review – February, 2001***
- ***LAT System Requirement Review (SRR)- May 2001***
- ***ACD Peer Review – July, 2001***
  - *62 RFA's – All closed out*
- ***LAT PDR/Baseline Review – January, 2002***
  - *12 RFA's – All closed out*
- ***LAT Internal Stanford Linear Accelerator Center Review - April, 2002***
- ***LAT Delta PDR/Baseline Review - July, 2002***
  - *3 RFA's – All closed out*
- ***ACD Critical Design Review – January 7 & 8, 2003***
  - *19 RFA's – All closed out*
- ***LAT Critical Design Review (CDR) – May 12 - 16 2003***
  - *2 RFA's – All closed out (both ASIC related)*
- ***DOE/NASA Independent Review – March, 2004***
- ***PMT Mounting Design Peer Review – August 30, 2004***
  - *18 RFA's – All closed out, zero PMT glass enclosures have failed using new mounting design*
- ***ISO Audit – November, 2004***
  - *2 Observations, no findings or RFA's*

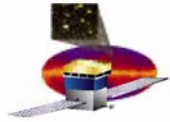

ACD PER

## Reviews – Future



8 June 2005

### ◆ *Future Reviews:*

- *ACD Pre-Environmental Review (PER) – June 8, 2005*
- *ACD Pre-Ship Review (PSR) – July 2005*
- *LAT Pre-Environmental Review (PER) – January 2006*
- *LAT Pre-ship Review (PSR) – May 2006*

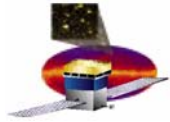

ACD PER

## SUMMARY



8 June 2005

- ◆ **All of our subsystem testing verification is complete and all major anomalies resolved.**
- ◆ **System level verification is almost complete with final functional and performance testing imminent. Completion of these tests will allow for final analysis and optimization of system settings and final channel performance inputs.**
- ◆ **The ACD is fully integrated and all detector channels have been verified to be operational and light tight**
- ◆ **The ACD Team has the necessary experience, skills and knowledge required to proceed with environmental testing.**
- ◆ **The ACD subsystem is fully prepared to proceed with environmental testing after successfully completing full functional testing and performance testing.**